

PERSISTENT ORGANIC POLLUTANTS

EDITOR STUART HARRAD

 WILEY



Persistent Organic Pollutants

Edited by

STUART HARRAD

*School of Geography, Earth and Environmental Sciences,
University of Birmingham, UK*



A John Wiley and Sons, Ltd, Publication

Persistent Organic Pollutants

Persistent Organic Pollutants

Edited by

STUART HARRAD

*School of Geography, Earth and Environmental Sciences,
University of Birmingham, UK*



A John Wiley and Sons, Ltd, Publication

This edition first published 2010
© 2010 Blackwell Publishing Ltd

Registered office

John Wiley & Sons Ltd, The Atrium, Southern Gate, Chichester, West Sussex, PO19 8SQ, United Kingdom
For details of our global editorial offices, for customer services and for information about how to apply for permission to reuse the copyright material in this book please see our website at www.wiley.com.

The right of the author to be identified as the author of this work has been asserted in accordance with the Copyright, Designs and Patents Act 1988.

All rights reserved. No part of this publication may be reproduced, stored in a retrieval system, or transmitted, in any form or by any means, electronic, mechanical, photocopying, recording or otherwise, except as permitted by the UK Copyright, Designs and Patents Act 1988, without the prior permission of the publisher.

Wiley also publishes its books in a variety of electronic formats. Some content that appears in print may not be available in electronic books.

Designations used by companies to distinguish their products are often claimed as trademarks. All brand names and product names used in this book are trade names, service marks, trademarks or registered trademarks of their respective owners. The publisher is not associated with any product or vendor mentioned in this book. This publication is designed to provide accurate and authoritative information in regard to the subject matter covered. It is sold on the understanding that the publisher is not engaged in rendering professional services. If professional advice or other expert assistance is required, the services of a competent professional should be sought.

The publisher and the author make no representations or warranties with respect to the accuracy or completeness of the contents of this work and specifically disclaim all warranties, including without limitation any implied warranties of fitness for a particular purpose. This work is sold with the understanding that the publisher is not engaged in rendering professional services. The advice and strategies contained herein may not be suitable for every situation. In view of ongoing research, equipment modifications, changes in governmental regulations, and the constant flow of information relating to the use of experimental reagents, equipment, and devices, the reader is urged to review and evaluate the information provided in the package insert or instructions for each chemical, piece of equipment, reagent, or device for, among other things, any changes in the instructions or indication of usage and for added warnings and precautions. The fact that an organization or Website is referred to in this work as a citation and/or a potential source of further information does not mean that the author or the publisher endorses the information the organization or Website may provide or recommendations it may make. Further, readers should be aware that Internet Websites listed in this work may have changed or disappeared between when this work was written and when it is read. No warranty may be created or extended by any promotional statements for this work. Neither the publisher nor the author shall be liable for any damages arising herefrom.

Copyright Acknowledgments

A number of articles in *Persistent Organic Pollutants* have been written by government employees in the United Kingdom. Please contact the publisher for information on the copyright status of such works, if required.

In general, Crown copyright material has been reproduced with the permission of the Controller of Her Majesty's Stationery Office.

Library of Congress Cataloging-in-Publication Data

Persistent organic pollutants / edited by Stuart Harrad.

p. cm.

Includes bibliographical references and index.
ISBN 978-1-4051-6930-1 (cloth : alk. paper) 1. Organohalogen compounds--Toxicology. 2. Organohalogen compounds--Environmental aspects. 3. Fireproofing agents--Toxicology. 4. Fireproofing agents--Environmental aspects. 5. Persistent pollutants--Bioaccumulation. 6. Persistent pollutants--Environmental aspects. I. Harrad, Stuart, 1962- RA1242.H35P47 2009
615.9'512--dc22

2009031403

A catalogue record for this book is available from the British Library.

Set in 10/12pt, Times Roman by Thomson Digital, Noida, India.

Printed and bound in Great Britain by CPI Antony Rowe Ltd, Chippenham, Wiltshire.

Contents

List of Contributors	xi
1 Beyond the Stockholm Convention: An Introduction to Current Issues and Future Challenges in POPs Research	1
<i>Stuart Harrad</i>	
References	4
2 Brominated Flame Retardants	5
<i>Robin J. Law</i>	
2.1 Introduction	5
2.2 Sources	7
2.3 Overview of Measurement Techniques	8
2.4 Physicochemical Properties and Their Influence on Environmental Fate and Behaviour	10
2.5 Overview of Toxicology	12
2.6 Environmental Levels – Present, Past and Future Temporal Trends	12
2.7 Human Exposure – Magnitude and Relative Significance of Pathways	15
2.8 Summary and Conclusions	18
Acknowledgements	18
References	18
3 Perfluoroalkyl Compounds	25
<i>Naomi L. Stock, Derek C. G. Muir and Scott Mabury</i>	
3.1 Introduction and Nomenclature	25
3.1.1 Polyfluorinated Sulfonamides (FSAs)	25
3.1.2 Fluorotelomer Alcohols (FTOHs)	25
3.1.3 Perfluoroalkylsulfonic Acids/Perfluoroalkylsulfonates (PFASs)	27
3.1.4 Perfluorocarboxylic Acids/Perfluorocarboxylates (PFCAs)	27
3.1.5 Fluorotelomer Carboxylic Acids/Fluorotelomer Carboxylates	27
3.1.6 Fluorotelomer Sulfonic Acids/Fluorotelomer Sulfonates	28
3.1.7 Fluorinated Polymers	28
3.1.8 Uses of PFCs	28
3.2 Manufacturing and Production	28
3.2.1 Electrochemical Fluorination	28
3.2.2 Telomerization	29
3.2.3 Production	30

3.3	Overview of Toxicology	31
3.3.1	Toxicology of PFSA and PFCAs	31
3.3.2	Toxicology of FTOHs and FSAs	32
3.3.3	Toxicology of FTCAs/FTUCAs	33
3.4	Physical Chemical Properties and Environmental Fate	33
3.4.1	The Influence of Fluorine	33
3.4.2	Water Solubility	34
3.4.3	Vapour Pressure	37
3.4.4	Henry's Law Constants	37
3.4.5	Sorption	38
3.4.6	Bioaccumulation	38
3.4.7	Other Partitioning Properties	39
3.4.8	Persistence of PFCs in the Environment	40
3.5	Overview of Measurement Techniques	40
3.5.1	Background Contamination	40
3.5.2	Sampling Techniques	41
3.5.3	Extraction and Clean-up Methods	41
3.5.4	Analysis via Liquid Chromatography–Tandem Mass Spectrometry	42
3.5.5	Analysis via Gas Chromatography–Mass Spectrometry	44
3.5.6	Analysis via Nuclear Magnetic Resonance	46
3.5.7	Total Fluorine Analysis	46
3.5.8	Analytical Challenges	46
3.6	Human Exposure	47
3.7	Sources of PFCs to the Environment	49
3.7.1	Sources of FSAs and FTOHs	49
3.7.2	Sources of PFSA and PFCAs	50
3.7.3	Sources of PFSA and PFCAs to the Arctic	50
3.8	Environmental Measurements	51
3.8.1	Atmosphere	51
3.8.2	Precipitation	52
3.8.3	Groundwater	53
3.8.4	Surface Waters	53
3.8.5	Sediments	55
3.8.6	Wildlife	56
3.8.7	Temporal Trends	57
	References	58
4	Chirality as an Environmental Forensics Tool	71
	<i>Charles S. Wong and Nicholas A. Warner</i>	
4.1	Introduction	71
4.2	Classes of Chiral Legacy and Persistent Organic Pollutants	73
4.2.1	Organochlorine Pesticides	73
4.2.2	PCBs and Their Metabolites	74

4.2.3	Pyrethroids	77
4.2.4	Polycyclic Musks	77
4.2.5	Brominated Flame Retardants	78
4.3	Measuring and Quantifying Enantiomer composition of POPs	79
4.3.1	Measurement of Chiral POPs	79
4.3.2	Metrics for Expressing Enantiomer Composition of POPs	81
4.4	Chirality to Characterize Environmental Biochemical Processes	82
4.4.1	Enantiomer-Specific Microbial Biotransformation of Chiral POPs	83
4.4.2	Enantiomer-Specific Transformation and Processing of Chiral POPs by Biota	93
4.5	Chirality to Quantify Rates of Biotransformation	109
4.6	Chirality as a Tool for Pollutant Source Apportionment	111
4.6.1	Air–Terrestrial Surface Exchange	111
4.6.2	Air–Water Exchange	115
4.7	Caveats in Using Chirality to Probe Biologically Mediated Environmental Processes	116
4.8	Conclusions	118
	Acknowledgements	119
	References	119
5	Persistent Organic Pollutants in the Developing World	137
	<i>Bondi Gevao, Henry Alegria, Foday M. Jaward and Mirza U. Beg</i>	
5.1	Introduction	137
5.2	Sources of POPs in Developing Countries	138
5.2.1	Summary of the Main POP Chemicals	139
5.2.2	Municipal Landfill Sites as Potential Sources of POPs to the Environment	145
5.2.3	Dumping of Toxic Wastes as a Source of POPs in Developing Countries	146
5.3	Levels of POPs in Developing Countries	147
5.3.1	Air	148
5.3.2	Butter	150
5.3.3	Sediments	151
5.3.4	Soils	151
5.3.5	Bivalves	154
5.3.6	Breast Milk	155
5.4	Problems Related to POPs in Developing Countries	159
5.4.1	Economic and Technical Problems	159
5.4.2	Legal Problems	160
5.4.3	Educational Problems	160
5.5	Conclusions	161
	References	161

6 Sources, Fate and Effects of Contaminant Emissions in Urban Areas	171
<i>Erin Hodge and Miriam Diamond</i>	
6.1 Introduction	171
6.2 Cities in the 21st Century	172
6.3 Urban Emission Sources	173
6.4 Urban Emissions and Urban–Rural Gradients	176
6.5 Chemical Mixtures in Urban Media	187
6.6 Fate in Urban Areas	188
6.7 Emissions and Environmental Degradation	191
6.8 Urban Form and Chemical Emissions	193
6.8.1 Transportation, Urban Sprawl and Emissions	193
6.8.2 Residential Density and Urban Heat Islands	195
6.8.3 Trends in Stormwater Management	195
6.9 Future Directions	196
6.9.1 Quantifying Rates of Emission	197
6.9.2 Influence of Urban Areas on Chemical Fate	197
6.9.3 Economic Activity, Urban Form and Chemical Emissions	197
6.9.4 From Dilution to Reduction	197
Acknowledgements	198
References	198
7 The Contamination of Indoor Environments with Persistent Organic Pollutants	209
<i>Stuart Harrad</i>	
7.1 Introduction	209
7.2 Methods of Sampling	210
7.2.1 Indoor Air	210
7.2.2 Indoor Dust	210
7.3 Sources and Levels of Indoor Contamination	212
7.3.1 General Observations	212
7.4 Relative Significance of Indoor Exposure	217
7.5 Uncertainties in Estimates of Exposure via Dust Ingestion and Indoor Air Inhalation	227
7.5.1 Dust Ingestion Rates	227
7.5.2 Air Sampling Artefacts	228
7.5.3 Biological Relevance of Samples: Within-room/building Spatial and Temporal Variability of Contamination	228
7.6 International Differences in Indoor Contamination	231
7.7 Concentrations in Different Microenvironment Categories	232
7.8 Influence of Indoor Contamination on Outdoor Contamination	234
7.9 Future Research Priorities	234
References	235

8 The Chemicals That Will Not Go Away: Implications for Human Exposure to Reservoirs of POPs	241
<i>Miriam Diamond and Stuart Harrad</i>	
8.1 Introduction	241
8.2 Conceptual Model of POPs	242
8.2.1 Case Study: PCBs	248
8.2.2 Case Study: Brominated Flame Retardants	254
8.3 Discussion	261
References	262
Index	271

Contributors

Henry Alegria, Department of Environmental and Occupational Health, College of Public Health, University of South Florida, Tampa, Florida, USA

Mirza U. Beg, Department of Environmental Science, Environment and Urban Development Division, Kuwait Institute for Scientific Research, Safat, Kuwait

Miriam Diamond, Department of Geography, University of Toronto, Toronto, Ontario, Canada

Bondi Gevao, Department of Environmental Science, Environment and Urban Development Division, Kuwait Institute for Scientific Research, Safat, Kuwait

Stuart Harrad, Division of Environmental Health and Risk Management, School of Geography, Earth, and Environmental Sciences, University of Birmingham, Birmingham, UK

Erin Hodge, Department of Geography, University of Toronto, Toronto, Ontario, Canada

Foday M. Jaward, Department of Environmental Science, Policy and Geography, University of South Florida, St Petersburg, Florida, USA

Robin J. Law, Centre for Environment, Fisheries, and Aquaculture Sciences (CEFAS), Lowestoft Laboratory, Lowestoft, Suffolk, UK

Scott Mabury, Department of Chemistry, University of Toronto, Toronto, Ontario, Canada

Derek C. G. Muir, Water Science and Technology Directorate, Environment Canada, Burlington, Ontario, Canada

Naomi L. Stock, Department of Chemistry, University of Toronto, Toronto, Ontario, Canada

Nicholas A. Warner, Department of Chemistry, University of Alberta, Edmonton, Canada

Charles S. Wong, Department of Chemistry, University of Alberta, Edmonton, Canada

1

Beyond the Stockholm Convention: An Introduction to Current Issues and Future Challenges in POPs Research

Stuart Harrad

*Division of Environmental Health and Risk Management, School of Geography,
Earth, and Environmental Sciences, University of Birmingham, UK*

The international significance of research into the sources, behaviour, fate, and effects of persistent organic pollutants (POPs) is exemplified by the Stockholm Convention for which the host organisation is the United Nations Environment Programme (UNEP). Following extensive negotiation, it was adopted on 22 May 2001, entered into force 90 days after the 50th party had ratified it on 17 May 2004, and by late 2008 there were over 180 participants (<http://chm.pops.int/>). The objective of the Convention is ‘to protect human health and the environment from persistent organic pollutants’ Among other things, it recognises the need for global action in recognition of the facts that POPs are toxic, resistant to degradation, and bioaccumulative. Furthermore, they are capable of global transport via air, water, and migratory species, and are deposited far from their place of release, where they accumulate in terrestrial and aquatic ecosystems.

As of 2008, there are 12 chemicals (or groups of chemicals) that are listed under the Convention. These 12 are listed in Table 1.1. The Convention also allows for the inclusion of additional chemicals under its scope. Parties to the Convention may propose such additions, and the case for their inclusion is considered by the POPs Review

Table 1.1 Chemicals currently listed and under consideration for listing as POPs under the Stockholm Convention

Currently listed	Under consideration
Aldrin	Chlordecone ^a
Chlordane	Endosulfan
DDT	Hexabromobiphenyl ^a
Dieldrin	Hexabromocyclododecane
Endrin	α -Hexachlorocyclohexane
Heptachlor	β -Hexachlorocyclohexane
Hexachlorobenzene	γ -Hexachlorocyclohexane (Lindane) ^a
Mirex	Octabromodiphenyl ether
Polychlorinated biphenyls	Pentabromodiphenyl ether ^a
Polychlorinated dibenzo- <i>p</i> -dioxins	Pentachlorobenzene
Polychlorinated dibenzofurans	Perfluorooctane sulfonate ^a
Toxaphene	Short chain chlorinated paraffins

^aAlready recommended by the POPs Review Committee (POPRC) for listing under the Convention.

Committee (POPRC). For a chemical to be included in the Convention, it must display the following:

Persistence,
 Bioaccumulation,
 Potential for long-range environmental transport, and
 Adverse effects.

Full details of the evidence required for these criteria to be fulfilled are included under Annex A of the text of the Stockholm Convention. As of late 2008, a further 12 chemicals were under consideration by POPRC for inclusion under the Convention. These are also listed in Table 1.1.

Inspection of Table 1.1 reveals that while all those listed under the original test of the Convention are organochlorines, those under consideration for inclusion include one organofluorine and a number of organobromine chemicals. Hence while this book addresses, to at least some degree, most or all of the chemicals listed in Table 1.1, it focuses particularly on polychlorinated biphenyls (PCBs), hexabromocyclododecane (HBCD), perfluorinated chemicals (PFCs), and polybrominated diphenyl ethers (PBDEs). These are selected on the basis that they either:

- (a) represent an example of a currently listed POP that, despite significant efforts, remains of concern (i.e. PCBs), or
- (b) are under consideration by POPRC *and* have been the subject of an explosion in scientific interest in the last decade (HBCD, PFCs, and PBDEs).

Both HBCD and PBDEs are examples of brominated flame retardants (BFRs). The recent growth in the number of scientific papers addressing the environmental presence and impacts of such chemicals has been quite phenomenal. In a similar vein, there has been a dramatic rise in concerns related to the environmental presence and impacts of perfluorinated chemicals (PFCs). Chapters 2 and 3 thus address current knowledge and research

priorities related to these groups of contaminants – often referred to as ‘new’ or ‘emerging’ POPs.

Making progress with understanding the environmental processes and pathways by which POPs transfer from their sources into wildlife and humans requires the application of sophisticated measurement techniques. One such area that has seen particular recent growth is the exploitation of the chiral properties possessed by several POPs. Chapter 4 describes how recent research in this field has provided new insights into the environmental sources and cycling of POPs.

Given the global nature of the Convention, it recognises that the nature of the problems faced by developing countries, and their capacity to tackle these problems, are often distinct from those associated with the developed world. For example, while in regions such as North America and western Europe concerns are expressed about human exposure arising from indoor contamination with BFRs emitted from items like consumer electronics, developing world concerns about BFRs are more likely to be related to issues such as emissions arising from the uncontrolled dumping and burning of BFR-containing waste, often shipped from the developed world (Athanasidou *et al.*, 2008). The vast majority of what is known about POPs concerns the developed world, despite evidence that substantial problems exist in developing countries. It is for this reason that Chapter 5 of this book addresses the situation regarding POP contamination in such regions.

The primarily agricultural applications of some organochlorine pesticides, combined with the bioaccumulative potential and persistence of POPs that confers their well-characterised capacity to accumulate in food chains, can lead to a perception that the problems associated with POPs are largely to be found in rural, food-producing regions. In reality the urban environment plays a pivotal role in driving the emissions of POPs. Coupled with the ever-increasing rate of urbanisation, the specific physical characteristics of our cities are also of interest as they interact with POPs in a very different fashion to rural regions. Chapter 6 therefore examines urban issues related to POPs.

Traditionally, because measurements of human exposure to POPs via the diet exceeded considerably that received via inhalation of outdoor air and ingestion of water, human exposure via pathways other than diet have in the past been largely ignored. Recently, however, researchers have realised that in instances where POPs have found appreciable indoor applications, the resultant elevated indoor contamination, coupled with the high proportion of time spent indoors (typically 90% or more in many countries) renders pathways of exposure other than diet of importance. In particular, the past widespread deployment of PCBs in, for example, building sealants has led to concentrations in indoor air that considerably exceed those present outdoors, to the extent that inhalation of such air is an appreciable exposure pathway (Currado and Harrad, 1998). More recently, attention has been drawn to the potential of incidental ingestion of indoor dust as a vector for exposure to brominated flame retardants and perfluorinated stain-proofing chemicals that enter dust as a result of their widespread deployment in electronic goods and fabrics, etc. (Abdallah, Harrad, and Covaci, 2008; Jones-Otazo *et al.*, 2005; Shoeb *et al.*, 2005). This is of special concern for infants and toddlers owing to their lower body weights and likely high dust ingestion rates compared to adults. Chapter 7 therefore examines the state of knowledge regarding the sources, levels, and human exposure implications of indoor contamination with POPs.

Finally, there is a perception that banning manufacture and new use of a POP will suffice as a control measure. While such action will have a short-term beneficial impact, further reductions in contamination are likely to be limited for as long as goods and materials produced before the ban remain in use or are otherwise not destroyed. Where the 'turnover' or replacement time of such items is long, they will represent an ongoing emission source for some time after implementation of the ban on manufacture. One example is the existence of substantial stockpiles of unused organochlorine pesticides in developing countries. Another scenario more pertinent to the developed world is the burden of POPs associated with goods and materials contained within the built environment. In both such instances, the remaining burden of these chemicals requires urgent action if their release into the environment is to be prevented. The final chapter of this book describes how indoor contamination can migrate outdoors, enter the food chain and thus 'buffer' dietary exposure. Potentially more serious, however, is the potential for environmental contamination and concomitant human exposure that exists if emissions arising from the end-of-life disposal of POPs-treated goods and materials are incorrectly managed. Chapter 8 thus calls for a radical reevaluation of the way in which we manage the life cycle of goods and materials treated with POPs, so that environmental contamination at the end of their life is minimized.

In the four years since the Stockholm Convention came into force, there has been substantial progress in our understanding of the environmental sources, behaviour, and impacts of POPs. At the same time, new issues and challenges have emerged – not least the identification of 'new' POPs like BFRs and PFCs – alongside the development of new thinking and strategies to tackle the problems. This book is intended to go some way towards identifying and describing these. In the author's view, POPs are likely to continue to provide extremely fertile research ground for the foreseeable future. Given the number of new chemicals under consideration for listing under the Stockholm Convention – a trend that is unlikely to abate anytime soon – it is imperative that scientists and policy-makers learn as much as possible from current knowledge related to the sources, fate, behaviour, and effects of those POPs listed currently and which have already been the subject of study for several decades. Such action is essential to prevent us repeating the mistakes of the past.

References

- Abdallah, M. A., Harrad, S., Covaci, A. (2008) Hexabromocyclododecanes and tetrabromobisphenol-A in indoor air and dust in Birmingham, UK: implications for human exposure. *Environ. Sci. Technol.*, **42**: 6855–6861.
- Athanasiadou, M., Cuadra, S. N., Marsh, G., Bergman, Å., Jakobsson, K. (2008) Polybrominated diphenyl ethers (PBDEs) and bioaccumulative hydroxylated PBDE metabolites in young humans from Managua, Nicaragua. *Environ. Health Perspect.*, **116**: 400–408.
- Currado, G. M., Harrad, S. (1998) A comparison of polychlorinated biphenyl concentrations in indoor and outdoor air and the potential significance of inhalation as a human exposure pathway. *Environ. Sci. Technol.*, **32**: 3043–3047.
- Jones-Otazo, H. A., Clarke, J. P., Diamond, M. L., Archbold, J. A., Ferguson, G., Harner, T., Richardson, G. M., Ryan, J. J., Wilford, B. (2005) Is house dust the missing exposure pathway for PBDEs? An analysis of the urban fate and human exposure to PBDEs. *Environ. Sci. Technol.*, **39**: 5121–5130.
- Shoeib, M., Harner, T., Wilford, B. H., Jones, K. C., Zhu, J. (2005) Perfluorinated sulfonamides in indoor and outdoor air and indoor dust: occurrence, partitioning, and human exposure. *Environ. Sci. Technol.*, **39**: 6599–6606.

2

Brominated Flame Retardants

Robin J. Law

*Centre for Environment, Fisheries, and Aquaculture Sciences (CEFAS), Lowestoft Laboratory,
Lowestoft, Suffolk, UK*

2.1 Introduction

Brominated flame retardants (BFRs) are a diverse group of chemicals that are used to protect the public from accidental fires by reducing the flammability of combustible materials such as plastics and synthetic polymers (Watanabe and Sakai, 2003). The most widely used to date are the polybrominated diphenyl ethers (PBDEs), hexabromocyclododecane (HBCD) and tetrabromobisphenol-A (TBBP-A) (see Figure 2.1), although many other compounds have been developed (Birnbaum and Staskal, 2004). Depending on the product being produced and the flame retardant compound used, the flame retardant may be incorporated either additively or reactively. In the former case the flame retardant is simply mixed with the product at the production stage, in the latter the flame retardant is chemically bound. If chemically incorporated, the flame retardant is less likely to leach from the product during its lifetime. Up-to-date information on the levels of production of brominated flame retardants are not available. The Bromine Science and Environmental Forum estimated the total market demand for the major commercial BFRs by region in 2001 (Table 2.1). Evidence of the environmental persistence of a number of BFRs has led to risk assessments and risk reduction measures in a number of legislative areas, as well as voluntary emissions control measures by industry. Subsequently, production and use of the penta-mix and octa-mix PBDE formulations has ceased in the European Union following regulation in 2004, and the deca-mix product was banned in 2008 following a ruling by the European Court of Justice. Risk assessments for HBCD and TBBP-A have been completed within the EU (European Commission, 2006, 2008; Eisenreich, Munn and Pakalin, 2007; Spiegelstein, 2007). The reports of these risk assessments can be accessed on the website

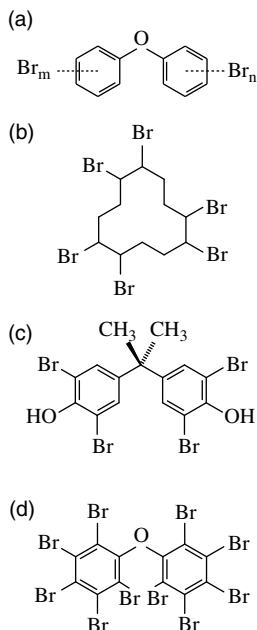

Figure 2.1 Chemical structures of major flame retardant compounds: (a) polybrominated diphenyl ethers, (b) hexabromocyclododecane, (c) tetrabromobisphenol-A, (d) decabromodiphenyl ether (BDE209)

of the European Chemicals Bureau at http://ecb.jrc.ec.europa.eu/home.php?CONTENU=/DOCUMENTS/Existing-Chemicals/RISK_ASSESSMENT/REPORT/.

In the USA, penta- and octa-PBDE formulations were also voluntarily phased out in 2004. In Japan, the consumption of PBDEs is declining due to effective regulation and voluntary restriction, while that of HBCD is increasing (Isobe *et al.*, 2007). TBBP-A, the most widely used BFR, is used primarily as a reactive flame retardant in printed circuit

Table 2.1 The usage (tonnes) of selected brominated flame retardants in different areas of the world in 2001

Product	Americas	Europe	Asia	Rest of the world	Total	% of total world usage
TBBP-A	18 000	11 600	89 400	600	119 700	59
HBCD	2800	9500	3900	500	16 700	8
Deca-mix PBDE formulation	24 500	7600	23 000	1050	56 100	27
Octa-mix PBDE formulation	1500	610	1500	180	3790	2
Penta-mix PBDE formulation	7100	150	150	100	7500	4
Total	53 900	29 460	117 950	2430	203 790	

boards (Birnbaum and Staskal, 2004), and so is most likely to be observed close to locations at which TBBP-A is produced and used. These should mostly be in Asia, which currently has no controls in place on BFRs (BSEF, 2007; Law *et al.*, 2008b).

2.2 Sources

In general, POPs are used in industrial or agricultural applications, and exposure depends largely on proximity to these or to point-source discharges. For BFRs, the situation is different, other than close to sites of production and use, e.g. textile manufacture. Analysis of sewage sludges in a number of countries has demonstrated that there is little correlation between BFR levels and the degree of industrial discharge to wastewater treatment plants. The major source of background levels in sludge is from diffuse leaching of these compounds into wastewater streams from users, households and industries generally (Law *et al.*, 2006a). Study of BFR concentrations in atmospheric samples has shown that urban/suburban areas exhibit higher concentrations than semi-rural/rural areas (Harrad and Hunter, 2004). BFRs are incorporated into many household products and house building materials, and indoor air from buildings is acting as a source to the outdoor environment. Similarly, household dust can be contaminated to high concentrations with BFRs, and this forms a very significant exposure route, particularly for toddlers and small children (Ibarra *et al.*, 2007; Wilford *et al.*, 2005). Another area that is receiving considerable attention at present is the shredding and recycling of electronic waste (e-waste). In studies using Italian ryegrass as a passive sampler, Wanner *et al.* (2007) showed summed BDE concentrations up to 450 µg/kg dry weight around shredder plants in Bavaria. The highest concentrations were observed in the vicinity of the oldest plant, and congener patterns were linked to the material being processed, either containing the deca-PBDE or the penta- and octa-PBDE products.

Occupational exposure of workers at plants using BFRs has been assessed for both PBDEs and HBCD (e.g. see Sjödin *et al.*, 2001). In the most recent study, Thomsen *et al.* (2007b) studied HBCD in workers at a factory manufacturing expanded polystyrene to which HBCD is added during production. As could be expected, workers exhibit serum levels of HBCD higher than those observed in the general population, as for PBDEs. The congener pattern for HBCD in the airborne dusts to which the workers were exposed closely resembled that of the technical HBCD mixture used at the factory (ca. 80% γ -HBCD), in contrast to the usual distribution in humans and wildlife in which α -HBCD dominates. Of particular concern in this respect is the situation in the Far East. In addition to areas such as the Pearl River Delta in China having large numbers of electronics manufacturing and assembling plants, e-waste is being imported into China at a current rate of 35 000 tonnes per annum. Guiyu in China has become an intensive e-waste recycling site, and incomplete combustion of e-waste and the dumping of processed materials are sources of various toxic chemicals, including PBDEs. This is leading to increasing pollution of rivers and coastal waters, and contamination of local fish and sediments (Guan *et al.*, 2007; Luo, Cai and Wong, 2007; Wong *et al.*, 2007). BDE209 is the dominant PBDE congener in both the serum of e-waste dismantling workers (Qu *et al.*, 2007) and sediments in the area. The PBDE market in Asia in 2001 accounted for 37% of world demand: 23 000 tonnes of deca-PBDE, 1500 tonnes of octa-PBDE and 150 tonnes of penta-PBDE (Guan *et al.*, 2007).

2.3 Overview of Measurement Techniques

This area has most recently been reviewed by Covaci *et al.* (2007a). Matrices commonly analysed include air, dust, soils, sediments, sewage sludges and a wide variety of biota samples, both terrestrial and aquatic (Law *et al.*, 2008b). BFRs have not been widely determined in water as these compounds are hydrophobic with high $\log K_{ow}$ values, and will tend to bind to soils and sediments in preference to remaining in the water column. Covaci *et al.* (2007a) have exhaustively covered extraction and clean-up techniques and it is not proposed to repeat this material here – readers are referred to their review. It is, however, worthwhile including some discussion on techniques for the determination of BFRs, certified reference materials, quality control and the current performance within intercomparison exercises.

Mass spectrometry (MS) is almost universally applied within BFR analysis, although the type of instrumentation applied and the mode of ionisation employed vary (Figure 2.2). For the BDEs, GC-MS is routinely applied, with both high- and low-resolution MS instruments in use. The ionisation mode used is either EIMS (electron impact MS mode) or ECNIMS (electron capture negative ion MS mode), in the latter case generally monitoring the bromine ions at 79 and 81 daltons. Essentially, GC-ECNIMS is functioning as a selective detector for organobromine compounds in general. For congeners in the tri- to hepta-BDE range (those deriving from the penta-mix PBDE formulation), the analysis and determination are relatively straightforward, and intercomparison exercises have shown a level of intercomparability increasing with time and experience. In the octa- to deca-bromo BDE congener range, which includes BDE183 (often considered a marker for the octa-mix formulation), BDE209 (the main congener found in the deca-mix product) and the intermediate octa- and nona-bromo congeners that could be generated by debromination of BDE209 (an issue at the heart of the debate over the environmental risk posed by the deca-mix), analysis is less simple. Taking BDE209 as the most extreme example, with a $\log K_{ow} \sim 9$, due to its thermal instability, photosensitivity and its ability to bind strongly to surfaces, including laboratory glassware, determination of this congener is problematic. Achieving clean blanks and avoiding cross-contamination due to incompletely cleaned glassware are key, as is optimising the GC conditions. Lack of thermal stability can be circumvented by the use of short GC columns. Photosensitivity can be countered by using amber glassware or wrapping clear glassware in aluminium foil and using UV light filters on windows and fume cupboard fronts. ^{13}C -labelled BDE congeners are available for use as internal standards, and this is particularly important for BDE209. Protocols suitable for the determination of BDE209 have been developed (de Boer *et al.*, 2001) and need to be applied stringently if good interlaboratory agreement is to be achieved. This should not cause analysis of BDE209 to be neglected, as it is a high-production volume compound and widely distributed in the environment, but the best available methods should be used in all studies, with an appropriate level of quality control. Recently, a range of fluorinated BDE congeners have been produced as alternatives to ^{13}C -labelled congeners. Another technique that has been applied to the analysis of BDEs is comprehensive two-dimensional gas chromatography (GC \times GC) (Korytár *et al.*, 2005, 2006) in order to try to solve problems of co-elution of some BDE congeners with other brominated compounds, which occurs on a single GC column. Even with the most effective combination of GC columns, the number of co-elutions was reduced but not eliminated entirely.

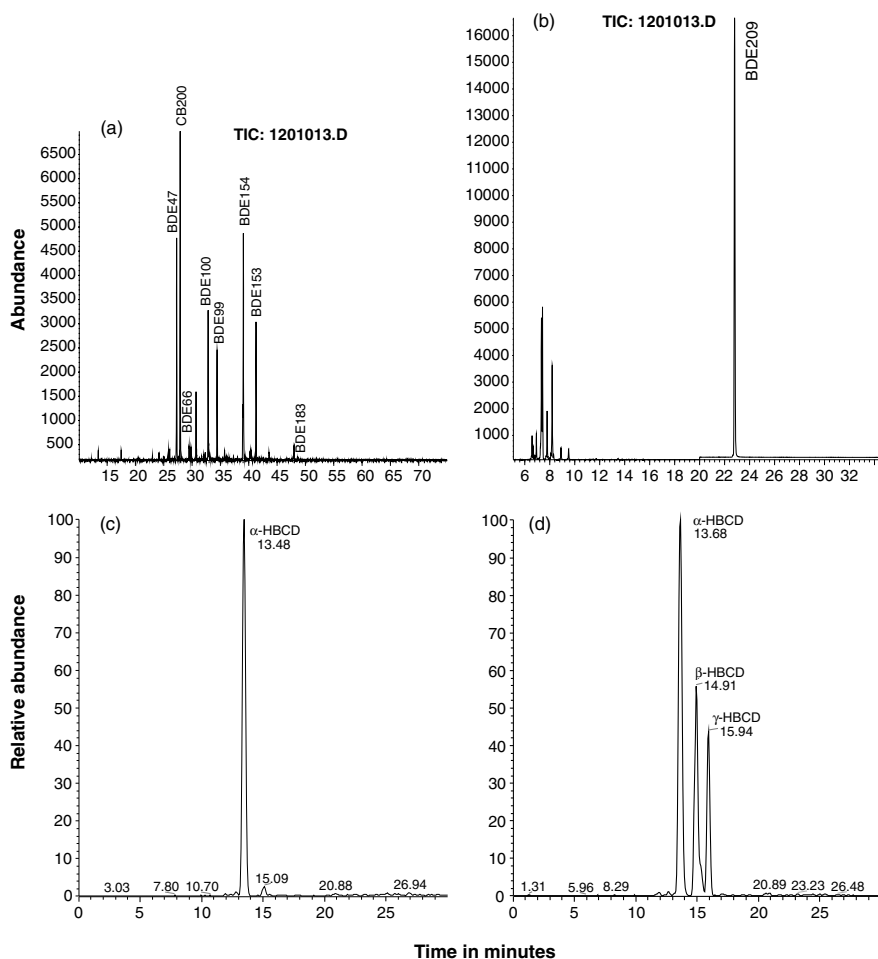

Figure 2.2 Chromatograms of major BFRs: (a) tri- to octa-BDE congeners, (b) BDE209 (decabromodiphenyl ether), both analysed by gas chromatography–electron capture negative ion mass spectrometry using a column of 50 m length in (a) and of 15 m length in (b), where in (a) CB200 is the internal standard; (c and d) HBCD analysed on a diastereoisomer-specific basis by LC-MS. TBBP-A can be analysed in the same analytical run, but is seldom detected in UK samples. Samples analysed were: (a) blubber from a harbour porpoise SW2003/186 stranded at Hell's Mouth, Gwynedd, 26 March 2003, (b) dredged sediment from Billingham Reach, River Tees, 29 November 2005, (c) blubber from a harbour porpoise SW2005/34B stranded at Dunoon, Strathclyde, 19 February 2005, (d) blubber from a harbour porpoise SW2006/41 stranded at Putney Bridge, London, 21 January 2006

HBCD has also been determined using GC-MS, but this approach cannot be recommended. This is because HBCD degrades on passage through the GC column due to its thermal instability, meaning that it is not possible to determine the three diastereoisomers (α -, β - and γ -HBCD) using this technique, and that even for the determination of total HBCD a broad peak is observed. The determination of HBCD on an individual

diastereoisomer basis by LC-MS is fully established (Budakowski and Tomy, 2003; Morris *et al.*, 2003, 2006; Tomy *et al.*, 2003). Care must be taken in establishing the method so as to avoid problems with ion suppression, and internal standards (^{13}C -labelled or deuterated HBCD isomers) (Morris *et al.*, 2006) should be used routinely for quantification. HPLC on chiral columns has also been used to identify the following separate HBCD enantiomer pairs, (+/-) α -, (+/-) β - and (+/-) γ -HBCD (Heeb *et al.*, 2005; Janák *et al.*, 2005).

TBBP-A is determined only rarely, probably because where it has been determined concentrations are significantly lower than those of the BDEs or HBCD (see, for example, Law *et al.*, 2006b). Even these may be overestimates due to analytical difficulties (Law *et al.*, 2008a). It can be determined using LC-MS, in the method described by Morris *et al.* (2006) concurrently with HBCD in a single analytical run. TBBP-A is used as a reactive flame retardant, primarily in printed circuit boards for electronic equipment such as computers, and so is less likely to leach from the products during use than additive flame retardants. Studies around areas of production and use, when the compound is in its unreacted state, are therefore recommended as a worst-case situation. This suggests that TBBP-A may be more important as an environmental contaminant in Asia than in Europe and North America.

The availability of certified or standard reference materials (CRMs/SRMs) is an important aspect of analytical quality control and method development, and only two are currently available for BFRs. These are SRM1589a (freeze-dried human serum) and SRM 2585 (household dust), both available from the National Institute of Standards and Technology in the USA. SRM1589a is certified for four BDE congeners, with indicative values for three more, while SRM2585 is certified for 15 congeners, including BDE209. In addition, indicative values have been developed for a range of other reference materials (Zhu and Hites, 2003; Kucklick *et al.*, 2004; Stapleton *et al.*, 2006, 2007).

Since 1999, a number of international intercomparison exercises have been organised with the aim of assessing and improving the quality of BFR analysis, the most important are summarised in Covaci *et al.* (2007a). A broad range of matrices have been used, including soils, sediments, fish and bird tissues, reindeer meat and whale blubber. Most have involved the determination of BDEs, but HBCD and TBBP-A were included in a few exercises. A series of exercises conducted within the laboratory proficiency scheme QUASIMEME (Quality Assurance of Information for Marine Environmental Monitoring in Europe) has shown improved comparability over time for a number of BDE congeners (BDE47, BDE99, BDE100, BDE153 and BDE154) (de Boer and Wells, 2006). However, BDE183 and BDE209 still cause serious difficulties for most participating laboratories. Also, only a minority of laboratories can carry out reliable analyses for HBCD and TBBP-A. When examining data reported in the literature, for BDE209 and HBCD in particular, readers should carefully scrutinise the quality assurance information given before accepting data at face value.

2.4 Physicochemical Properties and Their Influence on Environmental Fate and Behaviour

The potential for organic compounds to bioaccumulate is a function of their lipophilicity, usually expressed as the logarithm of the octanol–water partition coefficient, or $\log K_{ow}$. In the UK, the Chemicals Stakeholder Forum assesses compounds using criteria whereby

Table 2.2 Indicative $\log K_{ow}$ values for selected BFRs

Compound	Log K_{ow}	Reference
BDE3	4.8	Palm, Brorström-Lundén and Breivik, (2004)
BDE15	5.0	Wania and Dugani, (2003)
BDE28	5.5	Wania and Dugani, (2003)
BDE47	6.1	Wania and Dugani, (2003)
BDE99	6.6	Wania and Dugani, (2003)
BDE100	6.5	Wania and Dugani, (2003)
BDE153	7.1	Wania and Dugani, (2003)
BDE183	7.1	Wania and Dugani, (2003)
BDE209	10	Wania and Dugani, (2003)
HBCD	5.6	Commission on Life Sciences, (2000)
α -HBCD	4.9–5.3	Hayward, Lei and Wania, (2006)
β -HBCD	5.0–5.4	Hayward, Lei and Wania, (2006)
γ -HBCD	5.3–5.9	Hayward, Lei and Wania, (2006)
TBBP-A	5.9	European Commission, (2006)

potentially bioaccumulative compounds are defined as those for which $\log K_{ow} > 4$, with those for which $\log K_{ow} > 5$ being defined as potentially very bioaccumulative compounds. From the indicative values of $\log K_{ow}$ given in Table 2.2, all of these flame retardant compounds have bioaccumulation potential. (Values are described as indicative as they are derived from a variety of experimental and estimation studies and can carry large uncertainties; see Hayward, Lei and Wania, 2006). For large molecules, this tendency for accumulation is inhibited due to their large size, and BDE183 (722 daltons) and BDE209 (959 daltons) are less bioaccumulative than the di- to hepta-brominated congeners.

Modelling approaches to assess the long-range transport potential of both the BDEs and HBCD have been undertaken (Wania and Dugani, 2003; Drohmann, 2006). For HBCD and highly brominated BDE congeners such as BDE209, it was concluded that they have a very low potential to reach remote areas. The tetra- and penta-brominated congeners were shown to have a similar potential for long-range transport and accumulation in the Arctic as that of hexa- and hepta-chlorinated CBs. This suggests that some BDEs and other BFRs with similar physical properties will undergo long-range transport, deposition and revolatilisation (a process known as the ‘grasshopper effect’; see de Wit, Alaee and Muir, 2006). Subsequently, Ter Schure *et al.* (2004) reported a dominance of particle-associated BDE209 in air over the Baltic Sea, and the detection of BDE209 and HBCD in both abiotic and biotic samples from Arctic and other remote locations (de Wit, Alaee and Muir, 2006; Law *et al.*, 2005, 2006a) forced a reconsideration of these conclusions. Gouin *et al.* (2006) and Breivik *et al.* (2006) have suggested that, as BDE209 is largely associated with atmospheric particles, it has an enhanced ability for long-range transport adsorbed to aerosol particles. For HBCD, modelling of degradation pathways indicated that HBCD is not expected to persist in the aquatic environment (Admon *et al.*, 2007). This work indicated that the first stages of degradation occurred under anaerobic conditions, during which HBCD can be sequentially debrominated to *t, t, t*-cyclodecatriene. Then, under aerobic conditions, this compound is mineralised to CO₂. The authors concluded that the major environmental sink for HBCD would be sediments, while environmental studies indicate very high concentrations in some aquatic biota, such as harbour porpoises (Law *et al.*, 2006b, 2006c).

2.5 Overview of Toxicology

Due to the persistence, bioaccumulation and potential for chronic toxicity in both wildlife and humans, BFRs are of concern (Birnbaum and Staskal, 2004), although the degree of toxicological knowledge to date is inadequate for a full assessment of risks to be made. Initially, it was assumed that the toxicology of BDEs would parallel that of CBs due to the structural similarities (Hooper and McDonald, 2000), possibly including dioxin-like activity for some congeners. Based upon structure–activity relationships with polychlorinated biphenyls, polychlorinated diphenyl ethers and other compounds, some of the persistent and bioaccumulative BDE congeners were thought likely to cause cancer and thyroid and/or neurodevelopmental toxicity in both humans and wildlife. Schechter *et al.* (2003) noted BDE209 as a possible human carcinogen following a 2 year chronic rodent bioassay, although this effect was observed in laboratory animals only at very high levels of exposure. The authors also noted that the penta- and octa-mix PBDE formulations are more bioactive, with possible endocrine, hepatic, reproductive and neurodevelopmental toxicities. Currently, work is also underway to elucidate the toxicity of common congeners of the BDEs (see, for example, Kuiper *et al.*, 2004; Cantón *et al.*, 2006; Muirhead *et al.*, 2006; Hu *et al.*, 2007; Lema *et al.*, 2007). In the most recent study of BDE toxicology, van den Berg (2007) concluded that BDEs can no longer be considered as dioxin-like compounds and that it is now accepted that they may have toxicological similarities with *ortho*-substituted CBs such as CB153. Endocrine-related effects have also been reported for several BDE congeners and their hydroxyl metabolites. *In vitro* effects of OH-BDEs have been observed with the oestrogen receptor, thyroid hormone transporting protein (trans-thyretin, TTR) and the steroidogenic enzymes CYP17 and CYP19. Recent semi-chronic studies within the EU FIRE programme with several BFRs, including penta-BDE and deca-BDE, have shown that similar effects can also be seen *in vivo*.

Similar isomer-specific studies are also needed for HBCD. Acute toxicity tests sponsored by industry have shown low toxicity for the commercial formulation (dominated by γ -HBCD) (Drohmann, 2006). However, in wildlife, the α -HBCD isomer is predominant (Law *et al.*, 2006c). Also, Darnerud (2003) had concluded earlier that there was a lack of relevant studies of high quality that could form a basis for risk assessment of HBCD. Law *et al.* (2006c) noted that the database on nonlethal effects is still incomplete and highlighted the need for more information on neurotoxicology, developmental toxicity and the potential for endocrine disruption. Covaci *et al.* (2006) noted a range of effects from HBCDs including developmental toxicity and effects on the thyroid hormone system and indicated that further research on the levels at which these effects occur is required.

2.6 Environmental Levels – Present, Past and Future Temporal Trends

Initial concern regarding BFRs was raised by studies in Sweden in 1980, which demonstrated the presence of polybrominated compounds (PBDEs) in environmental samples (Andersson and Blomkvist, 1981). Subsequently, this concern was heightened by further studies, which showed an exponential increase in levels of BDEs in human milk samples during the 1990s (Meironyté, Norén and Bergman, 1999). This sparked an interest within the European Union and began a programme of risk assessments of the continued

production and use of BFRs, which is ongoing and has so far led to the removal of all three PBDE products from the EU market. Subsequently, BDE congener concentrations relevant to the penta- and octa-products in human milk in Sweden have begun to decline (Meironyté and Norén, 2001). In the USA and Canada, where use of the penta-BDE product has continued beyond the date of the EU ban, concentrations in human milk are much higher than those in Europe and the Far East (Figure 2.3) and are probably still increasing. Temporal trends for BFRs have been examined in a variety of matrices and locations, and I propose to concentrate on these rather than on a catalogue of environmental concentrations. Readers are referred to the original publications for these for the most part, or to recent comprehensive reviews (Covaci *et al.*, 2006; de Wit, Alaee and Muir, 2006; Law *et al.*, 2006a, 2008b) and the references therein.

BFRs bioaccumulate in both aquatic and terrestrial food chains and are commonly detected in samples of air, household dust, sediments and soils, sewage sludges, birds and their eggs, fish and marine mammals (Law *et al.*, 2006a). BDE209 is generally not detected in aquatic biota, but can accumulate in terrestrial food chains with a biomagnification factor < 1. Earthworms may be a significant vector for this (Law *et al.*, 2006a). BDE209 has been reported in fish, etc., at concentrations close to the limit of detection, but these data need to be treated with caution due to analytical difficulties in the determination of this congener listed above.

A number of recent trend studies are summarised below. Settled sediments from lakes and undisturbed (preferably anoxic) sediments represent a historical record of contaminant

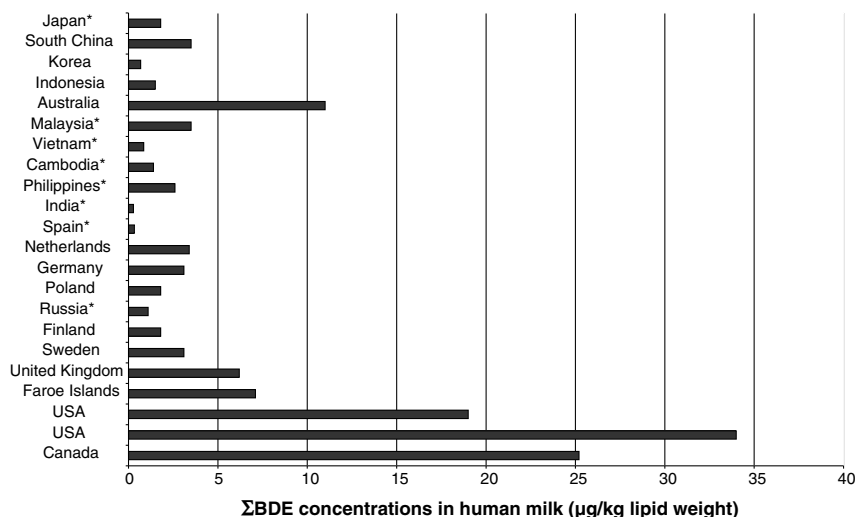

Figure 2.3 International comparison of median (*mean) concentrations of summed BDE congeners ($\mu\text{g}/\text{kg}$ lipid weight) in human milk. After Toms *et al.*, 2007, with supplementary data. Data are taken from Baumann *et al.*, 2003; Bi *et al.*, 2006; Bordajandi, Abad and González, 2008; Darnerud *et al.*, 2002; Eslami *et al.*, 2006; Fangstrom *et al.*, 2004; Fürst, 2006; Jaraczewska *et al.*, 2006; Kalantzi *et al.*, 2004; Ryan *et al.*, 2002; Schechter *et al.*, 2003, 2006; Strandman, Koistinen and Vartiainen, 2000; Sudaryanto *et al.*, 2005; Toms *et al.*, 2007; Tsydenova *et al.*, 2007

concentrations scavenged from the overlying waters by sediment particles, which are later deposited in the bed sediments. Three dated sediment cores from locations in western Europe (the Drammenfjord in Norway, the western Wadden Sea in the Netherlands and Lake Woserin in Germany) analysed for 14 BDE congeners showed a time-dependent pattern in BDE distribution (Zegers *et al.*, 2003). Two of the three commercial formulations could be distinguished. The penta-PBDE product was clearly present from the beginning of the 1970s, but the deca-PBDE product only appears in the late 1970s. This is in agreement with data for the industrial production of these two formulations and, in the environment overall, concentration trends generally parallel the production data as far as these can be accessed and assessed. The octa-PBDE product was not observed. In the cores from the Netherlands and Germany, concentrations of BDE congeners associated with the penta-PBDE product were levelling off in the most recent layers (1995 and 1997) whereas those in Norway were still increasing in 1999. The levels of BDE209 decreased in the most recent layers of all three cores. The absence of all BDE congeners in the older (deeper) layers of all three cores, as well as in several 100–150 million year old layers of clay from Kimmeridge, UK, indicated that these BDE congeners are not produced naturally, although some methoxy-BDEs are produced by marine animals (Teuten, Xu and Reddy, 2005). In a similar study of three sediment cores taken in Japan, the highest concentrations of summed BDEs, BDE209 and HBCD were observed in the surface layers of each core. PBDEs appeared in the layer dated to the mid 1940s, while HBCD was not detected until the early 1970s. Declining inputs of congeners from the penta- and octa-PBDE products following their discontinued use in the 1990s has stemmed increases in concentrations for these compounds (Tanabe *et al.*, 2007). Chen *et al.* (2007) studied three sediment cores from the Pearl River Estuary in south China. Summed BDE concentrations (without BDE209) increased gradually from the mid 1970s to the early 1990s, followed by differing trends in the three locations. BDE209 concentrations remained constant until 1990 and thereafter increased exponentially, with doubling times of 2.6 to 6.4 years, reflecting the increasing market demands for the deca-PBDE product in China in the 1990s due to growth in the electronics manufacturing industry. In a core from Lake Ontario, Canada, concentrations of BDEs (tri- to hepta-bromo BDEs, BDE209) and BTBPE (1,2-bis-(2,4,6-tribromophenoxy)ethane) began rising steeply during the early 1980s (Qiu, Marvin and Hites, 2007). Sudaryanto *et al.* (2007) determined BDEs in 119 sediment samples from several countries in Asia and three sediment cores from Tokyo Bay. Higher concentrations of BFRs were found in coastal waters of Korea, which is one of the major consumers in Asia. BDE209 was the dominant congener (80–100%) in all countries, whereas levels of BDE congeners deriving from the penta- and octa-PBDE products were much lower. Analyses of the sediment cores showed that concentrations of BDE209 and HBCD increased in the upper layers, coincident with the growing use of these commercial products.

Temporal trends of BFRs in lake trout from Ontario over the period 1979–2004 were studied by Tomy *et al.* (2007). Summed BDE concentrations showed a linear increase from 1979 to 1998, followed by an apparent decrease in 2004. Concentrations of HBCD were between 2.0 and 4.1 $\mu\text{g}/\text{kg}$ lipid weight, and showed a declining trend during sampling years. BTBPE (now replacing the penta-PBDE product) showed a strong linear increase from 1979 to 1998, followed by a small decline in 2004. BDE209 showed a linear increase in concentrations over the whole period, consistent with usage patterns.

Takahashi *et al.* (2007) reviewed recent studies on BFRs in the Asia–Pacific region. BDE concentrations in mussels from Hong Kong and Korea were higher than in those from other

locations (Cambodia, China, India, Malaysia, the Philippines and Vietnam). The analysis of archived marine mammal samples from Asian waters taken from a specimen bank have demonstrated that, in general, environmental levels of BDEs and HBCD have risen significantly over the past 30 years (Tanabe *et al.*, 2007). In striped dolphin, for example, mean concentrations of summed BDEs increased from 13 µg/kg lipid weight in 1978 to 640 µg/kg lipid weight in 2003. An increasing trend was also observed for HBCD, from 12 µg/kg lipid weight in 1978 to 710 µg/kg lipid weight in 2003. In the UK, concentrations of BDEs, HBCD and TBBP-A have been determined in the blubber of harbour porpoises deriving from the national Cetacean Strandings Project. Maximum concentrations observed were:

Summed di- to octa-BDE congeners	15 700 µg/kg lipid weight
BDE209	Not detected in any samples
HBCD	21 300 µg/kg lipid weight
TBBP-A	38 µg/kg lipid weight

Investigation of possible time trends in HBCD concentrations in harbour porpoises from the UK indicated a sharp increase from about 2001 onward, which was not confounded by age, sex, nutritional status or location (Law *et al.*, 2006b). This may have been a result of changing patterns in the use of HBCD following controls on two PBDE formulations in the EU. A later study, however, showed a significant decrease in HBCD concentrations to have occurred between 2003 and 2004, possibly as a result of the closure of a manufacturing plant in NE England and the introduction of improved emission controls during use (Law *et al.*, 2008a).

Hassanin *et al.* (2005) determined BDEs in archived pasture samples collected in the UK between 1930 and 2004. BDEs could not be routinely detected in samples before 1970. The general trend thereafter was: (1) a rise through the 1970s, (2) a mini-peak in the mid 1980s and (3) a more recent decline consistent with controls on the use of the penta- and octa-mix commercial products in the EU (Law *et al.*, 2006a).

The presence of BDE209 at low but readily detectable concentrations in a variety of organisms and lake sediments from the Arctic shows that even very nonvolatile chemicals can reach this polar region (Muir, Alaee and de Wit, 2007), presumably due to transport on atmospheric particles. Overall, concentrations of BFRs measured to date in the Arctic are very low compared to those of 'legacy' POPs. There are a number of semi-volatile BFRs which, due to their relatively long predicted atmospheric half-lives, could undergo airborne transport and which therefore represent good candidates for future surveys of spatial and temporal trends, both in the Arctic and elsewhere (Muir and Howard, 2006). For discussion purposes, Muir and Howard list 30 chemicals with high predicted bioconcentration and a low rate of biodegradation and 28 with long-range atmospheric transport potential. There is now a vast quantity of data concerning BDEs, and some of this effort could in the future be diverted to the study of 'novel' compounds.

2.7 Human Exposure – Magnitude and Relative Significance of Pathways

In a number of studies, intake of BFRs from consumption of fish and shellfish have been shown to form a significant (or the dominant) part of the total dietary intake. In a US study,

fish exhibited the highest concentrations of BDEs and HBCD, followed by meat and dairy products. As meat is consumed to a much greater degree than fish in the USA, meat was the primary source of dietary intake of BDEs (Schechter *et al.*, 2007). In a more localised study around Lake Mjøsa in Norway, Thomsen *et al.* (2007a) studied the relationship between elevated levels of BDEs in fish and the anglers who consumed them. A study of 66 anglers showed their individual dietary intakes to correlate well with serum concentrations for several of the lower brominated congeners. Median dietary intake for summed BDEs was 30 ng/kg body weight/day, the highest reported. The consumption of fish from the contaminated lake was 98.7% of total dietary exposure. Serum levels of HBCD were also correlated to the calculated BDE intake, although HBCD intakes could not be estimated.

Sobrado *et al.* (2007) determined BDEs in commercial fishery and aquaculture products from Spain, studying 49 samples from 11 groups. Maximum summed BDE concentrations ranged from 0.07 µg/kg wet weight in raw tuna to 3.5 µg/kg wet weight in salmon, and were higher in the more fatty samples. In samples from Catalonia, Spain, collected in 2006, analysis of food samples showed the highest summed BDE concentrations to occur in shellfish (427 µg/kg wet weight), followed by oils and fats (259 µg/kg wet weight) and eggs (80 µg/kg wet weight) (Bocio *et al.*, 2007). Dietary intake for a male of 70 kg was 86 ng/day (1.2 ng/kg body weight/day). This showed a 30% reduction since an earlier study in 2000.

In China, the median intake of summed BDEs via fish consumption was 1.7 to 13 ng/day (0.02 to 0.2 ng/kg body weight/day for a 70 kg adult). Intakes via fish consumption are, therefore, at the lower end of the global range, although the authors noted that human exposure via inhalation in China is relatively high (Meng *et al.*, 2007). HBCD, TBBP-A and summed BDEs were studied in a total diet food study from Japan in 2002 and 2005 (Murata *et al.*, 2007). Estimated dietary intakes for an adult were 2.2, 1.1 and 2.3 ng/kg body weight/day (respectively) in 2002 and 1.4, 0.1 and 1.4 ng/kg body weight/day (respectively) in 2005.

The study by Hites *et al.* (2004) of BDEs in farmed and wild salmon promoted discussions regarding the consumption of fatty fish. The health benefits of omega-3 fatty acids are clear, but the consumption of (especially) farmed fish exposes consumers to higher intakes of lipophilic contaminants (including BDEs) and so presumably to an additional health risk (Law *et al.*, 2006a). The development of less contaminated feeds for use in salmon farms may be a way of reducing this risk.

Covaci *et al.* (2007b) also studied BDEs in fish oil dietary supplements. Despite being taken daily, the authors concluded that their consumption did not significantly increase daily intakes of BDEs. The median daily intake from dietary supplements was 8 and 16 times lower than the intake from fish consumption alone or from a total diet, respectively.

Trudel *et al.* (2007) studied dietary exposure with the aim of understanding why concentrations in human milk from North America are 10 to 100 times higher than in Europe. The range of exposure for infants in North America was 8–800 ng/kg body weight/day, while in Europe it was 1–130 ng/kg body weight/day. Infants had the highest exposures, followed by toddlers and children. Teenagers and adults had the lowest exposures.

Human milk has been widely studied in relation to BFRs, particularly the BDEs. Figure 2.3 summarises data worldwide in order to demonstrate overall trends. As can be seen, it is generally the case that the highest concentrations are observed in the USA and Canada, intermediate concentrations in the UK and the Faroe Islands, and lower concentrations in the rest of Europe and the Far East. Australia does stand out as higher than expected on this trend basis.

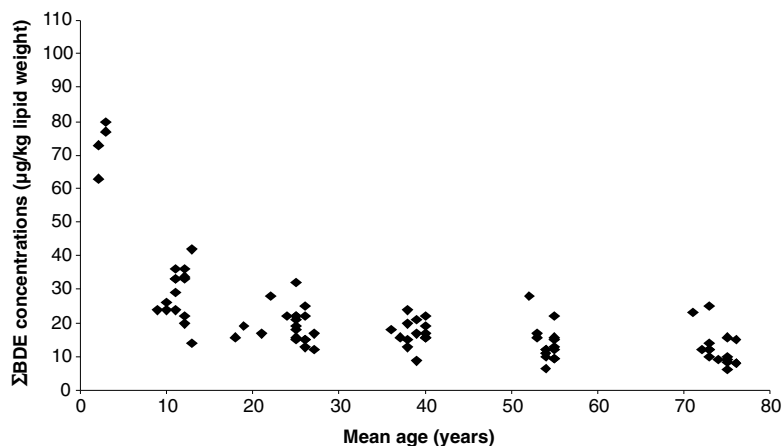

Figure 2.4 Summed BDE congener concentrations ($\mu\text{g}/\text{kg}$ lipid weight) in each pool of blood serum analysed by the respective mean age (in years) of donors in each pool. Each data point represents a pool of up to 100 blood samples. (Reproduced by permission from *Environmental Science and Technology, Higher Accumulation of Polybrominated Diphenyl Ethers in Infants Than in Adults*, by Toms, L.-M. L., Harden, F., Paepke, O., Ryan, J. J., Hobson, P., Mueller, J. F., **42**(19), 2510–2515. Copyright 2008 American Chemical Society)

In a study of human blood serum in Australia undertaken in 2002/2003 and 2004/2005, a trend by age was observed with elevated summed BDE concentrations in the 0–4 years and <16 (5 to 15 years) age groups compared to the >16 years age groups (Figure 2.4). The PBDE concentrations in the youngest groups were up to a factor of 4 higher than those in the older groups, and any decrease with age >20 years old were small. These data presumably reflect a greater exposure from household dust to the youngest children, reducing with age.

Although it is possible to document differences and trends in human exposure to BFRs and the consequent levels in human milk and blood, assessing their significance in toxicological terms is much more difficult. Knowledge of human toxicology for BFRs is incomplete, i.e. whether the levels observed in humans (and, indeed, wildlife) are high enough to generate effects is unclear (Birnbaum and Staskal, 2004). A recent report has linked summed BDE concentrations in human milk with the prevalence of cryptorchidism in boys from Denmark and Finland (Main *et al.*, 2007). The concentration of summed BDEs was significantly higher in human milk from the mothers of boys with cryptorchidism ($p < 0.007$). Adverse effects on endocrine function (in this case, testicular descent and hormonal function) may result from either prenatal or lactational exposure, as may neurobehavioural effects, within specific developmental time windows (Hooper and McDonald, 2000). If this is so, then the health of foetuses and infants can only be protected by reducing the mothers' exposure to BFRs and so their body burdens. Replacing some of the current use BFRs by less lipophilic, persistent and potentially toxic alternatives would be the preferred strategy, although effective limits to emissions of current BFRs would also contribute. Given the higher concentrations observed in human milk from North America than in other areas of the world, children in the USA and Canada are the most at risk currently. Overall, additional information is needed on human toxicology for BFRs before risks can be fully assessed.

2.8 Summary and Conclusions

Of the main flame retardants currently in use, the PBDEs and HBCD are ubiquitous environmental contaminants with the ability to be transported to remote areas. BDE209 generally dominates the BDE congener profile in sediments. TBBP-A has been detected at only low concentrations to date, but additional studies are needed in proximity to sites of production and use, the latter largely in Asia as a worst-case scenario.

There is now a large amount of data on environmental levels and trends for BDEs. In order to develop a fuller picture of the current situation regarding the full range of BFRs currently in use, some of this effort should in the future be diverted to the study of 'novel' compounds for which data are sparse or nonexistent.

BDE209 is present in many sediments at high concentrations, but has a low bioaccumulation potential. It does accumulate in the tissues of terrestrial birds, but either not or only to very low concentrations in aquatic species (Law *et al.*, 2006a). There is still, however, concern that BDE209 may debrominate in the environment to yield more mobile and potentially toxic congeners. BDE209 is photolytically labile and studies have shown debromination to tetra- to nona-bromo congeners under both UV light in the laboratory and outdoor sunlight (Söderström *et al.*, 2004). Laboratory experiments have also shown debromination of BDE209 fed to carp using spiked food pellets (Stapleton *et al.*, 2004). At least seven penta- to octa-brominated congeners were formed during 60 days exposure, including BDE153 and BDE154. The true significance of BDE209 debromination in the environment, however, remains to be established.

There is no doubt that the use of BFRs has a societal benefit in reducing the frequency, severity and impact of fires. However, many of the current compounds are persistent, bioaccumulative and (potentially, at the least) toxic to humans and wildlife. Whether the most appropriate BFRs are currently in use or whether other currently available or new compounds would be as effective with fewer environmental disbenefits remains to be established.

Acknowledgements

CEFAS work on BFRs has been funded by the (now defunct) UK Department of the Environment, the UK Department for Environment, Food and Rural Affairs and the Bromine Science and Environmental Forum.

References

- Admon, S., Davis, J. W., Gonsior, S. J., Friederich, U., Hunziker, R. W., Ariano, J. M., Weiss, M. (2007) Environmental fate of hexabromocyclododecane (HBCD), the degradation pathway. In Proceedings of the 4th International Workshop on *Brominated Flame Retardants*, Amsterdam, The Netherlands, 24–27 April 2007 (unpaginated).
- Andersson, Ö., Blomkvist, G. (1981) Polybrominated aromatic pollutants found in fish in Sweden. *Chemosphere*, **10**: 1051–1060.
- Baumann, B., Hijman, W., van Beuzekom, S., Hoogerbrugge, R., Houweling, D., Zeilmaker, M. (2003) PBDEs in human milk from the Dutch 1998 monitoring programme. *Organohal. Cpds*, **61**: 187–190.

- Bi, X., Qu, W., Sheng, G., Zhang, W., Mai, B., Chen, D., Yu, L., Fu, J. (2006) Polybrominated diphenyl ethers in South China maternal and fetal blood and breast milk. *Environ. Pollut.*, **144**: 1024–1030.
- Birnbaum, L. S., Staskal, D. F. (2004) Brominated flame retardants: cause for concern? *Environ. Health Perspect.*, **112**: 9–17.
- Bocio, A., Domingo, J. L., Marti-Cid, R., Mata, E., Teixidó, A., Llobet, J. M. (2007) Dietary intake of PBDEs by the population of Catalonia, Spain. Temporal trend. *Organohal. Cpds*, **69**: 2710–2712.
- Bordajandi, L. R., Abad, E., González, M. J. (2008) Occurrence of PCBs, PCDD/Fs, PBDEs and DDTs in Spanish breast milk: enantiomeric fraction of chiral PCBs. *Chemosphere*, **70**: 567–575.
- Breivik, K., Wania, F., Muir, D. C. G., Alaee, M., Backus, S., Pacepavicius, G. (2006) Empirical and modeling evidence of the long-range atmospheric transport of decabromodiphenyl ether. *Environ. Sci. Technol.*, **40**: 4612–4618.
- BSEF (2007) www.bsef.com, accessed 23 October 2007.
- Budakowski, W., Tomy, G. (2003) Congener-specific analysis of hexabromocyclododecane by high-performance liquid chromatography/electrospray tandem mass spectrometry. *Rapid Commun. Mass Spectrom.*, **17**: 1399–1404.
- Cantón, R. F., Sanderson, J. T., Nijmeijer, S., Bergman, Å., Letcher, R. J., van den Berg, M. (2006) *In vitro* effects of brominated flame retardants and metabolites on CYP17 catalytic activity: a novel mechanism of action? *Toxicol. Appl. Pharmacol.*, **216**: 274–281.
- Chen, S.-J., Luo, X.-J., Lin, Z., Li, K.-C., Peng, X.-Z., Mai, B.-X., Ran, Y., Zeng, E. Y. (2007) Time trends of polybrominated diphenyl ethers in sediment cores from the Pearl River Estuary, South China. *Environ. Sci. Technol.*, **41**: 5595–5600.
- Commission on Life Sciences (2000) *Toxicological Risks of Selected Flame-Retardant Chemicals*. National Academy Press, Washington DC, USA, 534 pp. ISBN 0-309-59232-1.
- Covaci, A., Gerecke, A. C., Law, R. J., Voorspoels, S., Kohler, M., Heeb, N. V., Leslie, H., Allchin, C. R., de Boer, J. (2006) Hexabromocyclododecanes (HBCDs) in the environment and humans: a review. *Environ. Sci. Technol.*, **40**: 3679–3688.
- Covaci, A., Voorspoels, S., Ramos, L., Neels, H., Blust, R. (2007a) Recent developments in the analysis of brominated flame retardants and brominated natural compounds. *J. Chromatog. A*, **1153**: 145–171.
- Covaci, A., Voorspoels, S., Vetter, W., Gelbin, A., Jorens, P. G., Blust, R., Neels, H. (2007b) Anthropogenic and naturally occurring organobrominated compounds in fish oil dietary supplements. *Environ. Sci. Technol.*, **41**: 5237–5244.
- Darnerud, P. O. (2003) Toxic effects of brominated flame retardants in man and wildlife. *Environ. Int.*, **29**: 841–853.
- Darnerud, P. O., Aune, M., Atuma, S., Becker, W., Bjerselius, R., Cnattingius, S., Glynn, A. (2002) Time trend of polybrominated diphenyl ether (PBDE) levels in breast milk from Uppsala, Sweden, 1996–2001. *Organohal. Cpds*, **58**: 233–236.
- de Boer, J., Allchin, C., Law, R., Zegers, B., Boon, J. P. (2001) Method for the analysis of polybrominated diphenylethers in sediments and biota. *TrAC*, **20**: 591–599.
- de Boer, J., Wells, D. E. (2006) Pitfalls in the analysis of brominated flame retardants in environmental, human and food samples – including results of three international interlaboratory studies. *TrAC*, **25**: 364–372.
- de Wit, C. A., Alaee, M., Muir, D. C. G. (2006) Levels and trends of brominated flame retardants in the Arctic. *Chemosphere*, **64**: 209–233.
- Drohmann, D. (2006) HBCD: facts and insinuations. *Environ. Sci. Technol.*, **40**: 1.
- Eisenreich, S., Munn, S., Pakalin, S. (2007) Risk assessment of PBDEs in the European Union – process and update. In Proceedings of the 4th International Workshop on *Brominated Flame Retardants*, Amsterdam, The Netherlands, 24–27 April 2007 (unpaginated).
- Eslami, B., Koizumi, A., Ohta, S., Inoue, K., Aozasa, O., Harada, K., Yoshinaga, T., Date, C., Fujii, S., Fujimine, Y., Hachiya, N., Hirotsawa, I., Koda, S., Kusaka, Y., Murata, K., Nakatsuka, H., Omae, K., Saito, N., Shimbo, S., Takenaka, K., Takeshita, T., Todoriki, H., Wada, Y., Watanabe, T., Ikeda, M. (2006) Large-scale evaluation of the current level of polybrominated diphenyl ethers (PBDEs) in breast milk from 13 regions of Japan. *Chemosphere*, **63**: 554–561.

- European Commission (2006) 2, 2', 6, 6'-Tetrabromo-4, 4'-isopropylidenediphenol (tetrabromobiphenol-A or TBBP-A): summary risk assessment report, 20 pp.
- European Commission (2008) Risk assessment report on hexabromocyclododecane. Final draft, May 2008, 492 pp.
- Fangstrom, B., Strid, A., Athanassiadis, I., Grandjean, P., Weihe, P., Bergman, Å. (2004) A retrospective time trend study of PBDEs and PCBs in human milk from the Faroe Islands. *Organohal. Cpds*, **66**: 2829–2832.
- Fürst, P. (2006) Dioxins, polychlorinated biphenyls and other organohalogen compounds in human milk. Levels, correlations, trends and exposure through breastfeeding. *Molecular Nutrition and Food Research*, **50**: 922–933.
- Gouin, T., Thomas, G. O., Chaemfa, C., Harner, T., Mackay, D., Jones, K. C. (2006) Concentrations of decabromodiphenyl ether in air from Southern Ontario: implications for particle-bound transport. *Chemosphere*, **64**: 256–261.
- Guan, Y.-F., Wang, J.-Z., Ni, H.-G., Luo, X.-J., Mai, B.-X., Zeng, E. Y. (2007) Riverine inputs of polybrominated diphenyl ethers from the Pearl River Delta (China) to the coastal ocean. *Environ. Sci. Technol.*, **41**: 6007–6013.
- Harrad, S., Hunter, S. (2004) Spatial variation in atmospheric levels of PBDEs in passive air samples on an urban–rural transect. *Organohal. Cpds*, **66**: 3786–3792.
- Hassanin, A., Johnston, A. E., Thomas, G. O., Jones, K. C. (2005) Time trends of atmospheric PBDEs inferred from archived U.K. herbage. *Environ. Sci. Technol.*, **39**: 2436–2441.
- Hayward, S. J., Lei, Y. D., Wania, F. (2006) Comparative evaluation of three high-performance liquid chromatography-based K_{ow} estimation methods for highly hydrophobic organic compounds: polybrominated diphenyl ethers and hexabromocyclododecane. *Environ. Toxicol. Chem.*, **25**: 2018–2027.
- Heeb, N., Schweizer, W. B., Kohler, M., Gerecke, A. (2005) Structure elucidation of hexabromocyclododecanes – a class of compounds with a complex stereochemistry. *Chemosphere*, **61**: 65–73.
- Hites, R. A., Foran, J. A., Schwager, S. J., Knuth, B. A., Hamilton, M. C., Carpenter, D. O. (2004) Global assessment of polybrominated diphenyl ethers in farmed and wild salmon. *Environ. Sci. Technol.*, **38**: 4945–4949.
- Hooper, K., McDonald, T. A. (2000) The PBDEs: an emerging environmental challenge and another reason for breast-milk monitoring programs. *Environ. Health Perspect.*, **108**: 387–392.
- Hu, X.-Z., Xu, Y., Hu, D.-C., Hui, Y., Yang, F.-X. (2007) Apoptosis induction on human hepatoma cells Hep G2 of decabrominated diphenyl ether (PBDE-209). *Toxicol. Lett.*, **171**: 19–28.
- Ibarra, C., Douwes, J., Pearce, N., Harrad, S. (2007) Polybrominated diphenyl ethers (PBDEs) in household dust from Wellington, New Zealand and Birmingham, United Kingdom. In Proceedings of the 4th International Workshop on *Brominated Flame Retardants*, Amsterdam, The Netherlands, 24–27 April 2007 (unpaginated).
- Isobe, T., Ramu, K., Kajiwara, N., Takahashi, S., Lam, P. K. S., Jefferson, T. A., Zhou, K., Tanabe, S. (2007) Isomer specific determination of hexabromocyclododecanes (HBCDs) in small cretaceans from the South China Sea – levels and temporal variation. *Mar. Pollut. Bull.*, **54**: 1139–1145.
- Janák, K., Covaci, A., Voorspoels, S., Becher, G. (2005) Hexabromocyclododecane in marine species from the Western Scheldt estuary: diastereoisomer- and enantiomer-specific accumulation. *Environ. Sci. Technol.*, **39**: 1987–1994.
- Jaraczewska, K., Lulek, J., Covaci, A., Voorspoels, S., Kaluba-Skotarczak, A., Drews, K., Schepens, P. (2006) Distribution of polychlorinated biphenyls, organochlorine pesticides and polybrominated diphenyl ethers in human umbilical cord serum, maternal serum and milk from Wielkopolska region. *Poland Sci. Total Environ.*, **372**: 20–31.
- Kalantzi, O. I., Martin, F. L., Thomas, G. O., Alcock, R. E., Tang, H. R., Drury, S. C., Carmichael, P. L., Nicholson, J. K., Jones, K. C. (2004) Different levels of polybrominated diphenyl ethers (PBDEs) and chlorinated compounds in breast milk from two U.K. regions. *Environ. Health Perspect.*, **112**: 1085–1091.
- Korytár, P., Covaci, A., Leonards, P. E. G., de Boer, J., Brinkman, U. A. Th. (2005) Comprehensive two-dimensional gas chromatography of polybrominated diphenyl ethers. *J. Chromatog. A*, **1100**: 200–207.

- Korytár, P., Haglund, P., de Boer, J., Brinkman, U. A. Th. (2006) Comprehensive two-dimensional gas chromatography for the analysis of halogenated micro-contaminants. *TrAC*, **25**: 373–396.
- Kucklick, J. R., Tuerk, K. J. S., van der Pol, S. S., Schantz, M. M., Wise, S. A. (2004) Polybrominated diphenyl ether congeners and toxaphene in selected marine standard reference materials. *Anal. Bioanal. Chem.*, **378**: 1147–1151.
- Kuiper, R. V., Bergman, Å., Vos, J. G., van den Berg, M. (2004) Some polybrominated diphenyl ether (PBDE) flame retardants with wide environmental distribution inhibit TCDD-induced EROD activity in primary cultured carp (*Cyprinus carpio*) hepatocytes. *Aquat. Toxicol.*, **68**: 129–139.
- Law, R. J., Kohler, M., Heeb, N. V., Gerecke, A. C., Schmid, P., Voorspoels, S., Covaci, A., Becher, G., Janák, K., Thomsen, C. (2005) Hexabromocyclododecane challenges scientists and regulators. *Environ. Sci. Technol.*, **39**: 281A–287A.
- Law, R. J., Allchin, C. R., de Boer, J., Covaci, A., Herzke, D., Lepom, P., Morris, S., Tronczynski, J., de Wit, C. A. (2006a) Levels and trends of brominated flame retardants in the European environment. *Chemosphere*, **64**: 187–208.
- Law, R. J., Bersuder, P., Allchin, C. R., Barry, J. (2006b) Levels of the flame retardants hexabromocyclododecane and tetrabromobisphenol A in the blubber of harbour porpoises (*Phocoena phocoena*) stranded or bycaught in the UK, with evidence for an increase in HBCD concentrations in recent years. *Environ. Sci. Technol.*, **40**: 2177–2183.
- Law, R. J., Kohler, M., Heeb, N. V., Gerecke, A. C., Schmid, P., Voorspoels, S., Covaci, A., Becher, G., Janák, K., Thomsen, C. (2006c) Response to 'HBCD: facts and insinuations'. *Environ. Sci. Technol.*, **40**: 2.
- Law, R. J., Bersuder, P., Barry, J., Wilford, B. H., Allchin, C. R., Jepson, P. D. (2008a) A significant downturn in levels of hexabromocyclododecane in the blubber of harbor porpoises (*Phocoena phocoena*) stranded or bycaught in the UK: an update to 2006. *Environ. Sci. Technol.*, **42**: 9104–9109.
- Law, R. J., Herzke, D., Harrad, S., Morris, S., Bersuder, P., Allchin, C. R. (2008b) Levels and trends of HBCD and BDEs in the European and Asian environments, with some information for other BFRs. *Chemosphere*, **73**: 223–241.
- Lema, S. C., Schultz, I. R., Scholz, N. L., Incardona, J. P., Swanson, P. (2007) Neural defects and cardiac arrhythmia in fish larvae following embryonic exposure to 2,2',4,4'-tetrabromodiphenyl ether (PBDE 47). *Aquat. Toxicol.*, **82**: 296–307.
- Luo, Q., Cai, Z. W., Wong, M. H. (2007) Polybrominated diphenyl ethers in fish and sediment from river polluted by electronic waste. *Sci. Total Environ.*, **383**: 115–127.
- Main, K. M., Kiviranta, H., Virtanen, H. E., Sundqvist, E., Tuomisto, J. T. (2007) Flame retardants in placenta and breast milk and cryptorchidism in newborn boys. *Environ. Health Perspect.*, **115**: 1519–1526.
- Meironyté, D., Norén, K. (2001) Polybrominated diphenyl ethers in Swedish human milk. The follow-up study. In Proceedings of the 2nd International Workshop on *Brominated Flame Retardants*, Stockholm, Sweden, 14–16 May 2001, pp. 303–305.
- Meironyté, D., Norén, K., Bergman, Å. (1999) Analysis of polybrominated diphenyl ethers in Swedish human milk. A time-related trend study, 1992–1997. *J. Toxicol. Environ. Health*, **58**: 329–341.
- Meng, X.-Z., Zeng, E. Y., Yu, L.-P., Guo, Y., Mai, B.-X. (2007) Assessment of human exposure to polybrominated diphenyl ethers in China via fish consumption and inhalation. *Environ. Sci. Technol.*, **41**: 4882–4887.
- Morris, S., Allchin, C. R., Bersuder, P., Zegers, B., Hafika, J. J. H., Boon, J. P., Brandsma, S. H., Kruijt, A. W., van der Veen, I., van Hesseligen, J., de Boer, J. (2003) A new LC-MS method for the detection and quantification of hexabromocyclododecane diastereoisomers and tetrabromobisphenol-A flame retardants in environmental samples. *Organohal. Cpd.*, **60**: 436–439.
- Morris, S., Bersuder, P., Allchin, C. R., Zegers, B., Boon, J. P., Leonards, P. E. G., de Boer, J. (2006) Determination of the brominated flame retardant, hexabromocyclododecane, in sediments and biota by liquid chromatography–electrospray ionisation mass spectrometry. *TrAC*, **25**: 343–349.
- Muir, D. C. G., Alaei, M., de Wit, C. (2007) Brominated flame retardants in the Arctic – trends, pathways and new candidates. In Proceedings of the 4th International Workshop on *Brominated Flame Retardants*, Amsterdam, The Netherlands, 24–27 April 2007 (unpaginated).

- Muir, D. C. G., Howard, P. H. (2006) Are there other persistent organic pollutants? A challenge for environmental chemists. *Environ. Sci. Technol.*, **40**: 7157–7166.
- Muirhead, E. K., Skillman, A. D., Hook, S. E., Schultz, I. R. (2006) Oral exposure of PBDE-47 in fish: effects in Japanese medaka (*Oryzias latipes*) and fathead minnows (*Pimephales promelas*). *Environ. Sci. Technol.*, **40**: 523–528.
- Murata, S., Nakagawa, R., Ashikuza, Y., Hori, T., Yasutake, D., Tobiishi, K., Sasaki, K. (2007) Brominated flame retardants (HBCD, TBBPA and Σ PBDEs) in market basket food samples of northern Kyushu district in Japan. *Organohal. Cpds*, **69**: 1985–1988.
- Palm, A., Brorström-Lundén, E., Breivik, K. (2004) Transport and fate of polybrominated diphenyl ethers in the Baltic and Arctic regions. Report to the Nordic Council of Ministers, TemaNord Vol. 554, Appendix 1, pp. 65–75. Nordic Council of Ministers, Copenhagen, Denmark.
- Qiu, X., Marvin, C. H., Hites, R. A. (2007) Dechlorane plus and other flame retardants in a sediment core from Lake Ontario. *Environ. Sci. Technol.*, **41**: 6014–6019.
- Qu, W., Bi, X., Sheng, G., Lu, S., Fu, J., Yuan, J., Li, L. (2007) Exposure to polybrominated diphenyl ethers among workers at an electronic waste dismantling region in Guangdong, China. *Environ. Int.*, **33**: 1029–1034.
- Ryan, J. J., Patry, B., Mills, P., Beaudoin, N. G. (2002) Recent trends in levels of brominated diphenyl ethers (BDEs) in human milks from Canada. *Organohal. Cpds*, **58**: 173–176.
- Schechter, A., Pavuk, M., Pöpke, O., Ryan, J. J., Birnbaum, L., Rosen, R. (2003) Polybrominated diphenyl ethers (PBDEs) in U.S. mothers' milk. *Environ. Health Perspect.*, **111**: 1723–1729.
- Schechter, A., Pöpke, O., Harris, T. R., Tung, K. C. (2006) Partitioning of polybrominated diphenyl ethers (PBDE) congeners in human blood and milk. *Toxicol. Environ. Chem.*, **88**: 319–324.
- Schechter, A., Pöpke, O., Harris, T. R., Musumba, A., Ryan, J. J., Ramaskrishnan, V., Shah, N., Streater, S. (2007) Polybrominated diphenyl ethers and hexabromocyclododecane in the United States: levels in human blood and milk, food, air, fast food and environmental samples. In Proceedings of the 4th International Workshop on *Brominated Flame Retardants*, Amsterdam, The Netherlands, 24–27 April 2007 (unpaginated).
- Sjödin, A., Carlsson, H., Thuresson, K., Sjölin, S., Bergman, Å., Östman, C. (2001) Flame retardants in indoor air at an electronics recycling plant and at other work environments. *Environ. Sci. Technol.*, **35**: 448–454.
- Sobrado, C., Porro, C., Pérez, P., Aldea, S., Blanco, S. L., Veites, J. M. (2007) PBDEs levels in commercial fishery and aquaculture products from Spain. In Proceedings of the 4th International Workshop on *Brominated Flame Retardants*, Amsterdam, The Netherlands, 24–27 April 2007 (unpaginated).
- Söderström, G., Sellström, U., de Wit, C. A., Tyskling, M. (2004) Photolytic debromination of decabromodiphenyl ether (BDE209). *Environ. Sci. Technol.*, **38**: 127–132.
- Spiegelstein, M. (2007) Industry perspective on brominated flame retardants – an overview. In Proceedings of the 4th International Workshop on *Brominated Flame Retardants*, Amsterdam, The Netherlands, 24–27 April 2007 (unpaginated).
- Stapleton, H. M., Alaei, M., Letcher, R. J., Baker, J. E. (2004) Debromination of the flame retardant decabromodiphenyl ether by juvenile carp (*Cyprinus carpio*) following dietary exposure. *Environ. Sci. Technol.*, **38**: 112–119.
- Stapleton, H. M., Harner, T., Shoeib, M., Keller, J. M., Schantz, M. M., Leigh, S. D., Wise, S. A. (2006) Determination of polybrominated diphenyl ethers in indoor dust standard reference materials. *Anal. Bioanal. Chem.*, **384**: 791–800.
- Stapleton, H. M., Keller, J. M., Schantz, M. M., Kucklick, J. R., Leigh, S. D., Wise, S. A. (2007) Determination of polybrominated diphenyl ethers in environmental standard reference materials. *Anal. Bioanal. Chem.*, **387**: 2365–2379.
- Strandman, T., Koistinen, J., Vartiainen, T. (2000) Polybrominated diphenyl ethers (PBDEs) in placenta and human milk. *Organohal. Cpds*, **47**: 61–64.
- Sudaryanto, A., Kajiwara, N., Tsydenova, O., Iwata, H., Adibrotto, T. A., Yu, H., Chung, K. H., Subramanian, A., Prudente, M., Tana, T. S., Tanabe, S. (2005) Global contamination of PBDEs in human milk from Asia. *Organohal. Cpds*, **67**: 1315–1318.

- Sudaryanto, A., Ramu, K., Isobe, T., Minh, N. H., Agusa, T., Kajiwara, N., Takahashi, S., Iwata, H., Setiawan, I. E., Ilyas, M., Ismail, A., Min, B. Y., Matsumoto, K., Tanabe, S. (2007) Assessment of brominated flame retardants in sediments from Asia: levels, profiles and temporal trends. *Organohal. Cpds*, **69**: 2744–2747.
- Takahashi, S., Isobe, T., Subramanian, A., Takagusa, T., Sakai, S.-L., Tanabe, S. (2007) A review of recent studies on brominated flame retardants in the Asia–Pacific region. In Proceedings of the 4th International Workshop on *Brominated Flame Retardants*, Amsterdam, The Netherlands, 24–27 April 2007, (unpaginated).
- Tanabe, S., Ramu, K., Isobe, T., Kajiwara, N., Takahashi, S., Jefferson, T. A., Yamada, T. K. (2007) Levels and temporal trends of brominated flame retardants (PBDEs and HBCDs) in Asian waters using archived samples from ES-bank, Ehime University, Japan. *Organohal. Cpds*, **69**: 500–503.
- Ter Schure, A. F. H., Larsson, P., Agrell, C., Boon, J. P. (2004) Atmospheric transport of polybrominated diphenyl ethers and polychlorinated biphenyls to the Baltic Sea. *Environ. Sci. Technol.*, **38**: 1282–1287.
- Teuten, E. L., Xu, L., Reddy, C. M. (2005) Two abundant bioaccumulated halogenated compounds are natural products. *Science*, **307**: 917–920.
- Thomsen, C., Knutsen, H. K., Liane, V. H., Frøshaug, M., Kvale, H. E., Haugen, M., Meltzer, H. M., Alexander, J., Becher, G. (2007a) Dietary exposure and serum PBDE concentrations correlate well among consumers of fish from a PBDE contaminated lake. *Organohal. Cpds*, **69**: 770–773.
- Thomsen, C., Molander, P., Daae, H. L., Janák, K., Frøshaug, M., Liane, V. H., Thorud, S., Becher, G., Dybing, E. (2007b) Occupational exposure to hexabromocyclododecane at an industrial plant. *Environ. Sci. Technol.*, **41**: 5210–5216.
- Toms, L.-M. L., Harden, F. A., Symons, R. K., Burniston, D., Fürst, P., Müller, J. F. (2007) Polybrominated diphenyl ethers (PBDEs) in human milk from Australia. *Chemosphere*, **68**: 797–803.
- Toms, L.-M. L., Harden, F., Paepke, O., Ryan, J. J., Hobson, P., Mueller, J. F. (2008) Higher accumulation of polybrominated diphenyl ethers in infants than in adults. *Environ. Sci. Technol.*, **42**(19), 2510–2515.
- Tomy, G., Budakowski, W., Halldorson, T., Alaee, M., MacInnis, G., Marvin, C. (2003) Congener-specific analysis of hexabromocyclododecane (HBCDD) by high-performance liquid chromatography electrospray tandem mass spectrometry. *Organohal. Cpds*, **60**: 448–451.
- Tomy, G., Ismail, N., Pleskach, K., Marvin, C., Whittle, M., Keir, M., Helm, P. (2007) Temporal trends of brominated and chlorinated flame retardants in lake trout (*Salvelinus namaycush*) from Ontario (1979–2004). In Proceedings of the 4th International Workshop on *Brominated Flame Retardants*, Amsterdam, The Netherlands, 24–27 April 2007 (unpaginated).
- Trudel, D., Wormuth, M., Scheringer, M., Hungerbühler, K. (2007) Comparison of total consumer exposure to PBDEs in Europe and North America. In Proceedings of the 4th International Workshop on *Brominated Flame Retardants*, Amsterdam, The Netherlands, 24–27 April 2007 (unpaginated).
- Tsydenova, O. V., Sudaryanto, A., Kajiwara, N., Kunisue, T., Batoev, V. B., Tanabe, S. (2007) Organohalogen compounds in human breast milk from Republic of Buryatia, Russia. *Environ. Pollut.*, **146**: 225–232.
- van den Berg, M. (2007) Some recent developments in BFR toxicology – evidence, arguments and implications for risk assessment. In Proceedings of the 4th International Workshop on *Brominated Flame Retardants*, Amsterdam, The Netherlands, 24–27 April 2007 (unpaginated).
- Wania, F., Dugani, C. B. (2003) Assessing the long-range transport potential of polybrominated diphenyl ethers: a comparison of four multimedia models. *Environ. Toxicol. Chem.*, **22**: 1252–1261.
- Wanner, A., Peichl, L., Köhler, J., Schädel, S., Rupprich, A., Körner, W. (2007) Polybrominated diphenyl ether (PBDE) in Italian ryegrass exposed near to Bavarian shredder plants. In Proceedings of the 4th International Workshop on *Brominated Flame Retardants*, Amsterdam, The Netherlands, 24–27 April 2007 (unpaginated).
- Watanabe, I., Sakai, S. (2003) Environmental release and behaviour of brominated flame retardants. *Environ. Int.*, **29**: 665–682.
- Wilford, B. H., Shoeib, M., Harner, T., Zhu, J., Jones, K. C. (2005) Polybrominated diphenyl ethers in indoor dust in Ottawa, Canada: implications for sources and exposure. *Environ. Sci. Technol.*, **39**: 7027–7035.

- Wong, M. H., Wu, S. C., Deng, W. J., Yu, X. Z., Luo, Q., Leung, A. O. W., Wong, C. S. C., Luksemburg, W. J., Wong, A. S. (2007) Export of toxic chemicals – a review of the case of uncontrolled electronic-waste recycling. *Environ. Pollut.*, **149**: 131–140.
- Zegers, B. N., Lewis, W. A., Booij, K., Smittenberg, R. H., Boer, W., de Boer, J., Boon, J. P. (2003) Levels of polybrominated diphenyl ether flame retardants in sediment cores from western Europe. *Environ. Sci. Technol.*, **37**: 3803–3807.
- Zhu, L. Y., Hites, R. A. (2003) Determination of polybrominated diphenyl ethers in environmental standard reference materials. *Anal. Chem.*, **75**: 6696–6700.

3

Perfluoroalkyl Compounds

*Naomi L. Stock*¹, Derek C. G. Muir² and Scott Mabury¹*

**Currently at Worsfold Water Quality Centre, Trent University, Peterborough,
Ontario, Canada*

¹Department of Chemistry, University of Toronto, Toronto, Ontario, Canada

*²Water Science and Technology Directorate, Environment Canada, Burlington,
Ontario, Canada*

3.1 Introduction and Nomenclature

Perfluoroalkyl compounds (PFCs) consist of a perfluoroalkyl chain (where all hydrogen atoms are replaced with fluorine atoms) and a hydrophilic end group, with the general structure $F(CF_2)_nR$. The perfluoroalkyl chain may be of varying lengths, typically $n = 4$ to 15. Several specific classes of PFCs are discussed below. As research in this field continues and analytical standards and methods evolve, the number of PFCs observed in environmental samples continues to increase.

3.1.1 Polyfluorinated Sulfonamides (FSAs)

Polyfluorinated sulfonamides have the general structure $F(CF_2)_nSO_2NR_1R_2$, where R_1 is typically $-H$, $-CH_3$ or $-CH_2CH_3$ and R_2 is typically $-H$ or $-CH_2CH_2OH$. (Table 3.1) Generally, $n = 4$ or 8 and the resulting FSAs are more specifically described as perfluorobutyl sulfonamides or perfluorooctyl sulfonamides respectively. When R_2 is $-CH_2CH_2OH$, the FSA is also referred to as a polyfluorinated sulfonamidoethanol.

3.1.2 Fluorotelomer Alcohols (FTOHs)

The general structure of fluorotelomer alcohols is $F(CF_2)_nCH_2CH_2OH$, where usually $n = 4, 6, 8, 10$ or 12 (Table 3.1). FTOHs are named based on the ratio of fluorinated carbons to

Table 3.1 *Perfluoroalkyl chemicals of interest, including chemical structures and abbreviations*

Class	Compound	Abbreviation	Formula
Polyfluorinated sulfonamides (FSAs)	<i>N</i> -methyl perfluorobutane sulfonamidoethanol	NMeFBSE	$F(CF_2)_4SO_2N(CH_3)CH_2CH_2OH$
	<i>N</i> -ethyl perfluorobutane sulfonamidoethanol	NEtFBSE	$F(CF_2)_4SO_2N(CH_2CH_3)CH_2CH_2OH$
	Perfluorooctane sulfonamide	PFOSA	$F(CF_2)_8SO_2NH_2$
	<i>N</i> -methyl perfluorooctane sulfonamide	NMeFOSA	$F(CF_2)_8SO_2N(CH_3)H$
	<i>N</i> -ethyl perfluorooctane sulfonamide	NEtFOSA	$F(CF_2)_8SO_2N(CH_2CH_3)H$
	<i>N</i> -methyl perfluorooctane sulfonamidoethanol	NMeFOSE	$F(CF_2)_8SO_2N(CH_3)CH_2CH_2OH$
	<i>N</i> -ethyl perfluorooctane sulfonamidoethanol	NEtFOSE	$F(CF_2)_8SO_2N(CH_2CH_3)CH_2CH_2OH$
Fluorotelomer Alcohols (FTOHs)	4 : 2 fluorotelomer alcohol	4 : 2 FTOH	$F(CF_2)_4CH_2CH_2OH$
	6 : 2 fluorotelomer alcohol	6 : 2 FTOH	$F(CF_2)_6CH_2CH_2OH$
	8 : 2 fluorotelomer alcohol	8 : 2 FTOH	$F(CF_2)_8CH_2CH_2OH$
	10 : 2 fluorotelomer alcohol	10 : 2 FTOH	$F(CF_2)_{10}CH_2CH_2OH$
	12 : 2 fluorotelomer alcohol	12 : 2 FTOH	$F(CF_2)_{12}CH_2CH_2OH$
Perfluoro-sulfonates (PFSAs)	Perfluorobutane sulfonate	PFBS	$F(CF_2)_4SO_3^-$
	Perfluorohexane sulfonate	PFHxS	$F(CF_2)_6SO_3^-$
	Perfluorooctane sulfonate	PFOS	$F(CF_2)_8SO_3^-$
	Perfluorodecane sulfonate	PFDS	$F(CF_2)_{10}SO_3^-$
Perfluoro-carboxylates (PFCAs)	Perfluorohexanoate	PFHxA	$F(CF_2)_5CO_2^-$
	Perfluoroheptanoate	PFHpA	$F(CF_2)_6CO_2^-$
	Perfluorooctanoate	PFOA	$F(CF_2)_7CO_2^-$
	Perfluorononanoate	PFNA	$F(CF_2)_8CO_2^-$
	Perfluorodecanoate	PFDA	$F(CF_2)_9CO_2^-$
	Perfluoroundecanoate	PFUA	$F(CF_2)_{10}CO_2^-$
	Perfluorododecanoate	PFDoA	$F(CF_2)_{11}CO_2^-$
	Perfluorotridecanoate	PFTriA	$F(CF_2)_{12}CO_2^-$
	Perfluorotetradecanoate	PFTetA	$F(CF_2)_{13}CO_2^-$
	Perfluoropentadecanoate	PFPA	$F(CF_2)_{14}CO_2^-$
Perfluorohexadecanoate	PFHxDA	$F(CF_2)_{15}CO_2^-$	
Fluorotelomer carboxylates (FTCAs, FTUCAs)	6 : 2 fluorotelomer carboxylate	6 : 2 FTCA	$F(CF_2)_6CH_2CO_2^-$
	6 : 2 fluorotelomer unsaturated carboxylate	6 : 2 FTUCA	$F(CF_2)_6CHCO_2^-$
	8 : 2 fluorotelomer carboxylate	8 : 2 FTCA	$F(CF_2)_8CH_2CO_2^-$
	8 : 2 fluorotelomer unsaturated carboxylate	8 : 2 FTUCA	$F(CF_2)_8CHCO_2^-$
	10 : 2 fluorotelomer carboxylate	10 : 2 FTCA	$F(CF_2)_{10}CH_2CO_2^-$
	10 : 2 fluorotelomer unsaturated carboxylate	10 : 2 FTUCA	$F(CF_2)_{10}CHCO_2^-$
Fluorotelomer sulfonates (FTSs)	6 : 2 fluorotelomer sulfonate	6 : 2 FTS THPFOS	$F(CF_2)_6CH_2CH_2SO_3^-$
	8 : 2 fluorotelomer sulfonate	8 : 2 FTS	$F(CF_2)_8CH_2CH_2SO_3^-$
	10 : 2 fluorotelomer sulfonate	10 : 2 FTS	$F(CF_2)_{10}CH_2CH_2SO_3^-$

hydrogenated carbons in the molecule. For example, when $n = 4$, the resulting compound is referred to as the 4 : 2 FTOH.

3.1.3 Perfluoroalkylsulfonic Acids/Perfluoroalkylsulfonates (PFSAs)

Perfluoroalkylsulfonic acids have the general structure $F(CF_2)_nSO_3H$, where typically $n = 4, 6, 8$ or 10 (Table 3.1). The most common PFSA is perfluorooctanesulfonic acid (PFOS, $n = 8$). Given the small pK_a values of these compounds, approximately -12 [1], PFSAs dissociate completely in the environment:



As such, when considering this class of compound as environmental contaminants, they are referred to as the perfluoroalkylsulfonates. It is also important to note the PFSAs are anionic surfactants.

3.1.4 Perfluorocarboxylic Acids/Perfluorocarboxylates (PFCAs)

The general structure of perfluorocarboxylic acids is $F(CF_2)_xCOOH$. Generally, PFCAs consist of 6 to 16 carbon atoms, where $x = 5$ to 15 (Table 3.1). Within this group of PFCAs, the most common is perfluorooctane carboxylic acid (PFOA, 8 carbon atoms). It should be noted, however, that trifluoroacetic acid (TFA, 1 carbon atom) is also a common and well-studied PFCA [2, 3]. Similar to the PFSAs, the PFCAs also have small pK_a values, typically 2–3 [4, 5] and are dissociated at environmental pH values:

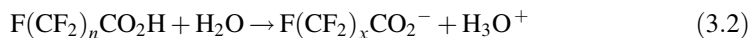

As such, when considering this class of compounds as environmental contaminants, they are referred to as the perfluorocarboxylates. Some authors prefer to remove the A from the acronyms of individual PFCAs (i.e. PFO instead of PFOA) to indicate the anion, but in this discussion acronyms of individual PFCAs are used interchangeably to refer to both the anion and free acid forms. Like the PFSAs, PFCAs are also anionic surfactants.

3.1.5 Fluorotelomer Carboxylic Acids/Fluorotelomer Carboxylates

The fluorotelomer carboxylic acids (FTCAs) and fluorotelomer unsaturated carboxylic acids (FTUCAs) are degradation products of FTOHs with the general structure $F(CF_2)_nCH_2CHOOH$ and $F(CF_2)_nCHCOOH$ respectively, where usually $n = 6, 8$ or 10 (Table 3.1). Similar to FTOHs, FTCAs and FTUCAs are also named based on the ratio of fluorinated carbons to hydrogenated carbons in the molecule. Although the acid dissociation constants are not known for the FTCAs and the FTUCAs, it is assumed they will also dissociate in the natural environment:

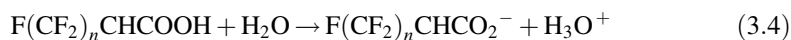
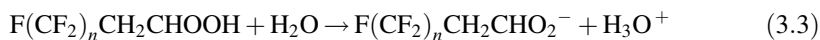

Similarly to the PFSA and PFCAs, when considering this class of compound as environmental contaminants, they are referred to as the fluorotelomer carboxylates and fluorotelomer unsaturated carboxylates.

3.1.6 Fluorotelomer Sulfonic Acids/Fluorotelomer Sulfonates

Fluorotelomer sulfonic acids have the general structure $F(CF_2)_nCH_2CH_2SO_3H$, where usually $n = 6, 8$ or 10 (Table 3.1). Similar to FTCAs/FTUCAs, FTSs are also named based on the ratio of fluorinated carbons to hydrogenated carbons in the molecule. The 6:2 FTS is also known by the abbreviation of THPFOS. Similar to PFSA, it is expected that FTSs will dissociate in the environment:

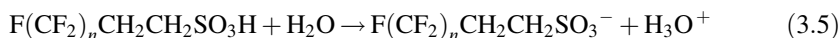

As such, when considering this class of compounds as environmental contaminants, they are referred to as the fluorotelomer sulfonates.

3.1.7 Fluorinated Polymers

Many of the PFCs discussed above, especially FSAs and FTOHs, are often building blocks used in the creation of fluorinated polymers. Fluorinated polymers are characterized by a hydrocarbon backbone, from which PFCs are appended, typically using ester, ether, urethane or methacrylate linkages [6, 7]. It is important to note that fluorinated polymers are not the same materials as fluoropolymers (such as polytetrafluoroethylene and polyvinyl fluoride) which are typically characterized by a fluorocarbon backbone [7].

3.1.8 Uses of PFCs

PFCs, mainly in the form of fluorinated polymers, have been integrated into many known industrial and consumer applications ranging from water-, soil- and stain-resistant coatings for clothing fabrics, leather, upholstery and carpets, oil-resistant coatings for paper products, electroplating and electronic etching bath surfactants, photographic emulsifiers, aviation hydraulic fluids, fire fighting foams, lubricants, paints, adhesives, floor polishes and insecticide formulations [4, 6, 8]. In addition, PFOA and other PFCAs are used as processing aids in the production of polytetrafluoroethylene, and other fluoropolymers [7].

3.2 Manufacturing and Production

Two main processes are used for the commercial manufacturing of PFCs, electrochemical fluorination and telomerization.

3.2.1 Electrochemical Fluorination

Electrochemical fluorination (ECF) was invented by Simons [9] and involves the replacement of all hydrogen atoms in a hydrocarbon with fluorine, in the presence of hydrogen

fluoride (HF) and an electric current. During the ECF process, hydrogen is liberated at the cathode, while fluorination occurs at the anode:

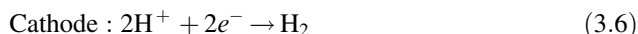

The exact mechanism of fluorination is not completely understood, although both radical and ionic mechanisms have been proposed [4].

ECF can be used for the production of FSAs and both PFSA and PFCAs [4]. Generally, starting materials such as alkanesulfonyl fluoride and alkanecarbonyl fluoride are converted to their perfluorinated counterparts using ECF:

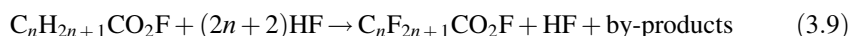
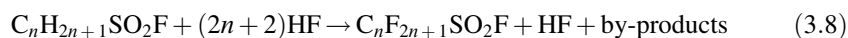

The resulting perfluorosulfonyl fluoride can be converted to the corresponding PFSA by hydrolysis or the FSAs via reaction with amines. Similarly, perfluorocarbonyl fluorides can also be converted, by hydrolysis, to the PFCAs. It is also possible to produce PFSA and PFCAs directly from the ECF of alkanic and alkanesulfonic acids, although yields are generally lower [4]. It is important to note that, due to the aggressive nature of the ECF process, this manufacturing technique results in a mixture of both linear and branched isomers, typically 20–30% and 70–80% respectively, as well as shorter and longer homologue impurities [4].

The ECF process has been used by the 3M Company since around 1947 [4]. Primarily, ECF was used to produce PFOA and a line of perfluorooctane sulfonyl fluoride (PFOSF)-based products including PFOS and perfluorooctyl sulfonamides. However, in 2000, the 3M Company announced that it would be phasing out its line of perfluorooctyl products from 2001 to 2003 [10]. These products have since been replaced by analogous butyl-based substances [11], including the perfluorobutyl sulfonamides produced using the ECF process.

3.2.2 Telomerization

Telomerization is a process that was developed by DuPont [12, 13], and describes a polymerization reaction between a telogen and a taxogen to produce a telomer:

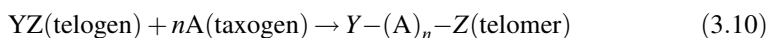

Commercial telomerization usually involves the reaction of pentafluoroethyl iodide (telogen) with tetrafluoroethylene oligomers (taxogen) in the presence of a catalyst, to produce a perfluoroalkyl iodide polymer (telomer):



The resulting perfluoroalkyl iodides do not react with nucleophiles, such as OH^- , to be directly converted into FTOHs or PFCAs [4]. As such, perfluoroalkyl iodides are reacted with ethylene to form perfluoroalkylethyl iodides:



Perfluoroalkylethyl iodides can then be readily converted to the corresponding FTOHs and PFCAs by hydrolysis [4].

It is important to note that materials manufactured using the telomerization process consist of a mixture of compounds varying in carbon chain lengths [4]. In addition, products manufactured using this process reflect the structural arrangement of the starting telogen product and, as such, if a linear starting material is employed, linear products will be produced. The telomerization process is currently being used by several international manufacturers, including Dupont, Daikin Industries Ltd, Asahi Glass Company Ltd, AtoFina and Clariant, for the production of FTOHs, FTSS and/or PFCAs [8].

3.2.3 Production

The 3M Company began production of perfluorooctyl chemicals around 1947 [4, 6]. Production increased in the late 1960s and 1970s as the use of PFSAs and PFCAs as additives in industrial and consumer products became widespread, and PFCs became the choice additives in aqueous fire fighting foams [14]. Production continued to increase throughout the 1980s and 1990s; maximum production was reached in 2000 [15], just prior to the announcement of the phase-out of the perfluorooctyl chemistry by the 3M Company. At that time, the 3M Company was the dominant global manufacturer of PFOS- and PFOA-related chemicals. According to the 3M Company [15], the global production of PFOSF in 2000 was estimated at approximately 3535 metric tonnes, and decreased to an estimated 175 metric tonnes worldwide in 2001. PFOA-, PFOS- and PFOSF-based products were completely phased out by the 3M Company by 31 December 2002 [16]. As such, it is believed that the majority of the global PFOA production at this time is via the telomerization method. Currently, the 3M Company is producing perfluorobutyl-based products, although production volumes of the perfluorobutyl sulfonamides are unknown.

FTOH-based products have been manufactured since the 1970s [14]. Global production of FTOHs from 2000 to 2002 was estimated at 5000 to 6500 metric tonnes per year [17]. Since that time, FTOH production has increased approximately twofold, to an estimated 12 000 metric tonnes per year in 2004, representing sales of approximately \$700 million annually [18]. Current production levels of FTOHs are unavailable, but are assumed to be comparable to or greater than 2004 estimates.

A recent survey by the Organization for Economic Co-operation and Development (OECD), has investigated production of PFSAs, PFCAs and products or mixtures containing PFSAs and PFCAs [19]. Caution is advised that results from this survey may overestimate actual production values. Results indicated that in 2005, 74 to 175 metric tonnes of PFOS- and PFOS-containing products were manufactured and/or imported, of which up to 90 metric tonnes were PFOSF. These production volumes were less than the

3000 metric tonnes reported in 2003 [19] and are consistent with the phase-out of PFOSF-based chemistry by the 3M Company. These results are also consistent with the observation by the US Environmental Protection Agency that manufacture of PFOS for certain uses for which no substitutes are available are continuing by non-US producers [20]. Manufacturing and/or importing volumes of PFSA and PFSA-based products ($n = 4$ to 10) in 2005 were 91–222 metric tonnes and had significantly decreased from volumes (up to 6000 metric tonnes) reported in 2003 [19]. However, PFBS-based products showed a marked increase during this period and represented the majority of PFSA and PFSA-based products, indicating that PFBS-based chemicals are replacing PFSA and PFCA products [19].

Production of PFOA and other PFCAs were also investigated in the OECD investigation [19]. Results of the survey indicate that in 2005, 69 to 320 metric tonnes of PFOA and PFOA-containing products were manufactured and/or imported. It is interesting to note that PFOA in both the linear form and as mixtures of linear and branched forms was indicated, as was the presence of PFOA as an impurity in other products and mixtures. Manufacturing and/or importing volumes of PFOA and PFOA-containing products in 2005 was significantly less than in 2003, when quantities of up to 2000 metric tonnes were reported [19]. The largest manufacturing and/or importing volumes were reported for PFCAs and PFCA-containing products, with 771 to 7273 metric tonnes reported in 2005. The majority of products reported in this category were mixtures of PFCAs ($n = 4, 6, 8, 10, 12, 14$ and 16).

It is also interesting to note that over 350 fluorinated compounds, many of which are PFCs, are found on the United States Environmental Protection Agency's Toxic Substances Control Act (TSCA) Chemical Inventory. Of these, at least 80 fluorinated compounds were identified with production or import greater than 4.5 metric tonnes in 2002 [21].

3.3 Overview of Toxicology

3.3.1 Toxicology of PFSA and PFCAs

There has been considerable interest over the past two decades to investigate the toxicological affects of PFSA and PFCAs. In particular, the toxicology of PFOS and PFOA has been well studied and reviewed by Lau *et al.* [22, 23] and Kennedy *et al.* [24].

The pharmacokinetics of PFOS and PFOA have been investigated in animal studies [22–24]. Results indicate that both PFCs are well absorbed following oral exposure, and poorly eliminated. In addition, PFOS and PFOA are very persistent as they are not metabolized and undergo extensive enterohepatic circulation [25, 26]. PFSA and PFCAs are unique among other persistent halogenated organic contaminants as they do not preferentially accumulate in fatty tissues, but instead are predominately distributed in the liver, serum and kidney [22–24]. This may be explained by the fact that PFOS and PFOA bind to proteins, specifically β -lipoproteins, albumin and liver fatty acid-binding proteins [27, 28].

In general, the rate of elimination of PFCAs and PFSA decreases with increasing length of the perfluoroalkyl tail [23]. Differences in elimination of PFSA and PFCAs have been

observed between species and between genders of a single species [22–24]. For example, the half-life of PFOS ranges from 100 days in rats to 5.4 years in humans. In rats, half-lives of PFOA were reported to be < 1 day in females and 15 days for males [29]. Reasons for the observed gender and species differences in elimination rates of PFCs are not completely understood. It has been hypothesized that gender differences in the elimination of PFOA may be as a result of sex hormone-regulated renal transport via an organic anion transporter protein [30].

PFOS, PFOA, PFNA and PFDA have been identified as peroxisome proliferators, also referred to as PPAR agonists [22, 31–34]. In cultured rat hepatocytes, PFCAs with eight or more carbons were observed to be the most potent peroxisome proliferators [34]. Exposure to peroxisome proliferators can result in a variety of toxicological effects including increased β -oxidation of fatty acids, often resulting in an accumulation of lipids in the liver [31–33], inhibition of the secretion of very low-density lipoproteins and cholesterol from the liver [24] and induction of xenobiotic metabolizing enzymes such as the cytochrome P450 enzymes [35]. Peroxisome proliferating PFCs have also been reported to induce nongenotoxic hepatic carcinomas in mammals [36].

PFASs and PFCAs have also been found to inhibit gap junction intercellular communication (GJIC) in both *in vitro* and *in vivo* studies [37, 38]. GJIC is the major pathway of intercellular signal transduction and is important for normal cell growth and function. GJIC inhibition has been implicated as a mechanism for hepatic carcinogenicity [37] and appears to be on the length of the perfluoroalkyl tail. For example, PFCAs with 7 to 10 carbons in the perfluoroalkyl tail were observed to inhibit GJIC in a dose-response fashion, whereas no inhibition was observed for PFCAs with 2 to 5 carbons [37]. Similarly, inhibition was observed with PFOS and PFHS, but not PFBS [38].

The chronic toxicity of PFOA has been investigated in a number of animal studies [24]. Typically, tumours are observed in liver cells, Leydig cells (testis) and pancreatic cells [24]. As discussed above, both peroxisome proliferation and inhibition of GJIC can result in tumour growth. An advisory panel to the US Environmental Protection Agency has proposed that PFOA be deemed a rodent carcinogen with relevance to humans [39].

3.3.2 Toxicology of FTOHs and FSAs

As will be discussed in further detail below, FTOHs and FSAs can undergo biological degradation to form PFCAs or PFASs respectively. As a result, most toxicological studies investigate the hazardous effects of the PFCAs or PFASs themselves, although a limited number of studies have investigated the toxicity of FSAs and FTOHs.

The 8:2 FTOH, similar to PFOS and PFOA, has also been identified as a peroxisome proliferator [40], and capable of inducing enzymatic activity in the liver and altering hepatic metabolism. In a recent study [41], interaction between the 6:2 and 8:2 FTOHs and human estrogen receptors was also observed, indicating possible estrogenic effects of the FTOHs.

FSAs such as PFOSA have been observed to inhibit GJIC [38]. In a study by Case, York and Christian [42], NEtFOSE was observed to exhibit development toxicity in mammals and it was generally observed that profiles of developmental toxicity were similar to that of

PFOS [22]. Unlike PFOS, NEtFOSE has shown no activity as a peroxisome proliferator [43]. It is likely that the toxicological effects of NMeFOSE would be similar to those observed for NEtFOSE.

3.3.3 Toxicology of FTCAs/FTUCAs

Very little research has focused on the toxicity of FTCAs or FTUCAs. A study by Phillips *et al.* [44] assessed the acute toxicity of the 4:2, 6:2, 8:2 and 10:2 FTCAs and FTUCAs to three common freshwater organisms: *Daphnia magna*, *Chironomus tentans* and *Lemna gibba*. In general, toxicity was found to increase with increasing perfluoroalkyl chain length and the FTCAs were more toxic than the corresponding FTUCAs. This study also provided evidence that the FTCAs/FTUCAs are more toxic than PFCAs [44].

3.4 Physical Chemical Properties and Environmental Fate

3.4.1 The Influence of Fluorine

The commercial popularity of PFCs is primarily due to their unique physical and chemical properties, such as thermal stability, resistance to chemical degradation, repellency to water and oils, and low surface tensions [4]. Many of these properties arise because of the unique properties of fluorine [45].

Fluorine is the most electronegative element and attracts electrons towards itself [46]. As such, fluorine has both a high ionization potential and very low polarizability [4, 47]. The large difference in electronegativity between carbon and fluorine atoms results in a strong polarization of the carbon–fluorine bond. The carbon–fluorine bond is the strongest observed in organic chemistry (~ 484 kJ/mole), and strength of the bond increases with the number of fluorine substituents bound to the carbon atom. For example, in terminal CF_3 groups, strength of the carbon–fluorine bond has been reported to be as high as 531 kJ/mole [48]. The main reason for this is the nearly optimum overlap between the 2s and 2p orbitals of the fluorine atoms and the corresponding orbitals of carbon [49]. The unusual strength of the carbon–fluorine bond contributes to the thermal and chemical stability of poly- and perfluorinated chemicals [7, 45].

Although fluorine atoms are small, they are significantly larger than hydrogen atoms (van der Waal radii of 1.47 and 1.20 Å respectively) [50]. As a result, perfluoroalkyl chains are stiffer, bulkier and more inflexible than their hydrogen counterparts [51]. The fluorine atom has three pairs of nonbonding electrons in its outer electronic shell. In a perfluoroalkyl chain, these nonbonding electrons of the densely packed fluorine atoms act as a ‘sheath’ or ‘coating’ around the carbon backbone. This electron cloud sheath is an effective electrostatic and steric shield against any nucleophilic attack targeted against the central carbon atoms [45, 49] and also contributes to the chemical stability of PFCs.

In contrast to the zigzag formation of linear hydrocarbons, long perfluoroalkyl chains are helical, rigid and rod-like structures [49, 52]. This structure, due to the steric repulsion between fluorine atoms, consists of a full helical twist every 13 carbon atoms [49, 52]. Short

perfluorinated chains are thought to have a zigzag conformation similar to their hydrocarbon analogues, but an increasing amount of helical character is typically observed with each additional CF_2 segment [53]. Furthermore, a distinct change in geometry to the helical form is consistently observed, when the perfluorinated chain exceeds eight carbons in length [53–55]. Chain rigidity has also been shown to be a function of the length of the perfluoroalkyl chain [54].

Depending on the hydrophilic end group of the PFC, hydrogen bonding between the end group and the perfluoroalkyl chain can occur [53, 56–60]. For example, in the FTOHs, an intramolecular hydrogen bond can exist between the hydroxylic proton and the two fluorine atoms next to the ethanol moiety ($-\text{O}-\text{H}\cdots\text{F}-$) [58, 59]. A similar intramolecular hydrogen bond can also exist in NMeFOSE and NEtFOSE [61]. This intramolecular hydrogen bonding influences the geometry of the molecule and, as such, may also influence physical properties such as vapour pressure and octanol–water or octanol–air partitioning coefficients [58, 59].

Due to the high ionization potential and low polarizability of fluorine, the perfluoroalkyl chain exhibits weak intermolecular interactions that are reflected in extremely low surface tension values [49]. As such, ideal surfactants can be created when a hydrophilic functional group, such as SO_3^- and CO_2^- , used to form the PFSA and PFCAs respectively, is attached to a perfluoroalkyl chain [4]. Interestingly, when PFSA and PFCAs are mixed with water and hydrocarbons, three immiscible phases are formed. In addition to the aqueous and organic phases, a fluoros phase is also present and is indicative of both the hydrophobic and oleophobic nature of some PFCs [49]. Similarly, highly fluorinated chemicals, such as the PFCs, show greatest solubility in highly fluorinated solvents, a phenomenon known as fluorophicity [62].

As discussed previously, both PFSA and PFCAs have small acid dissociation constants [1, 4, 5] and are dissociated at environmental pH values. It is important to note that the dissociated and free acid forms of the PFSA and PFCAs have different physical–chemical properties and environmental partitioning properties. In addition, physical–chemical properties may also differ between various salts of PFSA and PFCAs, depending on the counter ion present [63].

3.4.2 Water Solubility

Several studies have measured the water solubility of FSAs and FTOHs (Table 3.2). Measured values for the water solubility of the 8:2 FTOH, at 25 °C, range from 137 ng/L [64] to 194 ng/L [65]. A water solubility of 105 ng/L, at 25 °C, has been reported for NEtFOSE [66].

Water solubility values of PFSA and PFCAs have also been determined (Table 3.2). It should be noted that in the literature these experiments often indicate measurement of the water solubility of the free acid, but since PFSA and PFCAs completely dissociate in water, these measurements are in fact for the dissociated species. (To determine the aqueous solubility of the free acid species, experiments would need to be conducted in acidic solutions.) Water solubility of PFOA has been determined in several studies, with reported values ranging from 4.1 g/L at 22 °C [67] to 3.4 g/L [68] and 9.5 g/L at 25 °C [69]. The aqueous solubility of PFDA has been reported as 5.1 g/L at 25 °C [69]. To date, measurements of the water solubility of other PFCAs are not available, but it is known that

Table 3.2 Physical chemical properties of PFCs. No physical chemical property data is available for FTCAs/FTUCAs and FTSs. Calculated values are indicated with an *

	FTOHs	FSAs	PFSAs	PFCAs
Water solubility (25 °C)	8:2 FTOH 137 ng/L [64] 194 ng/L [65]	NEtFOSE 105 ng/L [66]	PFOS 570 mg/L [70]	PFOA 4.1 g/L (22 °C) [67] 3.4 g/L [68] 9.5 g/L [69] PFDA 5.1 g/L [69]
Vapour pressure (Pa, 25 °C)	4:2 FTOH 992 [59] 1670 [71] 216 [72] 6:2 FTOH 713 [59] 876 [71] 44 [72] 18 [72] 8:2 FTOH 254 [59] 227 [71] 7 [64, 72] 4 [72] 31 [73] 10:2 FTOH 144 [59] 53 [71] 0.2 [72]	NEtFOSA 7.0 [71] NMeFOSE 0.7 [71] 2.0 × 10 ⁻³ [74] NEtFOSE 0.35 [71] 8.6 × 10 ⁻³ [74] 0.792 [75]	PFOS 3.31 × 10 ⁻⁴ (20 °C) [70]	PFOA 4.19 [76] PFNA 1.27 [76] PFDA 0.229 [76] PFUnA 0.105 [76] PFDoA 8.03 × 10 ⁻³ [76]
Henry's law constant (log K _{AW} , 25 °C)	4:2 FTOH 1.83 [71] -1.52 [71] 6:2 FTOH 1.66 [71] -0.56 [77] 8:2 FTOH 1.31 [71] 0.53 [77] 0.58* [77]	Not available	Not available	PFOA -2.99 [78]
Sorption (log K _{OC})	8:2 FTOH 4.13 [65]	Not available	PFOS 2.2 [79] 2.57 [80] PFDS 3.53 [80]	PFOA 0.99 [79] 2.06 [80] PFNA 2.39 [80] PFDA 3.4 [79] 2.76 [80] PFUnA 3.30 [80]

(continued)

Table 3.2 (Continued)

	FTOHs	FSAs	PFSAs	PFCAs
Bioaccumulation (log BAF or log BCF (L/kg))	Not available	PFOSA 3.8 (log BAF)[82]	PFHxS 2.7 (log BAF) [82] PFOS 4.1 (log BAF) [82] 3.04 (log BCF) [84] 5.10 (log BAF) [85] 3.9 (log BAF) [86]	PFOA 3.1 (log BAF) [82] 0.602 (log BCF) [84] PFDA 3.9 (log BAF) [82] 2.65 (log BCF) [84] PFUnA 3.43 (log BCF) [84] PFDoA 4.26 (log BCF) [84] PFTetA 4.36 (log BCF) [84]
Octanol–air partitioning coefficient (log K_{OA})	4:2 FTOH 3.26 [71] 4.80 [77] 6:2 FTOH 3.56 [71] 5.26 [77] 8:2 FTOH 4.17 [71] 5.56 [77] 10:2 FTOH 4.83 [71]	NEtFOSA 5.86 [71] NMeFOSE 6.78 [71] 7.70 [74] NEtFOSE 7.09 [71] 7.78 [74]	Not appropriate	Not appropriate
Octanol–water partitioning coefficient (log K_{OW})	4:2 FTOH 1.97 [66] 2.31* [61] 6:2 FTOH 3.30 [66] 3.32* [61] 8:2 FTOH 4.88 [66] 4.31* [61] 10:2 FTOH 2.91 [66] 4.35* [61]	PFOSA 4.08 [66] 4.35* [61] NEtFOSA 4.51 [66] 5.49* [61] NEtFOSE 5.33 [66] 5.39* [61]	Not appropriate	Not appropriate

water solubility of PFCAs decreases with increasing length of the perfluoroalkyl chain [7]. Water solubility of PFOS has been determined to be 570 mg/L [70], indicating that PFOS is approximately an order of magnitude less water soluble than PFOA. Although water solubility measurements of other PFSAs are not currently available, it is assumed that, similar to the PFCAs, water solubility of the PFSAs would also decrease with increasing length of the perfluoroalkyl chain. Water solubility values of the free acid forms of the

PFSAs and PFCAs are assumed to be negligible. Water solubility values have also not yet been determined for the FTCAs and FTUCAs.

It should be noted that as both PFSAs and PFCAs are surfactants, water solubility increases abruptly when the critical micelle concentration (CMC) is reached. CMC is the concentration at which equilibrium of singly dispersed molecules and molecules in aggregated or the micelle form is reached. CMC values of PFOS and PFOA are approximately 4 and 3.6 to 4 g/L respectively [4].

3.4.3 Vapour Pressure

Several studies have measured vapour pressures of the FTOHs [59, 64, 71–73] (Table 3.2); however, reported values are variable, differing by several orders of magnitude. Vapour pressures of the FTOHs are influenced by the length of the perfluoroalkyl chain, and increase as length of the perfluoroalkyl chain decreases. Reported vapour pressures of the FTOHs, at 25 °C, range from minimum values of 0.2 Pa (10:2 FTOH) to 216 Pa (4:2 FTOH) reported by Krusic *et al.* [72] to maximum values of 53 Pa (10:2 FTOH) to 1670 Pa (4:2 FTOH) reported by Lei *et al.* [71].

Two studies [71, 74] in the peer-reviewed literature have investigated the vapour pressures of the FSAs (Table 3.2). Similar to the FTOHs, reported values are variable, differing by several orders of magnitude. The vapour pressure of NETFOSE has also been determined by the 3M Company [75]. It is possible that some of the difficulties encountered in measuring vapour pressures of the FTOHs are also applicable to the FSAs.

Vapour pressures of the free acid forms of PFCAs have also been determined and values vary by several orders of magnitude (Table 3.2). Kaiser *et al.* [76] measured the vapour pressures of PFCAs and extrapolated values at 25 °C, which range from 4.19 Pa (PFOA) to 8.03×10^{-3} Pa (PFDoA). The vapour pressure of the free acid form of PFOS, at 20 °C, has been reported as 3.31×10^{-4} Pa [70]. Vapour pressures of the dissociated forms of the PFSAs and PFCAs have not been determined and are expected to be much less.

3.4.4 Henry's Law Constants

Henry's law constants, also known as air–water partitioning coefficients (K_{AW}), have been measured for the FTOHs in two studies (Table 3.2). Lei *et al.* [71], reported $\log K_{AW}$ values that were all of a similar order of magnitude. The $\log K_{AW}$ values reported by Goss *et al.* [77] were much less than those reported by Lei *et al.* [71] and generally increased with increasing length of the perfluoroalkyl tail. To date, measured $\log K_{AW}$ values have not been reported for the FSAs.

Calculated Henry's law constants, using the ratio of vapour pressure and water solubility, can also be determined (Table 3.2). Using vapour pressure and water solubility values presented above, a calculated $\log K_{AW}$ value of 0.58 for the 8:2 FTOH was suggested by Goss *et al.* [77] to be more accurate than their measured $\log K_{AW}$ value, due to difficulties with adsorption of the 8:2 FTOH in the experimental setup.

An experimentally determined K_{AW} value of 1.02×10^{-3} ($\log K_{AW}$ value of -2.99) at 25 °C has been reported for the free acid form of PFOA by Li, Ellis and Mackay [78] (Table 3.2). Measured Henry's law constants for other PFCAs, PFSAs, FTCAs and FTUCAs

are not available in the peer-reviewed literature. Some calculated Henry's law constants for PFSA and PFCAs have also been presented, but, given the lack of physical property data available, the vapour pressure and water solubility values used have not been for the same chemical species. Generally for PFSA and PFCAs, it is expected that Henry's law constants for the free acid species will be high, while Henry's law constants for the dissociated species are negligible [14]. As such, any volatilization that might occur is likely to be of the free acid species.

It is generally accepted that in the natural environment FSAs and FTOHs are predominately in the gas phase, while PFSA, PFCAs, FTCA and FTUCA are more predominant in the aquatic phase.

3.4.5 Sorption

It is well established in the literature that PFCs have a tendency to adsorb to a variety of surfaces, including laboratory glassware and equipment [61, 64, 77]. As such, it is not surprising that PFCs are generally expected to exhibit sorption in the natural environment. The sorptive abilities of FTOHs have been measured in two studies (Table 3.2). Liu and Lee [65] investigated the sorption of the 8:2 FTOH to five soils, with a range of properties, and determined a soil organic carbon normalized distribution coefficient ($\log K_{OC}$) value of 4.13. Arp, Niederer and Goss [61] measured adsorption coefficients ($K_{surf/air}$), at 15 °C, of the 4:2, 6:2 and 8:2 FTOHs on three surfaces of quartz, Al_2O_3 and $CaCO_3$. These surfaces were suggested as laboratory surrogates for natural surfaces such as minerals, salts, soot, water droplets and snow. $K_{surf/air}$ values ranged from 3.82×10^{-3} (4:2 FTOH on quartz) to 4.22×10^{-1} (8:2 FTOH on Al_2O_3) and were observed to increase with increasing length of the perfluoroalkyl chain. No studies investigating the sorption of FSAs are currently available in the peer-reviewed literature.

The sorption of PFSA and PFCAs to soils has been investigated in two studies (Table 3.2). Sullivan and Mabury reported soil $\log K_{OC}$ values for PFOS, PFOA and PFDA of 2.2, 0.99 and 3.4 respectively [79]. These values were generally consistent with those reported by Higgins and Luthy [80]. In this study, sediment $\log K_{OC}$ values for PFOS and PFDS were 2.57 and 3.53 respectively, while sediment $\log K_{OC}$ values for a suite of PFCAs ($n = 8$ to 11) ranged from 2.06 to 3.30. Increasing sorption of PFSA and PFCAs to sediment with increasing length of the perfluoroalkyl chain was observed, with each additional CF_2 moiety contributing 0.50 to 0.60 log units. In addition, the average sorption of PFSA was 1.7 times (0.23 log units) stronger than that observed for the corresponding PFCa analogue [80]. To date, the sorption of FTCA and FTUCA has not yet been investigated.

3.4.6 Bioaccumulation

There have been limited studies investigating the bioaccumulation of FSAs and FTOHs (Table 3.2). A study [81] on the uptake, transformation and elimination of FTOHs and PFOSA determined that these compounds are rapidly transformed and eliminated in fish. As such, it is unlikely that most FTOHs and FSAs will undergo substantial bioaccumulation. Furdui *et al.* [82] have reported a field-based bioaccumulation factor ($\log BAF$) of 3.8 for PFOSA, based on measured concentrations in Great Lakes waters and whole fish homogenates.

Bioaccumulation studies of PFSA (n = 6 and 8) and PFCA (n = 7, 8, 10, 11 and 13) in rainbow trout (*Oncorhynchus mykiss*) have been conducted by Martin *et al.* [83, 84] (Table 3.2). These studies indicated that dietary exposure to PFSA and PFCA did not result in biomagnification. Bioaccumulation was observed for PFSA and PFCA consisting of more than six and seven carbon atoms respectively. The laboratory-based bioconcentration factor (log BCF) for PFOS was 3.04 L/kg and ranged from 0.602 to 4.36 L/kg for the PFCA. Log BCFs were observed to increase with increasing length of the perfluoroalkyl tail and for the PFCA increased by a factor of approximately 8 for each additional CF₂ moiety for PFCA (n = 8 to 12), but deviated from linearity for PFTetA. In addition, PFSA were more bioaccumulative than PFCA.

Biological monitoring studies also provide strong evidence that PFSA and PFCA can bioaccumulate (Table 3.2). The largest log BAF for PFOS, 5.1, was calculated in fish from Etobicoke Creek following an accidental spill of fire-fighting foam [85], although the authors note that this BAF may have been influenced by the presence of other PFCs in the water, which could metabolize to PFOS. Taniyasu *et al.* [86] reported a mean log BAF for PFOS, calculated using concentrations in water and fish of Japan of 3.9. Furdui *et al.* [82] have reported BAFs for Great Lakes fish. Calculated log BAF values for PFOS and PFHxS were 4.2 and 2.7 respectively, while log BAF values for the PFCA increased with increasing length of the perfluoroalkyl chain, from 3.1 (PFOA) to 3.9 (PFDA).

Biomagnification factors (BMFs) for PFSA and PFCA have also been calculated. For example, Tomy *et al.* [87] reported BMFs for PFOS ranging from 0.4 to 9, indicating that PFOS biomagnifies in the Arctic marine food web. Kannan *et al.* [88] determined PFOS BMFs for bald eagles, mink and Chinook salmon of 5 to 10 based on observed liver concentrations. Houde *et al.* [89] reported BMFs for a suite of PFCs ranging from < 1 to 156 in the food web of the bottlenosed dolphin (*Tursiops truncatus*) and reported biomagnification of PFOS, PFDA, PFUnA and PFDoA in this marine food web.

3.4.7 Other Partitioning Properties

Octanol–air partition coefficients (K_{OA}) have been measured for the FSA [71, 74] and FTOHs [71, 77] (Table 3.2). For the FTOHs, log K_{OA} increases with increasing length of the perfluoroalkyl chain. Lei *et al.* [71] reported measured values ranging from 3.26 (4:2 FTOH) to 4.83 (10:2 FTOH), while Goss *et al.* [77] reported larger values ranging from 4.80 (4:2 FTOH) to 5.56 (8:2 FTOH). Lei *et al.* [71] also measured log K_{OA} values for NEtFOSA, NMeFOSE and NEtFOSE of 5.86, 6.78 and 7.09 respectively. These values are consistent with log K_{OA} values of 7.70 and 7.78 reported for NMeFOSE and NEtFOSE respectively by Shoeib *et al.* [74].

Octanol–water partition coefficients (K_{OW}) have also been measured for the FTOHs and three FSA [66] (Table 3.2). Log K_{OW} values of these PFOSA, NEtFOSA and NEtFOSE were similar, 4.08, 4.51 and 5.33 respectively. For the FTOHs, log K_{OW} values increased with increasing length of the perfluoroalkyl chain from 1.97 (4:2 FTOH) to 4.88 (8:2 FTOH), but deviated from linearity for the 10:2 FTOH (log K_{OW} of 2.91). These measured K_{OW} values are significantly greater than the K_{OW} values calculated by Arp, Niederer and Goss [61], using log K_{OA} and log K_{AW} values, which ranged from 2.31 (4:2 FTOH) to 4.35 (10:2 FTOH).

As PFSA and PFCAs are both hydrophobic and oleophobic, and form multiple layers when mixed with water and hydrocarbons [49], K_{OW} values are not appropriate or relevant for these PFCs [26]. Similarly, other partition coefficients and traditional environmental fate models based on air, water and octanol partitioning are not suitable for PFSA and PFCAs.

3.4.8 Persistence of PFCs in the Environment

As discussed above, FSAs and FTOHs are reactive in the environment, under both abiotic and biological conditions, and can degrade to produce PFSA and/or PFCAs. However, PFSA and PFCAs themselves are extremely persistent in the environment. Many of the unique physical and chemical properties of PFSA and PFCAs that are beneficial from an industrial or commercial point of view are the same properties that result in recalcitrant and persistent environmental contaminants [50]. To date, no degradation of PFSA or PFCAs in environmental conditions, either abiotic or biotic, has been observed [26, 50]. For example, PFCAs were detected in $\mu\text{g/L}$ concentrations in groundwater at two military bases, 7 to 10 years after use [90]. In a 285-day, outdoor microcosm study under natural conditions [91], no reduction in PFOS concentrations were observed, confirming that this chemical undergoes little degradation in aquatic systems. Similarly, no changes in PFOA concentrations in a 35-day outdoor microcosm study were observed for treatment concentrations of 0.3, 1 and 30 mg/L [92].

3.5 Overview of Measurement Techniques

3.5.1 Background Contamination

The most challenging aspect of measuring PFCs in environmental samples is background contamination. In fact, 'contamination at every step of the analysis ... is a common problem' [93]. Sources of this contamination are not completely characterized, but can include sampling, instrumental and analytical/procedural sources. This serves to highlight the importance of field, matrix and reagent blanks [94].

One known source of contamination is contact with laboratory materials made of, or containing, fluoropolymers such as polytetrafluoroethylene. Whenever possible, contact with these materials should be avoided during sampling, extraction and analysis. Sampling containers, filters, solid-phase extraction cartridges and vial caps with fluoropolymer septa have been reported to contain PFC contamination [95]. Internal components of some analytical instruments are also constructed of fluoropolymers, and can result in post-injection contamination during analysis. This contamination can be minimized by replacing fluoropolymer components with stainless steel and polyether-etherketone (PEEK) and/or installing an upstream guard column [94]. Instrumental contamination due to injection-port carryover is also an issue. This can be minimized by the routine analysis of solvent blanks after high-concentration samples or standards [94] and by following the suggested guideline of not exceeding 10 ng of PFCs in an individual injection on a typical mass spectrometer [94]. Impurities in low-grade solvents, reagent water [96] and analytical standards [94, 96] also contribute to the problem of background contamination.

3.5.2 Sampling Techniques

Water, sediment and biological samples are typically collected in polyethylene, polypropylene or polycarbonate sampling containers. Prior to use, sampling containers should be rinsed with a high-grade solvent, typically methanol, and be checked for contamination. There has been some debate on whether ionic PFCs adsorb to glass surfaces [97], so generally glass sampling containers are avoided [94, 96]. Due to the volatility of the neutral PFCs, as will be discussed below, headspace should be avoided. Acidic preservative should not be added to samples to avoid altering the physical chemical properties of the ionic PFCs [97] and possible suppression of analyte signals [98].

Air samples are typically collected using high-volume samplers employing glass or quartz fibre filters for collection of the particulate phase and polyurethane foam (PUF) with or without XAD resin for the gaseous phase [97]. To minimize contamination, air sampling media is cleaned prior to use with high-grade solvents such as methanol, ethyl acetate, acetone and/or dichloromethane [74, 99–102]. Removal of fluoropolymer gaskets from high-volume air samplers to reduce background contamination is also recommended [74, 99, 100].

As will be discussed in more detail below, PFASs and PFCAs are extremely persistent, and therefore degradation of these PFCs will not occur under reasonable storage conditions. Biological degradation of FTOHs to ionic PFCs can occur, however [103, 104], and all samples should be analysed directly after sampling, if possible, and frozen for long-term storage [94, 97].

3.5.3 Extraction and Clean-up Methods

A wide range of extraction and clean-up methodologies have been employed for the measurement of PFCs in environmental and biological matrices, and have been reviewed by van Leeuwen and de Boer [97]. Initially, PFCs were extracted from biological samples employing an ion-pairing method developed by Hansen *et al.* [105]. This method involves a liquid–liquid extraction, employing alkaline conditions and an ion-pairing agent, such as tetrabutyl ammonium hydrogen sulfate, into an organic solvent. Typically the organic solvent of choice is methyl-*tert*-butyl ether. This is followed by complete evaporation and subsequent reconstitution of the extract into a solvent suitable for instrumental analysis. Modifications of the ion-pairing method developed by Hansen *et al.* [105] have been reported for a large variety of biological samples including mammalian liver [106, 107], fish and bird eggs [106], blood [108], whole fish homogenates [82, 109] and invertebrates [109].

New methods have been introduced for the extraction and clean-up of PFCs in both biological and environmental samples. Primarily these methods have focused on solid phase extraction (SPE) for fluid samples, and accelerated liquid extraction or liquid–solid extraction methods for solid samples [97]. The extraction media of choice is dependent on the polarity of the PFCs to be analysed. Typically, moderately polar media such as Oasis WAX SPE or methanol and acetonitrile are employed for extraction of shorter chain (C_4 to C_6) PFASs and PFCAs, while less polar or nonpolar SPE media such as C_{18} and Oasis HLB are employed for the longer chain PFASs and PFCAs [97]. Neutral PFCs have been extracted using both nonpolar media such as C_{18} SPE or hexane and moderate polar such as Oasis HLB and WAX SPE, a hexane–acetone mixture or acetonitrile [97].

Following extraction, clean-up of the raw extract is generally recommended prior to analytical analysis. This is particularly important when employing nonpolar extraction solvents, such as MTBE, that co-extract lipids from biological matrices which may interfere with the instrumental analysis. Current clean-up methods for biological samples include silica column fractionation, sulfuric acid treatment and dispersive carbon clean-up [97]. C₁₈ SPE and graphitized carbon are typically employed for the clean-up of sediment, soils and sludge extracts [97]. Care should be taken during the clean-up procedure to avoid loss of PFCs and contamination of the extract.

Water samples are generally extracted using SPE, using a modification of the method developed by Hansen *et al.* [110] and employing a variety of SPE media, as discussed above, depending on the class of PFCs to be analysed [96, 111]. Care to avoid contamination is required at all steps in the extraction process to enable the lower detection limits (ng/L and pg/L) often required for measurements of PFCs in aqueous samples [112]. Direct injection methods have also been developed for a variety of aqueous samples, including groundwater [98], snow [113] and surface waters [114]. These methods are advantageous as possible contamination during the extraction and clean-up steps is avoided and laboratory preparation time is reduced.

Air sampling media has been extracted using different solvent systems. Both particulate and gas phase extracts have been extracted using methanol/ethyl acetate [99, 100, 102], while other studies have employed petroleum ether/acetone for extraction of the PUF/XAD and dichloromethane for the filter [101]. Generally extracts are filtered prior to analysis. Some researchers have also included a clean-up step. For example, Shoeib, Harner and Vlahos [101] passed PUF/XAD sample extracts through an alumina column and eluted with dichloromethane in ethyl acetate, prior to the analysis of FTOHs and FSAs.

3.5.4 Analysis via Liquid Chromatography–Tandem Mass Spectrometry

Liquid chromatography combined with tandem mass spectrometry (LC-MS/MS) is the analytical technique of choice for measurement of ionic PFCs in environmental samples. Recent reviews on the use of this technique for the analysis of PFCs have been published by de Voogt and Saez [111] and Villigrasa, Lopez de Alda and Barcelo [96].

Reverse phase liquid chromatography has typically been used for the separation of PFCs, employing either C₈ or C₁₈ columns [96], although the use of perfluoroalkyl columns has also been reported [115]. Mobile phases are typically mixtures of methanol–water or acetonitrile–water and are often modified with ammonium acetate to improve chromatographic separation and MS sensitivity. Both isocratic and gradient elution methodologies have been employed [96]. LC-MS/MS methods [116, 117] have also been developed for the separation of PFSA and PFCA isomers and generally employ linear perfluorooctyl stationary phases and acidified mobile phases.

Analysis of PFCs via LC-MS/MS has generally been conducted using electrospray ionization operating in negative ionization mode [96, 111]. For ionic PFCs, including PFSA, PFCA, FTCA/FTUCA and FTs, the pseudo molecular ion ($[M-H]^-$) is observed. Following collision-induced dissociation, daughter ions are formed from fragmentation of the molecular ion, resulting in a precursor > product transition. Precursor > product transitions commonly monitored during the analysis of ionic PFCs are summarized in Table 3.3. The LC-MS/MS instrument is usually operated in multiple reaction

Table 3.3 Precursor > product transitions used in the LC-MS/MS analysis of PFCs. Transitions commonly used for quantitation are indicated in bold

Class	Analyte	Precursor > product transitions monitored	Nature of product ion	
PFASs	PFBS	299 > 219	(M-SO ₃) ⁻	
		299 > 99	FSO ₃ ⁻	
	PFHxS	299 > 80	SO ₃ ⁻	
		399 > 319	(M-SO ₃) ⁻	
	PFOS	399 > 99	FSO ₃ ⁻	
		399 > 80	SO ₃ ⁻	
	PFDS	499 > 419	(M-SO ₃) ⁻	
		499 > 99	FSO ₃ ⁻	
	PFCAs	PFHxA	499 > 80	SO ₃ ⁻
			599 > 519	(M-SO ₃) ⁻
PFHpA		599 > 99	FSO ₃ ⁻	
		599 > 80	SO ₃ ⁻	
PFOA		313 > 269	(M-COOH) ⁻	
		313 > 119	C ₂ F ₅ ⁻	
PFNA		363 > 319	(M-COOH) ⁻	
		363 > 169	C ₃ F ₇ ⁻	
PFDA		413 > 369	(M-COOH) ⁻	
		413 > 119	C ₂ F ₅ ⁻	
PFUA	463 > 419	(M-COOH) ⁻		
	463 > 169	C ₃ F ₇ ⁻		
PFDoA	513 > 469	(M-COOH) ⁻		
	513 > 119	C ₂ F ₅ ⁻		
PFTriA	563 > 519	(M-COOH) ⁻		
	563 > 169	C ₃ F ₇ ⁻		
PFTetA	613 > 569	(M-COOH) ⁻		
	613 > 119	C ₂ F ₅ ⁻		
PFPA	663 > 619	(M-COOH) ⁻		
	663 > 169	C ₃ F ₇ ⁻		
PFHxDA	713 > 669	(M-COOH) ⁻		
	713 > 119	C ₂ F ₅ ⁻		
FTCAs/FTUCAs	6:2 FTCA	763 > 719	(M-COOH) ⁻	
		763 > 169	C ₃ F ₇ ⁻	
	6:2 FTUCA	813 > 769	(M-COOH) ⁻	
		813 > 119	C ₂ F ₅ ⁻	
	8:2 FTCA	377 > 293	(M-CO ₂ + 2HF)	
		377 > 63	C ₂ HF ₂	
	8:2 FTUCA	357 > 293	(M-CO ₂ + HF)	
		477 > 393	(M-CO ₂ + 2HF)	
	10:2 FTCA	477 > 63	C ₂ HF ₂	
		457 > 393	(M-CO ₂ + HF)	
10:2 FTUCA	577 > 493	(M-CO ₂ + 2HF)		
	577 > 63	C ₂ HF ₂		
	557 > 493	(M-CO ₂ + HF)		
	327 > 307	(M-HF) ⁻		

(continued)

Table 3.3 (Continued)

Class	Analyte	Precursor > product transitions monitored	Nature of product ion	
FTSs	4 : 2 FTS	327 > 287	(M-2HF) ⁻	
		327 > 81	HSO ₃ ⁻	
		327 > 80	SO ₃ ⁻	
		427 > 407	(M-HF) ⁻	
	6 : 2 FTS	THPFOS	427 > 387	(M-2HF) ⁻
			427 > 81	HSO ₃ ⁻
			427 > 80	SO ₃ ⁻
	8 : 2 FTS		527 > 507	(M-HF) ⁻
			527 > 487	(M-2HF) ⁻
			527 > 81	HSO ₃ ⁻
		527 > 80	SO ₃ ⁻	

monitoring mode (MRM) so that multiple transitions can be monitored simultaneously. This permits the analysis of a suite of PFCs with one injection and also allows monitoring of multiple precursor > product transitions for each individual PFC. Quantitation is generally based on the most abundant precursor > product transition [96, 106]. It should be noted that $m/z = 80$ is the most abundant product ion observed in the fragmentation of PFOS (and other PFSAs), but interference with this ion has been observed in samples [105] and, as such, 499 > 99 is the precursor > product transition most often used for the quantitative analysis of PFOS in biological samples. Using an LC-MS/MS method for the separation of PFOS isomers, Benskin, Bataineh and Martin [117] have identified the interference at 499 > 80 as taurodeoxycholate and have illustrated that it can be effectively separated from the analyte of interest. Typical detection limits obtained using LC-MS/MS for the analysis of ionic PFCs range from pg/L to ng/L for water samples, ng/g wet weight for biota and from pg/g to ng/g for soils and sediments [96].

In addition to ionic PFCs, LC-MS/MS has also been employed for the analysis of neutral PFCs. PFOSA is commonly analysed as it can be deprotonated in solution. The precursor > product transition that is typically monitored and used for quantitation is 498 > 78 (SNO₂⁻) [105]. NMeFOSE, NEtFOSE and the FTOHs have also been analysed via LC-MS/MS. These PFCs produce very little molecular ion and are typically monitored as alcohol-acetate adducts [111, 118].

One limitation of LC-MS/MS methodology is that compounds in the sample extract, typically lipids, can affect the initial ionization of the analyte. This is referred to as matrix effects and can either enhance or suppress the electrospray ionization, leading to considerable inaccuracies in both qualitative and quantitative analyses [96, 97]. As such, the clean-up methodology employed, especially when working with biological samples, is of the utmost importance. In addition, the use of mass-labelled internal standards and matrix-matched standards, can minimize matrix effects [93, 94].

3.5.5 Analysis via Gas Chromatography–Mass Spectrometry

For the analysis of neutral, volatile PFCs, including FSAs and FTOHs, gas chromatography–mass spectrometry (GC-MS) is typically the method of choice. Martin *et al.* [99]

initially developed a GC-MS method for the analysis of FSAs and FTOHs in air samples. This method has been used and modified by other researchers [74, 100–102].

Typically, FSAs and FTOHs are separated on a DB-WAX, DB-35 or equivalent column [74, 99–102]. These PFCs can be ionized using either electron or chemical ionization [57, 99]. Chemical ionization offers higher sensitivity and specificity resulting from an abundant pseudo molecular ion ($[M + H]^+$ or $[M - H]^-$), and is the ionization of choice [94, 102]. Positive chemical ionization (PCI) produces a simple, yet definite mass spectra in comparison to the elaborate spectra obtained using negative chemical ionization (NCI) [58, 102], and is usually used for identification and quantification. During analysis, the mass spectrometer is operated in single ion monitoring mode (SIM) and several ions are monitored simultaneously for each PFC. Ions typically observed during the GC-MS analysis of FSAs and FTOHs are outlined in Table 3.4. As only one ion is observed in the PCI spectrum of PFOSA, NMeFOSA and NEtFOSA, the presence of these analytes is typically confirmed using NCI (Table 3.4). Identification is based on the observation of multiple ions, specific ratios of observed ions and conservation of retention time compared to a chemical standard, while quantification is usually based on the pseudo molecular ion.

FTCAs and FTUCAs are also amenable to GC-MS analysis. The mass spectrometry of these PFCs using both positive and negative chemical ionization has been investigated by Ellis and Mabury [58].

GC-MS cannot be used directly for the analysis of PFCAs, but has been used for the measurement of PFCAs following derivatization. For example, GC-MS has been used for the analysis of PFCAs in groundwater after derivatization with methyl iodide [90] and for the analysis of PFCAs derivatized to the 2,4-difluoroanilide in polar bear liver [119], human blood [120], precipitation [121, 122], surface water [121] and sewage treatment plant discharge [121]. A GC-MS method has also been developed by De Silva and Mabury [119, 120] for the separation of PFCA isomers, following derivitization, in environmental samples. A comparison of GC-MS and LC-MS/MS methods for the analysis of sewage treatment plant discharge samples indicated nearly identical results for the two analysis techniques [121]. PFOS and other PFSA derivatives are unstable and therefore not amenable to analysis via GC-MS [96, 111].

Table 3.4 Ion fragments observed in the GC-MS analysis of PFCs. Pseudo molecular ions are typically used for quantitation (indicated in bold)

Class	Analyte	Ions (m/z) in PCI	Ions (m/z) in NCI
FSAs	NMeFBSE	340, 358	
	NEtFBSE	354, 372	
	PFOSA	500	483, 400
	NMeFOSA	514	483, 512 , 400
	NEtFOSA	528	483, 400, 526
	NMeFOSE	540, 558	
	NEtFOSE	554, 572	
	FTOHs	4:2 FTOH	265 , 227, 293
6:2 FTOH		365 , 327, 393	
8:2 FTOH		465 , 427, 493	
10:2 FTOH		565 , 527, 593	
12:2 FTOH		665 , 627, 693	

3.5.6 Analysis via Nuclear Magnetic Resonance

Nuclear magnetic resonance (NMR) was first used for the analysis of PFCs in human serum by Taves in the 1960s [123]. Since that time, use of NMR for measurement of PFCs in environmental samples has been limited. Moody *et al.* [124] employed ^{19}F NMR for the measurement of ionic PFCs in surface water samples collected immediately following an accidental spill of aqueous fire fighting foam, when high concentrations of PFCs were present. Quantitation was based on the peak area of the terminal CF_3 group and the limit of detection was $10\ \mu\text{g/L}$. Results obtained using the ^{19}F NMR method were consistently higher compared to those obtained via LC-MS/MS. The researchers attributed these discrepancies to the possible presence of other fluorinated surfactants in the samples. Results of this study indicate that information obtained using the ^{19}F NMR method complements the LC-MS/MS methodology by providing unequivocal structural information [124].

3.5.7 Total Fluorine Analysis

One of the oldest methods in the literature for the measurement of organic fluorine compounds is the Wickbold method [125], where organic fluorine is converted to hydrogen fluoride via combustion. The Wickbold method is useful for determining the total organic fluorine content of a sample, but is nonspecific and does not provide information on individual fluorinated molecules. In addition, for samples containing PFCs, the combustion may lead to incomplete decomposition and subsequent underestimation of the total fluorine content of the sample [125].

A method for the determination of trace levels of total fluorine in environmental samples has been developed by Miyake *et al.* [126, 127]. In this mass balance approach, total fluorine in a sample is measured using combustion ion chromatography. The sample is then fractionated into organic and inorganic fractions using solvents, and each fraction is analysed for total fluorine, extractable organic fluorine and fluoride (inorganic fluorine). The organic phase is also analysed via LC-MS/MS for known PFCs to enable calculation of the fraction of total fluorine that is contributed by PFCs. This method has been employed for both seawater [126] and human blood samples [127]. Results indicate the presence of uncharacterized organofluorine compounds in both sample sets and the need for further research in this area.

3.5.8 Analytical Challenges

In addition to background contamination, other challenges are associated with the measurement of PFCs in environmental samples. In particular, challenges are associated with standards, calibration and quantitation, and matrix effects [93, 94].

Until recently, obtaining high-quality chemical standards for the analysis of PFCs was difficult. Although some standards were available commercially, others were available only from manufacturers, and had variable purity and isomer profiles [94, 128]. These impurities and structural isomers were not always well documented and could contribute to inaccurate analytical results. For example, shorter chain PFCA impurities observed in a chemical standard of PFTA could result in a negative bias of unknown proportions in quantitation when mixed standard solutions are used without correction [94]. Today, an increasing

number of well-characterized PFC standards are commercially available. In addition, as discussed above, both LC-MS/MS and GC-MS methods to separate isomers of PFCs have been developed [116, 117, 119] and can be incorporated into analytical techniques for more accurate measurements.

Obtaining appropriate internal standards and standard reference materials has also proven difficult [94]. As a result, researchers have employed a variety of chemicals for internal standards [93]. For example, Hansen *et al.* [105] used the 6:2 FTS/THPFOS to quantify PFHxS, PFOS, PFOA and PFOSA in biological matrices. This internal standard was subsequently measured in groundwater samples from military bases [98] and illustrates the importance for researchers to scan samples for any analyte being used as an internal standard. A suite of ^{13}C - and ^{18}O -mass labelled PFCs have become commercially available and it is recommended they be employed as internal standards [93, 97, 128]. Prior to use, it is suggested that the purity of these labelled standards be confirmed to ensure the absence of native (unlabelled) PFCs.

To investigate the data quality of PFC measurements, a worldwide interlaboratory study was conducted in 2005 involving 38 laboratories from 13 countries [93]. Each laboratory analysed 13 PFCs in three environmental samples and two human samples. Results indicated approximately 65% agreement for PFOS and PFOA in human blood and plasma samples, but agreement for other PFSA and PFCA was much lower and most laboratories underestimated the PFC concentrations in fish extracts due to matrix effects. The study concluded that additional work is needed to improve the analytical techniques employed for the analysis of PFCs.

Several recommendations arose from the interlaboratory study to minimize analytical challenges and to ensure data quality. As discussed above, it is recommended that mass labelled PFCs be employed as internal standards [93, 97]. It should be noted, however, that some electrospray ionization suppression may still occur if these internal standards are used at high concentrations [97]. Matrix effects can also be minimized by employing matrix-matched calibration standards in lieu of solvent-based calibration standards [97]. Unfortunately, matrix-matched standards can be impractical when an appropriate 'clean' matrix cannot be found [94]. Other quality assurance and quality control measures, such as spike and recovery analyses of an analyte added to the sample matrix, repetitive analysis of samples to determine precision and comparison of internal standard quantitation to quantitation via standard additions, are also useful in determining data quality [94].

3.6 Human Exposure

The presence of organic fluorine in humans was first reported by Taves in 1968, although analytical methodologies were not adequate at the time for identification of specific PFCs [123]. In the past several years, primarily due to advances in analytical chemistry techniques, PFSA and PFCA have been measured globally in human whole blood, plasma and serum [105, 108, 129–133]. Concentrations of PFSA and PFCA in human populations in North America and worldwide have been reviewed by Lau *et al.* [23].

In the general population, PFOS is the predominant PFC observed in human blood, with mean concentrations generally $<40\text{ ng/g}$ [108, 129, 133]. In individuals employed in the fluorochemical industry, PFOA is the predominant PFC observed. In occupationally

exposed individuals, observed levels of both PFOA and PFOS are approximately one order of magnitude higher than those reported in the general population [23], with mean concentrations of 5 µg/g and 1 to 2 µg/g respectively [134]. Studies of occupationally-exposed workers have suggested that the mean biological half-life of PFOS, PFHxS and PFOA in human serum is 5.4, 8.5 and 3.8 years respectively [135].

Generally, higher concentrations of PFOS are observed in males than females [132]. PFASs and PFCAs have also been shown to vary among ethnic groups in the United States, concentrations decreased as follows: non-Hispanic whites > non-Hispanic blacks > Mexican Americans [133]. Humans typically have much greater concentrations of PFOA than wildlife and overall PFC contamination profiles between humans and wildlife are different, suggesting different sources [136]. In addition to blood, PFASs and PFCAs have been observed in maternal and cord blood of a pregnant woman [137], human breast milk [138] and seminal fluid [131], indicating the exposure of these contaminants to human fetuses and their presence in the human reproductive system.

PFASs and PFCAs are not the only PFCs observed in humans. PFOSA has also been observed in human tissue [23]. A recent study investigating total fluorine concentrations in human blood by Miyake *et al.* [127] suggests the presence of other, yet uncharacterized, organic fluorine compounds in humans.

Routes of human exposure to PFCs have not been well characterized and are complicated as it is likely that several sources are involved, with relative contributions varying depending on lifestyle and geographic location [108, 133]. The general population may be exposed to PFCs via direct contact with treated consumer products or the intake of contaminated food items, air, water or dust [23, 139].

Washburn *et al.* [140] examined exposure to PFOA in a variety of consumer products including clothing, upholstery, sealants, waxes, paints and cleaners, and concluded that direct exposure to PFOA from the appropriate use of products treated with fluorinated polymers is not a significant source of contamination to the general public. Studies investigating the direct exposure to PFOS and other PFASs in consumer articles have not yet been published in the peer-reviewed literature.

It has been established that not all FSAs and/or FTOHs become chemically linked during the manufacture of fluorinated polymers and free FSAs, and/or FTOHs are present in many commercial products [6, 141, 142]. These residual FSAs and FTOHs may be a source of human exposure, although their significance has not yet been investigated. In products formerly produced by the 3M Company, the concentration of residual material (free FSAs not linked to the polymeric backbone) was typically 1 to 2% or less [6]. In a recent study, residual FSAs and FTOHs in a variety of commercially available and industrially applied products ranged from 0.04 to 3.8% on a fluorinated alcohol to dry mass basis [141]. Degradation of FSAs and FTOHs may also represent an indirect source of PFASs and/or PFCAs to humans.

Food items can become contaminated with PFCs in a variety of methods. For example, food derived from animals may be contaminated due to exposure of the animal to PFCs [139]. PFCs are used in grease- and water-repellent coatings for food packaging, and food can also become contaminated directly from packaging materials [143]. Begley *et al.* [143] showed that PFCs applied on food packaging can migrate into food. Accordingly, PFCs have been observed in composite samples from food items such as baked goods,

dairy, eggs, fish, shellfish, fast food and microwave popcorn [139, 144]. Concentrations of FSAs ranged from below the detection limit to 27 ng/g wet weight [144], while concentrations of PFOS and PFCAs ranged from 0.5 to 4.5 ng/g [139].

Dietary exposure to PFCs was also indirectly examined by Falandysz *et al.* [145]. PFSA and PFCAs were analysed in blood samples collected from adults in Poland. A correlation was observed between PFSA and PFCa concentrations in blood and self-reported Baltic fish consumption.

A risk assessment to investigate the likelihood that dietary exposures of PFOS and PFCAs could cause adverse human health effects was conducted by Tittlemier *et al.* [139]. Toxicological reference points were compared with estimated daily exposure to PFOS and PFCAs from food to derive margin of exposure (MOE) estimates. MOE values for PFOS and PFOA were greater than 1.6×10^4 and 2.7×10^5 respectively, indicating that a difference exists between the average Canadian's dietary exposure and the doses eliciting effects in toxicological feeding studies involving nonhuman primates and rodents [139].

The indirect exposure to PFCAs through ingestion of chemicals applied to food contact paper packaging was investigated by D'eon and Mabury [146]. In this study, the load of PFCAs in rats was quantified following exposure to polyfluoroalkyl phosphate surfactants (PAPS), a class of nonpolymeric PFCs approved for application to food contact paper products. Increased levels of PFOA were observed in the dosed animals, linking ingestion of PAPS with *in vivo* production of perfluorinated acids [146].

A comparison study examining possible sources of PFOS and PFCAs to humans was conducted by Tittlemier *et al.* [139]. The estimated daily intake of PFCAs and PFOS for Canadians ≥ 12 years of age was 410 ng/day. Of that, 250 ng/day were estimated from food sources and accounted for 61% of the total daily PFC exposure. PFC-treated consumer goods, such as carpets and apparel, accounted for an estimated 120 ng/day. Daily intakes of PFCs via water, dust and air were estimated to be 0.3, 28 and 12 ng/day respectively.

De Silva and Mabury [120] investigated the isomer distribution of PFCAs in human blood and observed linear isomers of PFCAs to be predominant. This observation is suggestive that organisms are more exposed to a linear source of PFCAs, such as linear FTOHs produced by the telomerization process [120]. It is important to note that isomeric distribution of PFCAs cannot yet provide conclusive evidence with regards to source, as PFCa isomer discrimination in biological samples is not yet fully understood. For example, it is possible that linear isomers are preferentially absorbed and/or branched isomers are more readily eliminated [120, 147]. Additional biomonitoring studies are required to characterize trends of human exposure better.

3.7 Sources of PFCs to the Environment

3.7.1 Sources of FSAs and FTOHs

Sources of FSAs and FTOHs to the environment are not completely characterized, but are hypothesized to be of both a direct and indirect nature. Direct sources include disposal, spills and releases during manufacturing and application processes. As discussed above, not all FSAs and/or FTOHs become chemically linked during the manufacture of fluorinated

polymers, and as such free FSAs and/or FTOHs are present in many commercial products [6, 141, 142] and can enter the environment directly. It is worth noting that DuPont has announced its intention to implement manufacturing technology that will reduce residual (unbound) FTOHs in their products [8].

Indirect sources of FSAs and FTOHs are more difficult to assess. It has been hypothesized that fluorinated polymers may degrade under environmental abiotic and/or biotic conditions to produce FTOHs and FSAs [141, 148]. To date, degradation of fluorinated polymers has not yet been confirmed, although degradation of FTOH-containing monomers to FTOHs has been observed [149]. If this hypothesis regarding the degradation of polymers is true, it is possible that FTOHs and FSAs could also be released to the environment indirectly via degradation following spills of fluorinated polymers or products containing fluorinated polymers, due to leaching from consumer products over time and during disposal of products containing or treated with fluorinated polymers.

3.7.2 Sources of PFSA and PFCA

Like FSAs and FTOHs, sources of PFSA and PFCA to the environment are also not completely characterized. Direct sources of PFSA and PFCA include use, disposal, spills and releases during the manufacturing process of PFSA and PFCA themselves, in addition to the manufacturing of products containing PFSA and PFCA [14]. As previously discussed, the aggressive nature of the ECF manufacturing process can result in the production of chemical by-products, including shorter and longer PFSA and PFCA homologues [4], which could enter the environment directly. Similarly, PFOA has been identified, in trace levels, as a chemical by-product of the manufacturing process of FTOH-based fluorinated polymers [150]. In addition, due to their role as processing aids, significant quantities of PFOA and other PFCA, particularly PFNA, may also be released to the environment during the production of fluoropolymers [7, 14].

The first report of an indirect source of PFCA to the environment was the thermolysis of fluoropolymers [151, 152]. FTOHs and FSAs have also been identified as indirect sources. Degradation of FTOHs results in the production of PFCA, under both abiotic [153–155] and biological [40, 103, 104, 156, 157] conditions. PFSA are also observed in the biological degradation of FSAs [158, 159], while abiotic degradation of FSAs produces both PFCA and PFSA [160, 161].

3.7.3 Sources of PFSA and PFCA to the Arctic

The origin and transport pathways of PFSA and PFCA in the Arctic is a topic of interest that has received considerable attention by researchers. In particular, two hypotheses have been proposed to explain the sources of PFSA and PFCA to the Arctic. It is important to note that proponents of both hypotheses agree that both transport routes are likely to occur simultaneously. However, the relative importance of each transport route is unknown.

The first hypothesis suggests an indirect route, where FSAs and FTOHs undergo long-range atmospheric transport to the Arctic and subsequent abiotic and/or biotic degradation results in the production of PFSA and PFCA [26, 99, 100]. Atmospheric lifetimes of the FTOHs, as determined by reaction with OH radicals, regardless of the length of the perfluoroalkyl chain, have been determined to be approximately 20 days and, as such, are

sufficient for widespread dissemination in the northern hemisphere and long-range transport [162]. Smog chamber studies have indicated that, in the absence of NO_x , FTOHs can undergo atmospheric oxidation to form a homologous series of PFCAs [153, 154]. FTOHs have also been shown to produce PFCAs following indirect photolysis in natural waters [155]. Biological degradation of FTOHs has been observed to produce PFCAs in both microbial [103, 104] and mammalian [40, 156, 157] studies.

Similar to the FTOHs, smog chamber studies of the FSAs also indicate that atmospheric transport to remote regions is possible [160, 161]. The atmospheric lifetime for NMeFBSE, as determined by reaction with OH radicals, is approximately 2 days [161], and it is assumed that the atmospheric lifetime of NEtFBSE would be similar. As such, it is unlikely that these compounds would undergo global long-range atmospheric transport, but continental transport is possible. The gas phase *N*-dealkylation products of NMeFBSE and NEtFBSE, *N*-methyl perfluorobutane sulfonamide (NMeFBSA) and *N*-ethyl perfluorobutane sulfonamide (NEtFBSA) respectively have atmospheric lifetimes ≥ 20 days [160, 161], thus allowing substantial long-range transport. In the absence of NO_x , the atmospheric oxidations of NEtFBSA and NMeFBSE have been shown to result in the production of both PFSA and PFCAs [160, 161]. Using these observations as a guide, it is likely that NMeFOSE and NEtFOSE will undergo similar atmospheric transport and oxidation. In addition, biological degradations of NEtFOSE and NEtFOSA have been observed to produce PFSA in both fish [159] and mammalian [158, 159] studies.

The alternative hypothesis suggests a direct route, where long-range oceanic transport can account for the presence of PFCAs in the Arctic Ocean and thus in Arctic biota [14, 163, 164]. As will be discussed later in more detail, PFOS, PFOA, PFNA and PFHxS have been reported in open ocean waters of the Pacific and Atlantic and in coastal waters of Japan, Korea and China [95, 112, 165]. Modelling studies indicate that the observed PFOA concentrations in oceans can be accounted for by historical and projected PFOA emissions [14, 163, 164].

Stock *et al.* [166] identified that, in addition to the direct and indirect sources discussed above, a third route by which PFCs reach the Arctic is local contamination. PFOA, PFHpA, PFHxS and PFOS were observed in Resolute Lake in the Canadian Arctic at concentrations (up to 90 ng/L) that were nearly 60 times that observed in other, nearby Arctic lakes. The contamination of Resolute Lake was proposed to be as a result of a nearby airport wastewater input and did not appear to be widespread.

3.8 Environmental Measurements

It is widely recognized that PFCs, due to their persistence, are ubiquitous in all phases of the natural environment including the atmosphere, precipitation, groundwater, surface waters, sediments and wildlife.

3.8.1 Atmosphere

FSAs and FTOHs were first observed in the atmosphere in 2002, by Martin *et al.* [99]. Concentrations of combined FTOHs and FSAs ranged from 20 to 85 pg/m^3 and 7 to

393 pg/m³ at an urban (Toronto, Ontario) and a rural (Long Point, Ontario) sampling location respectively. Concentrations of Σ FSA and Σ FTOHs were measured in six North American cities with average concentrations ranging from 22 to 403 pg/m³ and 11 to 165 pg/m³ respectively [100]. In this study, larger concentrations of individual FSAs were observed near possible point source locations. FSAs have also been observed in urban Canadian cities by Shoeib *et al.* [74, 167], in both indoor and outdoor locations. Mean indoor concentrations of NMeFOSE and NEtFOSE (1490 pg/m³ and 740 pg/m³ respectively) were approximately 10 to 20 times greater than mean outdoor concentrations (82 pg/m³ and 87 pg/m³ respectively), indicating that indoor air may in fact be a source of FSAs to the outside environment [167]. Boulanger *et al.* [118] collected air samples above Lake Ontario and observed NEtFOA and NEtFOSE at concentrations ranging from 0.5 to 1.1 pg/m³.

FSAs and FTOHs have also been observed in the European atmosphere [102, 168, 169]. Berger *et al.* [168] collected samples from two English cities and observed FSAs and FTOHs at concentrations ranging from < 1 to 29 pg/m³ and 9 to 326 pg/m³ respectively. FSAs and FTOHs were also observed in the German atmosphere [102, 169] with average concentrations of Σ FSA and Σ FTOH ranging from 12 to 151 pg/m³ and 64 to 546 pg/m³ respectively. Similar to that observed in the North American atmosphere, in the European studies, elevated concentrations were also observed in samples collected from urban versus rural or remote locations. Volatile PFCs have also been detected in the arctic atmosphere. Shoeib, Harner and Vlahos [101] observed 6:2, 8:2 and 10:2 FTOHs, NMeFOSE and NEtFOSE at concentrations ranging from below detection limits to 31 pg/m³, during a crossing of the North Atlantic and Canadian Arctic Archipelago. FTOHs and FSAs have also been reported in the Canadian Arctic atmosphere [166]. Typically, observed concentrations of FSAs and FTOHs were on the same order of magnitude as concentrations reported in lower-latitude source regions [101, 166].

PFSA and PFCA have also been detected in the atmospheric environment. PFOS was first observed in atmospheric particulate matter in two Japanese cities in 2003 by Sasaki *et al.* [170] at concentrations ranging from nondetectable values to 21.8 pg/m³. PFOS was also observed in atmospheric particles above Lake Ontario by Boulanger *et al.* [118] at concentrations up to 8.1 pg/m³. Berger *et al.* [168] observed PFSA and PFCA in the particulate phase of air samples collected in England, at concentrations ranging from nondetectable values (PFUA and PFDoA) to 828 pg/m³ (PFOA). PFOA was observed at elevated concentrations of 0.1 to 3.84 μ g/m³ in ambient air outside a manufacturing facility [171]. A recent investigation of arctic glacial ice caps that receive contamination solely from the atmosphere also reported the observation of PFNA, PFOA, PFDA, PFUA and PFOS [113]. Concentrations of PFSA and PFCA, ranging from <0.1 to 5.9 pg/m³ were also observed on atmospheric particles from the Canadian Arctic [166].

3.8.2 Precipitation

Several studies have examined the presence of PFCs in precipitation. Loewen *et al.* [172] examined a rainfall event sample collected from Winnipeg, Manitoba, and observed PFOS at a concentration of 0.59 ng/L, but PFCA were not observed above method detection limits (1.1 to 7.2 ng/L). FTCA and FTUCA were also observed; concentrations of 8:2 and 10:2

FTCAs were 1.0 ng/L and 0.3 ng/L respectively, while the 8:2 and 10:2 FTUCAs were both observed at 0.12 ng/L. Scott *et al.* [121, 122] examined PFCAs ($n = 2$ to 10) and 8:2 and 10:2 FTCAs and FTUCAs in precipitation samples collected from nine sampling locations throughout North America. Excluding TFA and perfluoropropanoate (PFPrA, $n = 3$), PFOA was the predominant PFCA observed in most sampling locations. In samples collected from remote sites, concentrations of PFOA ranged from <0.1 to 6.1 ng/L, while at urban or near-urban sites, concentrations of PFOA were generally much larger and ranged from 0.6 to 89 ng/L. Longer chain PFCAs ($n = 10, 11$ and 12) were observed at concentrations ranging from <0.07 to 5.2 ng/L. The 8:2 and 10:2 FTCAs and FTUCAs were observed in all samples collected from urban and near-urban sites; concentrations ranged from <0.07 to 8.6 ng/L.

3.8.3 Groundwater

Use of aqueous fire fighting foams at military bases has led to the contamination of groundwater with PFSAs, PFCAs and FTSs [98, 173]. PFCAs were first identified in groundwater at Naval Air Station Fallon, Nevada, and Tyndall Air Force Base, Florida, in 1999 by Moody and Field [90]. Total concentrations of PFCAs ($n = 6$ to 8) observed ranged from 125 to 7090 $\mu\text{g/L}$. PFHxS, PFOS, PFHpA and PFOA (concentrations ranging from 3 to 120 $\mu\text{g/L}$) were also observed in groundwater at Wurtsmith Air Force Base, Michigan [174]. Total concentrations of FTSs ($n = 4, 6, 8$) observed in groundwater collected from both Tyndall and Wurtsmith Air Force Bases ranged from below quantitation (<0.06) to 14 600 $\mu\text{g/L}$.

3.8.4 Surface Waters

PFSAs and PFCAs were first observed in surface waters following the accidental release of 22 000 L of aqueous fire fighting foam in June 2000 into Etobicoke Creek, a tributary of Lake Ontario [85, 124]. PFOS was the predominant PFC observed. Combined concentrations of PFOS, PFHS and PFOA ranged from 0.011 to 2270 $\mu\text{g/L}$. PFHpA and PFBS were also observed quantitatively. It is interesting to note that PFOS, PFHxS and PFOA were also observed, in lower concentrations, in surface water samples collected upstream of the spill location. Subsequent studies have observed PFCs in a variety of surface waters including rivers [88, 110, 175–178], lakes [114, 121, 166, 179–181] and seas and oceans [86, 95, 112, 165, 175–177, 182].

PFSAs and PFCAs have been observed in samples collected from rivers in North America, Europe and Asia. Hanson *et al.* [110] observed PFOS and PFOA in the Tennessee River near a fluorochemical manufacturing plant in Decatur, Alabama (concentrations ranging from 16.8 to 144 ng/L and <25 to 598 ng/L respectively). PFOS and PFOA were detected throughout the river, although increased concentrations were observed downstream of the fluorochemical manufacturing facility. Saito *et al.* [175, 176] measured PFOS and PFOA in 126 Japanese rivers, at concentrations similar to that observed by Hanson *et al.* [110]. Concentrations of PFOS ranged from 0.3 to 157 ng/L, with maximum contamination observed in the Jinzu (135 ng/L) and Tama Rivers (157 ng/L), while observed concentrations of PFOA were much larger, ranging from 0.28 to 456 ng/L. Highest PFOA concentrations were observed in rivers of the Kinki District, where a public water disposal

site, releasing 18 kg of PFOA daily, was identified as the probable source of contamination [176]. In the Raisin and St Clair Rivers, two rivers in the Great Lakes system, the presence of PFOS and PFOA was investigated by Kannan *et al.* [88]. Concentrations of PFOS and PFOA were similar, 1.9 to 3.9 ng/L and 4.0 to 14.7 ng/L respectively. Tseng *et al.* [177] monitored PFOA, PFOS and PFDA in two rivers in Taiwan. Concentrations ranged from 4.0 to 181 ng/L and were similar to those observed in Japanese surface waters. Skutlarek, Exner and Farber [178] observed a suite of PFSAAs ($n = 4$ and 8) and PFCAs ($n = 4$ to 8) in the Rhine, Ruhr and Moehne River systems in Germany. Concentrations of Σ PFSAAs and PFCAs in the Rhine River system (ranging from nondetectable values to 178 ng/L) were much less than those observed in the Ruhr and Moehne River systems (total concentrations up to 4385 and 43348 ng/L respectively). The legal application of organic and inorganic wastes to agricultural lands within the river systems were proposed as possible sources of the observed contamination.

Several studies have investigated the presence of PFCs in the Great Lakes and smaller lakes of the Great Lakes region. PFCs were first observed in the Great Lakes by Boulanger *et al.* [179]. In this study, 16 samples from Lake Ontario and Lake Erie were analysed. PFOS and PFOA were the predominant PFCs observed, with concentrations ranging from 21 to 70 ng/L and 27 to 50 ng/L respectively. PFOSA was also observed (0.6 to 1.3 ng/L), while neither NETFOSA nor NETFOSE were detected. It should be noted, however, that concern has arisen surrounding the validity of these measurements [183] and reported values are an order or magnitude greater than more recent measurements. Simcik and Dorweiler [180] investigated the presence of PFOS and several PFCAs ($n = 7$ to 10) in Lake Michigan, Lake Superior and other surface waters in the surrounding area. Concentrations of PFCs were observed to be higher in urban versus remote sampling locations. PFOS was the dominant PFC observed; concentrations ranged from nondetectable values to 1.2 ng/L in remote locations and 24 to 46 ng/L in urban locations. Concentrations of PFOA ranged from 0.14 to 0.66 ng/L and 0.45 to 19 ng/L in remote and urban sites respectively. PFHpA was observed in all samples collected (concentrations generally < 10 ng/L) while PFNA and PFDA were only detected in several samples.

Scott *et al.* [121] measured a suite of PFCAs ($n = 2$ to 8) in water samples collected from depth profiles in Lake Ontario. PFCAs were observed at all depths, with largest concentrations for the shorter chained PFCAs ($n = 2$ to 4). Mean concentrations of PFOA were 2.5 ng/L, while other PFCAs ($n = 5$ to 7) were observed at concentrations of about 1 ng/L. PFOA and PFNA were also observed in Lake Huron and Lake Superior by Scott *et al.* [121], with concentrations ranging from 0.03 to 1.8 ng/L. Sinclair *et al.* [181] investigated the presence of PFOA, PFOS, PFHxS and PFOSA in Lake Erie and Lake Ontario and other surface waters in New York State. PFOA was the predominate PFC observed, with concentrations ranging from 10 to 173 ng/L in all samples. PFOS and PFHxS concentrations were generally lower, ranging from 0.8 to 30 ng/L and 0.5 to 8.5 ng/L respectively. A notable exception was Lake Onandaga, where elevated PFOS concentrations were observed (198 to 1090 ng/L). PFOSA was not observed in any surface waters above the method detection limits (2.5 ng/L). Furdui *et al.* [114] measured PFOSA, PFSAAs ($n = 6$ and 8) and PFCAs ($n = 7$ to 12) in all the Great Lakes with the exception of Lake Michigan. PFCs were observed in all lakes, generally at concentrations less than 7 ng/L. However,

elevated concentrations of PFOS (37.6 ng/L) were observed in samples collected from Hamilton Harbour in Lake Ontario.

The presence of PFSAAs ($n=6, 8$ and 10) and PFCAs ($n=7$ to 12) in four lakes on Cornwallis Island in the Canadian Arctic were investigated [166]. In Amituk and Char Lakes, concentrations of PFSAAs and PFCAs ranged from nondetectable values to generally less than 5 ng/L and were similar to concentrations observed in lakes in lower latitudes. Conversely, in Resolute and Meretta Lakes, concentrations of PFHxS, PFOS, PFHpA and PFOA ranged from 5.6 to 69 ng/L, and were generally larger than concentrations observed in the Great Lakes. As discussed previously, local contamination such as the use of aqueous fire fighting foam or discharge of wastewater from a former airport base was hypothesized as a point source.

PFCs were first observed in seawater by Saito *et al.* [175, 176], who measured PFOS and PFOA in coastal water samples collected in Japan. Concentrations of PFOA (1.90 to 447 ng/L) were significantly larger than those observed for PFOS (0.2 to 27.69 ng/L). Subsequent studies of PFSAAs and PFCAs in seawater have reported similar concentrations. PFOSA, PFSAAs and PFCAs have been investigated in the coastal waters of Japan, China and Korea by several research groups [86, 95, 112, 165, 182]. Generally, low ng/L concentrations were reported, with maximum concentrations of PFOS (730 ng/L) and PFOA (320 ng/L) reported in the coastal waters of Korea [165]. High concentrations of PFCs were also reported in Tomakomia Bay, Japan [182], following the accidental release of aqueous fire fighting foam; elevated concentrations of PFOS (2550 to 2880 ng/L), PFHxS (92 to 96 ng/L) and PFOSA (351 to 380 ng/L) and some PFCAs (up to 343 ng/L) were observed. Tseng *et al.* [177] observed PFBS, PFOS, PFOA and PFDA in two samples collected from the coastal waters of Taiwan. Concentrations ranged from 60 to 920 ng/L and were consistent with earlier studies. PFOSA, PFSAAs ($n=6$ and 8) and PFCAs ($n=8$ and 9) have also been reported in the open ocean waters by Yamashita *et al.* [95, 112]. Reported concentrations ranged from 0.1 pg/L (PFHxS) to 439 pg/L (PFOA). Generally lower concentrations were observed in the South Pacific Ocean and higher concentrations observed in the North Atlantic Ocean, while concentrations in the open ocean were significantly less than those observed in coastal waters.

To date, the majority of studies of PFCs in surface waters have focused on PFOSA, PFOS and PFOA, in addition to other select PFSAAs and PFCAs. It should be noted, however, that Taniyasu *et al.* [182] have developed a method for the analysis of a suite of PFCs in aquatic matrices, including not only the PFSAAs and PFCAs but also NEtFOSA and 8:2 FTCA and FTUCA. In water samples collected from Tokyo Bay and Tomakomai Bay in Japan, neither NEtFOSA nor 8:2 FTCA were observed above detection limits (0.3 and 7.0 ng/L respectively). However, 8:2 FTUCA was observed in one sample (0.14 ng/L). The 8:2 and 10:2 FTUCAs (concentrations up to 15.1 ng/L) were observed in samples collected from four lakes in the Canadian Arctic [166]. In addition, a method for the extraction and analysis of FTOHs in water has also been developed by Szostek, Prickett and Buck [184], but it has yet to be applied to real-life samples.

3.8.5 Sediments

Both PFSAAs ($n=6, 8, 10$) and PFCAs ($n=8$ to 13) have been observed in surface sediment samples from rivers and creeks in the San Francisco Bay area by Higgins *et al.* [185].

Concentrations of individual PFSA and PFCA ranged from nondetectable values to 3.76 ng/g dry weight, with PFOS, PFDS, PFOA and PFDA the most commonly detected analytes. Similar concentrations of PFOS, PFOA and PFNA (0.09 to 1.1 ng/g dry weight) were also observed in surface sediment samples collected from the tidal flats of the Ariake Sea, Japan [186].

The presence of PFSA ($n = 4, 6, 8, 10$) and PFCA ($n = 7$ to 15) were also investigated in sediment from three Lakes in the Canadian Arctic [166]. In Char and Amituk Lakes, total concentrations of PFSA and PFCA in sediment were approximately 5 and 7 ng/g dry weight respectively, while total concentration in Resolute Lake sediment was approximately 100 ng/g dry weight. In Char and Amituk Lakes, the Σ PFCA were greater than the Σ PFSA, while the opposite was true for Resolute Lake. The 8:2 and 10:2 FTUCA were also observed in sediment samples from Char and Amituk Lakes.

3.8.6 Wildlife

The first observation of PFC in wildlife was reported by Giesy and Kannan in 2001 [106]. In this study, PFOS was observed in the plasma, liver, eggs and muscle tissue of turtles, frogs, fish, birds and marine mammals, including those in remote locations such as Alaska, the Canadian and Norwegian Arctic and Antarctica. Global concentrations of PFOS ranged from < 1 to 3680 ng/g wet weight. PFOA and PFOSA were also observed in a few samples at concentrations ranging from 2.5 to 180 ng/g wet weight and 1 to 38 ng/g wet weight respectively.

Long chain PFCA ($n > 8$) were first observed in fish by Moody *et al.* [85], following an accidental release of fire fighting foam into Etobicoke Creek, a tributary of Lake Ontario. Concentrations of total PFCA ($n = 5$ to 14) in fish liver samples ranged from 0.07 to 1.02 μ g/g wet weight. The presence of long chain PFCA in biota was confirmed by Martin *et al.* [187] in 2004, who observed PFCA ($n = 8$ to 15) in a variety of marine mammals, seabirds and fish species from the Canadian Arctic, at concentrations ranging from 0.3 to 180 ng/g wet weight.

To date, it is widely recognized that PFC are ubiquitous in biota, and the topic has been reviewed by Houde *et al.* [136] and Lau *et al.* [23]. PFSA and PFCA have been measured globally in invertebrates [87, 88, 109, 188, 189], fish [85, 87, 88, 106, 109, 124, 187, 190–192], reptiles [106, 193], birds [87, 106, 190, 192, 194–197], and terrestrial [187, 198] and marine [87, 106, 107, 119, 190, 192, 199–208] mammals. The pattern of contamination in biota is complex and varies among species and locations.

Generally, PFOS is the predominant PFC observed in wildlife samples [136]. A notable exception to this are some seabird species from the Canadian Arctic, where concentrations of individual PFCA exceeded PFOS [197]. Profiles of PFC contamination vary among wildlife species and locations, indicating multiple sources of PFC, although numerous linear correlations between concentrations of different PFSA and PFCA have been observed in wildlife, indicating that exposures to various PFC may occur simultaneously and may be from a similar source within a geographic region [136]. The largest biological PFC concentrations encountered to date were observed in wood mice (*Apodemus sylvaticus*) inhabiting the area surrounding a fluorochemical plant in Belgium; concentrations of PFOS were approximately 180 000 ng/g wet weight [198].

The possibility of transfer of PFCs to offspring has been indicated in several biological monitoring studies. For example, PFSA and PFCA have been observed in the eggs of fish [88, 106] and birds [106, 194, 196], indicating that oviparous transfer to offspring may be occurring. Observed concentrations of PFCs in both calves of bottlenose dolphins (*Tursiops truncatus*) [207] and the fetus of a North Sea harbour porpoise (*Phocoena phocoena*) [201] were greater than the concentrations observed in their mothers, suggesting placental transfer and fetal accumulation of PFCs [136]. PFCs have also been observed in the milk of bottlenose dolphins, indicating that maternal transfer of contaminants occurs during lactation [207].

The majority of biological monitoring studies to date have focused on PFOSA, PFSA and PFCA. FTCA and FTUCA have been observed in some species, including seabirds and seals from the Canadian Arctic [107, 197], suggesting that FTOHs may be a source of the observed PFCA. Two studies have also investigated the presence of other FSAs in biological samples. Tomy *et al.* [87] have observed NETFOSA in an Eastern Arctic marine food web, while Taniyasu *et al.* [182] have observed NETFOSA in beaver liver samples.

Similar to species in lower-latitude regions, PFOS has typically been identified as the predominant perfluoroalkyl contaminant in arctic wildlife [136]. The largest concentrations of PFCs in arctic biota were observed in polar bears (*Ursus maritimus*) [119, 187, 204–206, 208], the apex predator in the arctic food web. In polar bears, PFOS is present at similar or higher concentrations than that of other persistent organohalogen contaminants [204, 208–210]. Accumulation profiles of PFCA in arctic biota are typically characterized by a higher concentration of odd-numbered PFCA [196, 204, 206, 209, 210], but the predominance of individual PFCA varied with species and geographic location. In arctic marine food webs, bioaccumulation and trophic transfer have also been identified as important exposure routes of PFCs [87, 192, 196]. It is also interesting to note that, typically, higher concentrations of PFCs have been observed in populations of the European arctic compared with western North American arctic populations [202, 204, 206, 208].

3.8.7 Temporal Trends

Temporal trends of PFCs in biota have been investigated in several studies and generally have shown increasing concentrations of PFCs over time. PFOS was found to significantly increase fourfold in whole lake trout homogenate from Lake Ontario between 1980 and 2001 [109]. A 30-fold increase was observed from 1968 to 2002 in mean PFOS concentrations in guillemot eggs from the Baltic Sea [211]. Similar increasing trends were also observed for thick-billed murres (*Uria lomvia*) from Prince Leopold Island between 1975 and 2004 [197]. PFOS and PFCA concentrations in the liver of polar bears from North Baffin Bay have also shown a steady increase between 1972 and 2001 [208]. Increasing concentrations of PFOS, PFDA and PFUnA were observed in ringed seals (*Phoca hispida*) from East and West Greenland from 1986 to 2003 and 1982 to 2003 respectively [202]. Temporal trend studies of ringed seals from Arviat and Resolute Bay also showed increasing concentrations of PFCA ($n = 9$ to 15) from 1992 to 2005 and 1972 to 2005 respectively [107]. However, maximum concentrations of PFOS and PFOSA were observed during 1998 and 2000, with significant decreases from 2000 to 2005, suggesting

that ringed seals and their food web are rapidly responding to the phase-out of perfluorooctyl chemistry by the 3M Company [107]. PFOS concentrations in whole eggs of herring gulls (*Larus argentatus*) from two isolated colonies in northern Norway showed a twofold increase from 1983 to 1993, followed by a levelling off up to 2003 [212]. PFCAs in the same samples also showed an increase from 1983 to 1993, followed either by a weak increase post 1993 ($n=9$ to 11) or a levelling off ($n=12$ and 13). These observed temporal trends suggest that sources of PFCs are likely to have changed over the last two decades [212].

References

1. Grondin, J., Sagnes, R., Commeyras, A. Perfluorosulfonic acids 3. Hammett acidity functions of perfluoroalkanesulfonic acids and of their mixtures with SBF_5 . *B. Soc. Chim. Fr.*, **11–12**: 1779–1782 (1976).
2. Tromp, T. K., Ko, M. K. W., Rodriguez, J. M., Sze, N. D. Potential accumulation of a CFC-replacement degradation product in seasonal wetlands. *Nature*, **376**: 327–330 (1995).
3. Boutonnet, J. C., Bingham, P., Calamari, D., de Rooij, C., Franklin, J., Kawano, T., *et al.* Environmental risk assessment of trifluoroacetic acid. *Hum. Ecol. Risk Assess.*, **5**: 59–124 (1999).
4. Kissa, E. *Fluorinated Surfactants, Synthesis, Properties, Applications*. Marcel Dekker, New York, 2001.
5. Moroi, Y., Yano, H., Shibata, O., Yonemitsu, T. Determination of acidity constants of perfluoroalkanoic acids. *Bull. Chem. Soc. Japan*, **74**: 667–672 (2001).
6. 3M Company. Fluorochemical use, distribution and release overview. US Environmental Protection Agency Public Docket AR-226-0550, St Paul, Minnesota, 1999.
7. Fluoropolymer Manufacturers Group. Detecting and quantifying low levels of fluoropolymer polymerization aids – a guidance document. Society of the Plastic Industry, Inc., Washington, DC, 2003.
8. DuPont. DuPont global PFOA strategy – comprehensive source reduction. Presentation to USEPA-OPPT, January 31, 2005. US Environmental Protection Agency Public Docket AR226-1914, Washington, DC, 2005.
9. Simons, J. H. The electrochemical process for the production of fluorocarbons. *J. Electrochem. Soc.*, **95**: 47–59 (1949).
10. 3M Company. Phase-out plan for PFOSF-based products. US Environmental Protection Agency Public Docket OPPT-2002-0043, St Paul, Minnesota, 2000.
11. Renner, R. The long and short of perfluorinated replacements. *Environ. Sci. Technol.*, **40**: 12–13 (2006).
12. Brace, N. O. (DuPont). Addition of Perfluoroalkyl Iodides to Unsaturated Compounds and Products Produced Thereby. US Patent Number 3145222, 1961.
13. Blanchard, W. A., Rhode, J. C. (DuPont). Process for Preparing Perfluoroalkyl Iodides. US Patent Number 3226449, 1965.
14. Prevedouros, K., Cousins, I. T., Buck, R. C., Korzeniowski, S. H. Sources, fate and transport of perfluorocarboxylates. *Environ. Sci. Technol.*, **40**: 32–44 (2006).
15. 3M Company. Environmental and health assessment of perfluorooctane sulfonate and its salts. US Environmental Protection Agency Public Docket AR-226-1486, St Paul, Minnesota, 2003.
16. 3M Company. Production of PFOS derivatives (email letter). US Environmental Protection Agency, AR-226-0997, Washington, DC, 2001.
17. Telomer Research Program. Telomer Research Program Update. Presented to USEPA-OPPT, November 25, 2002. US Environmental Protection Agency Public Docket AR226-1141, Washington, DC, 2002.

18. DuPont Global PFOA Strategy – comprehensive source reduction. Presentation to USEPA-OPPT, January 31, 2005. US Environmental Protection Agency Public Docket AR226-1914, Washington, DC, 2005.
19. Organisation for Economic Co-operation and Development (OECD). Results of the 2006 survey on production and use of PFOS, PFAS, PFOA, PFCA, their related substances and products/mixtures containing these substances. ENV/JM/MONO(2006)36, Environment Directorate, Organisation for Economic Co-operation and Development, Paris, 2006.
20. US Environmental Protection Agency. Perfluoroalkyl sulfonates, significant new use rule; final rule and supplemental proposed rule. *Fed. Regist.*, **67**: 11007–11013 (2002).
21. US Environmental Protection Agency. Toxic Substance Control Act (TSCA) Chemical Inventory, Washington, DC, 2002.
22. Lau, C., Buttenhoff, J. L., Rogers, J. M. The development toxicity of perfluoroalkyl acids and their derivative. *Toxicol. Appl. Pharmacol.*, **198**: 231–241 (2004).
23. Lau, C., Anitole, K., Hodes, C., Lai, D., Pfahles-Hutchens, A., Seed, J. Perfluoroalkyl acids: a review of monitoring and toxicological findings. *Toxicol. Sci.*, **99**: 366–394 (2007).
24. Kennedy, G. L., Butenhoff, J. L., Olsen, G. W., O'Connor, J. C., Seacat, A. M., Perkins, R. G., *et al.* The toxicology of perfluorooctanoate. *Crit. Rev. Toxicol.*, **34**: 351–384 (2004).
25. Hu, W., Jones, P. D., De Coen, W., Newsted, J. L., Giesy, J. P. Alterations in cell membrane properties caused by perfluorinated compounds. *Comp. Biochem. Physiol. C: Pharmacol.*, **135C**: 77–88 (2003).
26. Renner, R. Growing concern over perfluorinated chemicals. *Environ. Sci. Technol.*, **35**: 154A–160A (2001).
27. Jones, P. D., Hu, W., De Coen, W. Binding of perfluorinated fatty acids to serum proteins. *Environ. Toxicol. Chem.*, **22**: 2639–2649 (2003).
28. Han, X., Snow, T. A., Kemper, R. A., Jepson, G. W. Binding of perfluorooctanoic acid to rat and human plasma proteins. *Chem. Res. Toxicol.*, **16**: 775–781 (2003).
29. Van den Heuvel, J., Kuslikis, B., Van Rafelgham, M. Tissue distribution, metabolism, and elimination of perfluorooctanoic acid in male and female rats. *Biochem. Toxicol.*, **6**: 83–92 (1991).
30. Kudo, N., Katakura, M., Sato, Y., Kawashima, Y. Sex hormone-regulated renal transport of perfluorooctanoic acid. *Chem. Biol. Interac.*, **139**: 301–316 (2002).
31. Ikeda, T., Aiba, K., Fukuda, K., Tanaka, M. The induction of peroxisome proliferation in rat liver by perfluorinated fatty acids, metabolically inert derivatives of fatty acids. *J. Biochem.*, **98**: 475–482 (1985).
32. Sohlenius, A. K., Lundgren, B., Depierre, J. W. Perfluorooctanoic acids has persistent effects on peroxisome proliferation and related paramets in mouse liver. *J. Biochem. Toxicol.*, **7**: 205–212 (1992).
33. Sohlenius, A. K., Eriksson, A. M., Hogstrom, C., Kimland, M., Depierre, J. W. Perfluorooctane sulfonic acid is a potent inducer of peroxisomal fatty-acid beta-oxidation and other activities known to be affected by peroxisome proliferators in mouse liver. *Pharmacol. Toxicol.*, **72**: 90–93 (1993).
34. Intrasuksri, U., Feller, D. R. Comparison of the effects of selected monocarboxylic, dicarboxylic and perfluorinated fatty acids on peroxisome proliferation in primary cultured rat hepatocytes. *Biochem. Pharm.*, **42**: 184–188 (1991).
35. Biegel, L. B., Liu, R. C. M., Hurtt, M. E., Cook, J. C. Effects of ammonium perfluorooctanoate on Leydig cell function: *in vitro*, *in vivo* and *ex vivo* studies. *Toxicol. Appl. Pharmacol.*, **134**: 18–25 (1995).
36. Griffith, F. D., Long, J. E. Animal toxicity studies with ammonium perfluorooctanoate. *Am. Ind. Hygiene Ass. J.*, **41**: 576–583 (1980).
37. Upham, B. L., Deocamp, N. D., Wurl, B., Troskp, J. E. Inhibition of gap junction intercellular communication by perfluorinated fatty acids is dependent on the chain length of the fluorinated tail. *Int. J. Cancer*, **78**: 491–495 (1998).
38. Hu, W., Jones, P. D., Upham, B. L., Trosko, J. E., Lau, C., Giesy, J. P. Inhibition of gap junction intercellular communication by perfluorinated compounds in rate liver and dolphin

- kidney epithelial cell lines *in vitro* and Sprague–Dawley rates *in vivo*. *Toxicol. Sci.*, **68**: 429–436 (2002).
39. US Environmental Protection Agency. Draft risk assessment of potential human health effects associated with PFOA and its salts. US Environmental Protection Agency Public Docket SAB-06-006, Washington, DC, May 3, 2006.
 40. Kudo, N., Iwase, Y., Okayachi, H., Yamakawa, Y., Kawashima, Y. Induction of hepatic peroxisome proliferation by 8-2 telomer alcohol feeding in mice: formation of perfluorooctanoic acid in the liver. *Toxicol. Sci.*, **86**: 231–238 (2005).
 41. Ishibashi, H., Ishida, H., Matsuoka, M., Tominaga, N., Arizono, K. Estrogenic effects of fluorotelomer alcohols for human estrogen receptor isoforms alpha and beta *in vitro*. *Biol. Pharm. Bull.*, **30**: 1358–1359 (2007).
 42. Case, M. T., York, R. G., Christian, M. S. Rat and rabbit oral developmental toxicology studies with two perfluorinated compounds. *Int. J. Toxicol.*, **20**: 101–109 (2001).
 43. Berthiaume, J., Wallace, K. B. Perfluorooctanoate, perfluorooctanesulfonate, and *N*-ethyl perfluorooctanesulfonamido ethanol; peroxisome proliferation and mitochondrial biogenesis. *Toxicol. Lett.*, **129**: 23–32 (2002).
 44. Phillips, M. M., Dinglasan-Panlilio, M. J. A., Mabury, S. A., *et al.* Fluorotelomer acids are more toxic than perfluorinated acids. *Environ. Sci. Technol.*, **41**: 7159–7163. (2007).
 45. Key, B. D., Howell, R. D., Criddle, C. S. Fluorinated organics in the biosphere. *Environ. Sci. Technol.*, **31**: 2445–2454 (1991).
 46. Pauling, L. *The Nature of the Chemical Bond*. Cornell University Press, Ithaca, New York, 1960.
 47. Smart, B. E. Fluorine substituent effects (on bioactivity). *J. Fluorine Chem.*, **109**: 3–11 (2001).
 48. Smart, B. E. Fluorocarbons. In *The Chemistry of Functional Groups. The Chemistry of Halides, Pseudo Halides and Azides* (eds S. Patai and Z. Rappoport). John Wiley & Sons, Ltd, Chichester, 1983, pp. 603–655.
 49. Kirsch, P. *Modern Fluoroorganic Chemistry*. John Wiley & Sons Inc., New York, 2004.
 50. Key, B. D., Howell, R. D., Criddle, C. S. Fluorinated organics in the biosphere. *Environ. Sci. Technol.*, **31**: 2445–2454 (1997).
 51. Eaton, D. F., Smart, B. E. Are fluorocarbon chains stiffer than hydrocarbon chains?. *J. Am. Chem. Soc.*, **112**: 2821–2823 (1991).
 52. Bunn, C. W., Howells, E. R. Structures of molecules and crystals of fluorocarbons. *Nature*, **174**: 549–551 (1954).
 53. Wang, J., Ober, C. K. Solid state crystalline and liquid crystalline structure of semifluorinated 1-bromoalkane compounds. *Liq. Cryst.*, **26**: 637–648 (1999).
 54. Ellis, D. A., Denkenberger, K. A., Burrow, T. E., Mabury, S. A. The use of ¹⁹F NMR to interpret the structural properties of perfluorocarboxylate acids: a possible correlation with their environmental disposition. *J. Phys. Chem. A*, **108**: 10099–10106 (2004).
 55. Buchanan, G. W., Munteanu, E., Dawson, B. A., Hodgson, D. Concerning the origin of ¹⁹F-¹⁹F NMR COSY and NOESY connections in the spectra of perfluorooctanoic acid: RF-palmitic acid-F₁₃ and diethyl perfluorosuberate. *Mag. Res. Chem.*, **43**: 528–534. (2005).
 56. Von Werner, K., Wrackmeyer, B. ¹⁷O NMR study of polyfluorinated alcohols and ethers. *J. Fluorine Chem.*, **31**: 183–196 (1986).
 57. Napoli, M., Krotz, L., Scipioni, A., Seraglia, R., Traldi, P. Mass spectrometry of some C₆F₁₃-compounds and their C₆H₁₃-analogs. *Rapid Commun. Mass Sp.*, **7**: 789–794 (1993).
 58. Ellis, D. A., Mabury, S. A. Chemical ionization pathways of polyfluorinated chemicals – a connection to environmental atmospheric processes. *J. Am. Soc. Mass Spectrom.*, **14**: 1177–1191 (2003).
 59. Stock, N. L., Ellis, D. A., Deleebeeck, L., Muir, D. C. G., Mabury, S. A. Vapour pressures of the fluorinated telomer alcohols – limitations of estimation methods. *Environ. Sci. Technol.*, **38**: 1693–1699 (2004).
 60. Waterland, R. L., Hurley, M. D., Misner, J. A., Wallington, T. J., Melo, S. M. L., Strong, K., *et al.* Gas phase UV and IR adsorption spectra of CF₃CH₂CH₂OH and F(CF₂CF₂)_xCH₂CH₂OH (x = 2, 3, 4). *J. Fluorine Chem.*, **126**: 1288–1296 (2005).

61. Arp, H. P. H., Niederer, C., Goss, K.-U. Predicting the partitioning behaviour of various highly fluorinated compounds. *Environ. Sci. Technol.*, **40**: 7298–7304 (2006).
62. Gladysz, J. A., Curran, D. P., Horvath, I. T. (eds) *Handbook of Fluorous Chemistry*. John Wiley & Sons, Inc., New York, 2004.
63. Erkoc, S., Erkoc, F. Structural and electronic properties of PFOS and LiPFOS. *J. Molec. Structs–Theochem.*, **549**: 289–293 (2001).
64. Kaiser, M. A., Cobranchi, D. A., Chai Kao, C.-P., Krusic, J., Marchione, A. A., Buck, R. C. Physicochemical properties of 8-2 fluorinated telomer B alcohol. *J. Chem. Engng Data*, 912–916 (2004).
65. Liu, J., Lee, L. Solubility and sorption by soils of 8:2 fluorotelomer alcohol in water and cosolvent systems. *Environ. Sci. Technol.*, **39**: 7535–7540 (2005).
66. De Silva, A. O., Stock, N. L., Bonin, J. L., Wong, G. W.-Y., Mabury, S. A. Water solubility and octanol–water partition coefficient of perfluorooctylsulfonamides and fluorotelomer alcohols. *J. Chem. Eng. Data*, 2008 (to be submitted).
67. Prokop, H. W., Zhou, H.-J., Xu, S.-Q., Wu, C.-H., Liu, C. C. Analysis of the products from the electrochemical fluorination of octanoyl chloride. *J. Fluorine Chem.*, **43**: 277–290 (1989).
68. US Environmental Protection Agency. Draft hazard assessment of perfluorooctanoic acid and its salts. Office of Pollution Prevention and Toxics, Risk Assessment Division, Washington, DC, February 20, 2002.
69. Kauck, E. A., Diesslin, A. R. Some properties of perfluorocarboxylic acids. *Ind. Engng Chem.*, **43**: 2332–2334 (1951).
70. 3M Company. Sulfonated perfluorochemicals in the environment: sources, dispersion, fate and effects. US Environmental Protection Agency Public Docket AR-226-602, St Paul, Minnesota, 2000.
71. Lei, Y. D., Wania, F., Mathers, D., Mabury, S. A. Determination of vapor pressures, octanol–air, and water–air partition coefficients for polyfluorinated sulfonamide, sulfonamidoethanols, and telomer alcohols. *J. Chem. Engng Data*, **49**: 1013–1022 (2004).
72. Krusic, P. J., Marchione, A. A., Davidson, F., Kaiser, M. A., Kao, C.-P. C., Richardson, R. E., *et al.* Vapour pressures and intramolecular hydrogen bonding in fluorotelomer alcohols. *J. Phys. Chem. A*, **109**: 6232–6241 (2005).
73. Cobranchi, D. P., Botelho, M. W. B., Buck, R. C., Kaiser, M. A. Vapor pressure determinations of 8-2 fluorotelomer alcohol and 1-H perfluorooctane by capillary gas chromatography. Relative retention time versus headspace methods. *J. Chromatogr. A*, **1108**: 248–251 (2006).
74. Shoeib, M., Harner, T., Ikononou, M., Kannan, K. Indoor and outdoor air concentration and phase partitioning of perfluoroalkyl sulphonamides and polybrominated diphenyl ethers. *Environ. Sci. Technol.*, **38**: 1313–1320 (2004).
75. 3M Company. Determination of vapor pressure curve by dynamic method for U1463 (Et FOSE). US Environmental Protection Agency Public Docket AR226-346, Washington, DC, 1998.
76. Kaiser, M. A., Larsen, B. S., Kao, C.-P. C., Buck, R. C. Vapor pressures of perfluorooctanoic, -nonanoic, -decanoic, -undecanoic, and -dodecanoic acids. *J. Chem. Engng Data*, **50**: 1841–1843 (2005).
77. Goss, K.-U., Bronner, G., Harner, T., Hertel, M., Schmidt, T. C. The partition behaviour of fluorotelomer alcohols and olefins. *Environ. Sci. Technol.*, **40**: 3572–3577 (2006).
78. Li, H., Ellis, D. A., Mackay, D. Measurement of low air–water partition coefficients of organic acids by evaporation from a water surface. *J. Chem. Engng Data*, **52**: 1580–1584 (2007).
79. Sullivan, R. C., Mabury, S. A. Sorption of perfluorinated carboxylates and sulfonates to soil. Society of Environmental Toxicology and Chemistry (SETAC), Baltimore, Maryland, November 11–15, (2001).
80. Higgins, C. P., Luthy, R. G. Sorption of perfluorinated surfactants on sediments. *Environ. Sci. Technol.*, **40**: 7251–7256 (2006).
81. Muir, D. C. G., Smithwick, M., Brandsma, S., Bujas, T., Small, J. M., Martin, J. W., *et al.* Uptake, transformation and elimination of fluorotelomer alcohols and PFOSA by rainbow trout

- (*Oncorhynchus mykiss*). Society of Environmental Toxicology and Chemistry (SETAC), The Hague, The Netherlands, May 7–11, (2006).
82. Furdui, V. I., Stock, N. L., Ellis, D. A., Butt, C., Whittle, D. M., Crozier, P. W., *et al.* Perfluoroalkyl contaminants in lake trout from the Great Lakes. *Environ. Sci. Technol.*, **41**: 1554–1559 (2007).
 83. Martin, J. W., Mabury, S. A., Solomon, K., Muir, D. C. G. Dietary accumulation and tissue distribution of perfluorinated acids in juvenile rainbow trout (*Oncorhynchus mykiss*). *Environ. Toxicol. Chem.*, **22**: 189–195 (2003).
 84. Martin, J., Mabury, S., Solomon, K., Muir, D. Bioconcentration and tissue distribution of perfluorinated acids in rainbow trout (*Oncorhynchus mykiss*). *Environ. Toxicol. Chem.*, **22**: 196–204 (2003).
 85. Moody, C. A., Martin, J. W., Kwan, W. C., Muir, D. C. G., Mabury, S. A. Monitoring perfluorinated surfactants in biota and surface water samples following an accidental release of fire-fighting foam into Etobicoke Creek. *Environ. Sci. Technol.*, **36**: 545–551 (2002).
 86. Taniyasu, S., Kannan, K., Horii, Y., Hanari, N., Yamashita, N. A survey of perfluorooctane sulfonate and related perfluorinated organic compounds in water, fish, birds, and humans from Japan. *Environ. Sci. Technol.*, **37**: 2634–2639 (2003).
 87. Tomy, G. T., Budakowski, W., Halldorson, T., Helm, P. A., Stern, G. A., Friesen, K., *et al.* Fluorinated organic compounds in an Eastern Arctic marine food web. *Environ. Sci. Technol.*, **38**: 6475–6481 (2004).
 88. Kannan, K., Tao, L., Sinclair, E., Pastva, S. D., Jude, D. J., Giesy, J. P. Perfluorinated compounds in aquatic organisms at various trophic levels in a Great Lakes food chain. *Arch. Environ. Contam. Toxicol.*, **48**: 559–566 (2005).
 89. Houde, M., Bujas, T. A. D., Small, J. M., Wells, R. S., Fair, P. A., Bossart, G. D., *et al.* Biomagnification of perfluoroalkyl compounds in the bottlenose dolphin (*Tursiops truncatus*) food web. *Environ. Sci. Technol.*, **40**: 4138–4144 (2006).
 90. Moody, C. A., Field, J. A. Determination of perfluorocarboxylates in groundwater impacted by fire-fighting activity. *Environ. Sci. Technol.*, **33**: 2800–2806 (1999).
 91. Boudreau, T. M., Wilson, C. J., Cheong, W. J., Sibley, P. K., Mabury, S. A., Muir, D. C. G., *et al.* Response of the zooplankton community and environmental fate of perfluorooctane sulfonic acid in aquatic microcosms. *Environ. Toxicol. Chem.*, **22**: 2739–2745 (2003).
 92. Hanson, M. L., Small, J. M., Sibley, P. K., Boudreau, T. M., Brain, R. A., Mabury, S. A., *et al.* Microcosm evaluation of the fate, toxicity, and risk to aquatic macrophytes from perfluorooctanoic acid (PFOA). *Arch. Environ. Contam. Toxicol.*, **49**: 307–316 (2005).
 93. van Leeuwen, S., Karrman, A., van Bavel, B., de Boer, J., Lindstrom, G. Struggle for quality and determination of perfluorinated contaminants in environmental and human samples. *Environ. Sci. Technol.*, **40**: 7854–7860 (2006).
 94. Martin, J. W., Kannan, K., Berger, U., de Voogt, P., Field, J. A., Franklin, J., *et al.* Analytical challenges hamper perfluoroalkyl research. *Environ. Sci. Technol.*, **38**: 248A–255A (2004).
 95. Yamashita, N., Kannan, K., Taniyasu, S., Horii, Y., Okazawa, T., Petrick, G., *et al.* Analysis of perfluorinated acids at parts-per-quadrillion levels in seawater using liquid chromatography–tandem mass spectrometry. *Environ. Sci. Technol.*, **38**: 5522–5528 (2004).
 96. Villagrasa, M., Lopez de Alda, M., Barcelo, D. Environmental analysis of fluorinated alkyl substances by liquid chromatography–(tandem) mass spectrometry: a review. *Anal. Bioanal. Chem.*, **386**: 953–972 (2006).
 97. van Leeuwen, S., de Boer, J. Extraction and clean-up strategies for the analysis of poly- and perfluoroalkyl substances in environmental and human matrices. *J. Chromatogr. A.*, **1153**: 172–185 (2007).
 98. Schultz, M. M., Barofsky, D. F., Field, J. A. Quantitative determination of fluorotelomer sulfonates in groundwater by LC-MS/MS. *Environ. Sci. Technol.*, **38**: 1828–1835 (2004).
 99. Martin, J. W., Muir, D. G. C., Moody, C. A., Ellis, D. A., Kwan, W. C., Solomon, K. R., *et al.* Collection of airborne fluorinated organics and analysis by gas chromatography/chemical ionization mass spectrometry. *Anal. Chem.*, **74**: 584–590 (2002).

100. Stock, N. L., Lau, F. K., Ellis, D. A., Martin, J. W., Muir, D. G. C., Mabury, S. A. Polyfluorinated telomer alcohols and sulfonamides in the North American troposphere. *Environ. Sci. Technol.*, **38**: 991–996 (2004).
101. Shoeib, M., Harner, T., Vlahos, P. Perfluorinated chemicals in the arctic atmosphere. *Environ. Sci. Technol.*, **40**: 7577–7583 (2006).
102. Jahnke, A., Ahrens, L., Ebinghaus, R., Berger, U., Barber, J. L., Temme, C. An improved method for the analysis of volatile polyfluorinated alkyl substances in environmental air samples. *Anal. Bioanal. Chem.*, **387**: 965–975 (2007).
103. Dinglasan, M. J. A., Ye, Y., Mabury, S. A., Edwards, E. A. Fluorotelomer alcohol biodegradation yields poly- and perfluorinated acids. *Environ. Sci. Technol.*, **38**: 2857–2864 (2004).
104. Wang, N., Szostek, B., Buck, R. C., Folsom, P. W., Sulecki, M., Capka, V., *et al.* Fluorotelomer alcohol biodegradation – direct evidence that perfluorinated carbon chain breaks down. *Environ. Sci. Technol.*, **39**: 7516–7528 (2005).
105. Hansen, K., Clemen, L., Ellefson, M., Johnson, H. Compound specific quantitative characterization of organic fluorochemicals in biological matrices. *Environ. Sci. Technol.*, **35**: 766–770 (2001).
106. Giesy, J., Kannan, K. Global distribution of perfluorooctane sulfonate in wildlife. *Environ. Sci. Technol.*, **35**: 1339–1342 (2001).
107. Butt, C. M., Muir, D. C. G., Stirling, I., Kwan, M., Mabury, S. A. Rapid response of arctic ringed seals to changes in perfluoroalkyl production. *Environ. Sci. Technol.*, **41**: 42–49 (2007).
108. Kannan, K., Corsolini, S., Falandysz, J., Fillmann, G., Kumar, K. S., Loganathan, B. G., *et al.* Perfluorooctane sulfonate and related fluorochemicals in human blood from several countries. *Environ. Sci. Technol.*, **38**: 4489–4495 (2004).
109. Martin, J. W., Whittle, D. M., Muir, D. G. C., Mabury, S. A. Perfluoroalkyl contaminants in a food web from Lake Ontario. *Environ. Sci. Technol.*, **38**: 5379–5385 (2004).
110. Hansen, K. J., Johnson, H. O., Eldridge, J. S., Butenhoff, J. L., Dick, L. A. Quantitative characterization of trace levels of PFOS and PFOA in the Tennessee River. *Environ. Sci. Technol.*, **36**: 1681–1685 (2002).
111. de Voogt, P., Saez, M. Analytical chemistry of perfluoroalkylated substances. *TrAC*, **25**: 326–342 (2006).
112. Yamashita, N., Kannan, K., Taniyasu, S., Horii, Y., Petrick, G., Gamo, T. A global survey of perfluorinated acids in oceans. *Mar. Pollut. Bull.*, **51**: 658–668 (2005).
113. Young, C., Furdui, V. I., Franklin, J., Koerner, R. M., Muir, D. C. G., Mabury, S. A. Perfluorinated acids in arctic snow: new evidence for atmospheric formation. *Environ. Sci. Technol.*, **41**: 3455–3461 (2007).
114. Furdui, V. I., Crozier, P. W., Reiner, E. J., Mabury, S. A. Optimized trace level analysis of perfluorinated carboxylic and sulfonic acids. *Organohalogen Cpd.*, 211–214 (2005).
115. Schroeder, H. Determination of fluorinated surfactants and their metabolites in sewage sludge samples by liquid chromatography with mass spectrometry and tandem mass spectrometry after pressurized liquid extraction and separation on fluorine-modified reversed-phase sorbents. *J. Chromatogr. A*, **1020**: 131–151 (2003).
116. Langlois, I., Oehme, M. Structural identification of isomers present in technical perfluorooctane sulfonate by tandem mass spectrometry. *Rapid Commun. Mass Sp.*, **20**: 844–850 (2006).
117. Benskin, J. P., Bataineh, M., Martin, J. W. Simultaneous characterization of perfluoroalkyl carboxylate, sulfonate and sulfonamide isomers by liquid chromatography–tandem mass spectrometry. *Anal. Chem.*, **79**: 6455–6464 (2007).
118. Boulanger, B., Peck, A. M., Schoor, J. L., Hornbuckle, C. K. Mass budget of perfluorooctane surfactants in Lake Ontario. *Environ. Sci. Technol.*, **39**: 74–79 (2005).
119. De Silva, A. O., Mabury, S. A. Isolating isomers of perfluorocarboxylates in polar bears (*Ursus maritimus*) from two geographical locations. *Environ. Sci. Technol.*, **38**: 6538–6545 (2004).
120. De Silva, A. O., Mabury, S. A. Isomer distribution of perfluorocarboxylates in human blood: potential correlation to source. *Environ. Sci. Technol.*, **40**: 2903–2909 (2006).

121. Scott, B. F., Moody, C. A., Spencer, C., Small, J. M., Muir, D. C. G., Mabury, S. A. Analysis for perfluorocarboxylic acids/anions in surface waters and precipitation using GC/MS and analysis of PFOS from large volume samples. *Environ Sci Technol.*, **40**: 6405–6410 (2006).
122. Scott, B. F., Spencer, C., Mabury, S. A., Muir, D. C. G. Poly and perfluorinated carboxylates in North American precipitation. *Environ. Sci. Technol.*, **40**: 7167–7173 (2006).
123. Taves, D. R. Evidence that there are two forms of fluoride in human serum. *Nature*, **16**: 1050–1051 (1968).
124. Moody, C. A., Kwan, W. C., Martin, J. W., Muir, D. C. G., Mabury, S. A. Determination of perfluorinated surfactants in surface water samples by two independent analytical techniques: liquid chromatography/tandem mass spectrometry and ¹⁹F NMR. *Anal. Chem.*, **73**: 2200–2206 (2001).
125. Wickbold, R. Die photometrische trubunoptitration zur bestimmung kleinster sulfatmengen. *Agnew. Chem.*, **66**: 173 (1954).
126. Miyake, Y., Yamashita, N., Rostkowski, P., So, M. K., Taniyasu, S., Lam, P. K. S., *et al.* Determination of trace levels of total fluorine in water using combustion ion chromatography for fluorine: a mass balance approach to determine individual perfluorinated chemicals in water. *J. Chromatogr. A*, **1143**: 98–104 (2007).
127. Miyake, Y., Yamashita, N., So, M. K., Rostkowski, P., Taniyasu, S., Lam, P. K. S., *et al.* Trace analysis of total fluorine in human blood using combustion ion chromatography for fluorine: a mass balance approach for the determination of known and unknown organofluorine compounds. *J. Chromatogr. A*, **1154**: 214–221 (2007).
128. Arsenault, G., Chittim, B., McAlees, A., McCrindle, R., Riddell, N., Yeo, B. Some issues relating to the use of perfluorooctanesulfonate (PFOS) samples as references standards. *Chemosphere*, **70**: 616–625 (2008).
129. Olsen, G. W., Church, T. R., Miller, J. P., Hansen, K. J., Lundberg, J. K., Armitage, J. M., *et al.* Perfluorooctanesulfonate and other fluorochemicals in the serum of American Red Cross adult blood donors. *Environ. Health Perspect.*, **111**: 1892–1901 (2003).
130. Olsen, G. W., Huang, H.-Y., Helzlsouer, K. J., Hansen, K. J., Butenhoff, J. L., Mandel, J. H. Historical comparison of perfluorooctanesulfonate, perfluorooctanoate and other fluorochemicals in human blood. *Environ. Health Perspect.*, **113**: 539–545 (2005).
131. Guruge, K. S., Taniyasu, S., Yamashita, N., Wijeratna, S., Mohotti, K. M., Seneviratne, H. R., *et al.* Perfluorinated organic compounds in human blood serum and seminal plasma: a study of urban and rural tea worker populations in Sri Lanka. *J. Environ. Monitor*, **7**: 371–377 (2005).
132. Yeung, L. W. Y., So, M. K., Jiang, G., Taniyasu, S., Yamashita, N., Song, M., *et al.* Perfluorooctanesulfonate and related fluorochemicals in human blood samples from China. *Environ. Sci. Technol.*, **40**: 715–720 (2006).
133. Calafat, A. M., Kuklenyik, Z., Caudill, S. P., Reddy, J. A., Needham, L. L. Perfluorochemicals in pooled serum samples from United States residents in 2001 and 2002. *Environ. Sci. Technol.*, **40**: 2128–2134 (2006).
134. Olsen G.W. Schmickler M.N. Tierens J.M. Logan P.W. Burris J.M. Burlew M.M., *et al.* Descriptive summary of serum fluorochemical levels among employee participants of the year 2000 Antwerp Fluorochemical Medical Surveillance Program. US Environmental Protection Agency Public Docket AR-226-1030-0206, St Paul, Minnesota 2001.
135. Olsen, G. W., Burris, J. M., Ehresman, D. J., Froehlich, J. W., Seacat, A. M., Butenhoff, J. L., *et al.* Half-life of serum elimination of perfluorooctanesulfonate, perfluorohexanesulfonate, and perfluorooctanoate in retired fluorochemical production workers. *Environ. Health Perspect.*, **115**: 1298–1305 (2007).
136. Houde, M., Martin, J. W., Letcher, R., Solomon, K., Muir, D. C. G. Biological monitoring of perfluoroalkyl substances: a review. *Environ. Sci. Technol.*, **40**: 3463–3473 (2006).
137. Inoue, K., Okada, F., Ito, R., Kato, S., Sasaki, S., Nakajima, S., *et al.* Perfluorooctane sulfonate (PFOS) and related perfluorinated compounds in human blood and cord blood samples: assessment of PFOS exposure in a susceptible population during pregnancy. *Environ. Health Perspect.*, **112**: 1204–1207 (2004).

138. So, M. K., Yamashita, N., Taniyasu, S., Jiang, Q., Giesy, J. P., Chen, K., *et al.* Health risks in infants associated with exposure to perfluorinated compounds in human breastmilk from Zhoushan. *China. Environ. Sci. Technol.*, **40**: 2924–2929 (2006).
139. Tittlemier, S. A., Pepper, K., Seymour, C., Moisey, J., Bronson, R., Cao, X.-L., *et al.* Dietary exposure of Canadians to perfluorinated carboxylates and perfluorooctane sulfonate via consumption of meat, fish, fast foods and food items prepared in their packaging. *J. Agric. Food Chem.*, **55**: 3203–3210 (2007).
140. Washburn, S. T., Bingman, T. S., Braithwaite, S. K., Buck, R. C., Buxton, L. W., Clewell, H. J., *et al.* Exposure assessment and risk characterization for perfluorooctanoate in selected consumer articles. *Environ. Sci. Technol.*, **39**: 3904 (2005).
141. Dinglasan-Panlilio, M. J. A., Mabury, S. A. Significant residual fluorinated alcohols present in various fluorinated materials. *Environ. Sci. Technol.*, **40**: 1447–1453 (2006).
142. Larsen, B. S., Stchur, P., Szostek, B., Bachmura, S. F., Rowand, R. C., Prickett, K. B., *et al.* Method development for the determination of residual fluorotelomer raw material and perfluorooctanoate in fluorotelomer-based products by gas chromatography and liquid chromatography mass spectrometry. *J. Chromatogr. A*, **1110**: 117–124 (2006).
143. Begley, T. H., White, K., Honigfort, P., Twaroski, M. L., Neches, R., Walker, R. A. Perfluorochemicals: potential sources of and migration from food packaging. *Food Addit. Contam.*, **22**: 1023–1031 (2005).
144. Tittlemier, S. A., Pepper, K., Edwards, L. Concentrations of perfluorooctanesulfonamides in Canadian total diet study composite food samples collected between 1992 and 2004. *J. Agric. Food Chem.*, **54**: 8385–8389 (2006).
145. Falandysz, J., Taniyasu, S., Gulkowska, A., Yamashita, N. Is fish a major source of fluorinated surfactants and repellents in humans living on the Baltic Coast? *Environ. Sci. Technol.*, **40**: 748–751 (2006).
146. D'eon, J. C., Mabury, S. A. Production of perfluorinated carboxylic acids (PFCAs) from the biotransformation of polyfluoroalkyl phosphate surfactants (PAPS): exploring routes of human contamination. *Environ. Sci. Technol.*, **41**: 4799–4805 (2007).
147. Loveless, S. E., Finlay, C., Everds, N. E., Frame, S. R., Gillies, P. J., O'Connor, J. C., *et al.* Comparative responses of rats and mice exposed to linear/branched, linear, or branched ammonium perfluorooctanoate (APFO). *Toxicol.*, **220**: 203–216 (2006).
148. Hekster, F. M., Laane, R. W. P. M., de Voogt, P. Environmental and toxicity effects of perfluoroalkylated substances. *Rev. Environ. Contam. Toxicol.*, **179**: 99–121 (2003).
149. Dinglasan-Panlilio, M. J. A., Edwards, E., Mabury, S. A. Biodegradation of fluorotelomer monomers – importance of linkages. Presented at the Society of Environmental Toxicology and Chemistry (SETAC), Annual North American Meeting, Montreal, Quebec, Canada, November 5–9, 2006.
150. Telomer Research Program. Letter of Intent. US Environmental Protection Agency Public Docket OPPT 2003-0012-0013, Washington, DC, 2003.
151. Ellis, D. A., Mabury, S. A., Martin, J. W., Muir, D. G. C. Thermolysis of fluoropolymers as a potential source of halogenated organic acids in the environment. *Nature*, **412**: 321–324 (2001).
152. Ellis, D. A., Martin, J. W., Muir, D. G. C., Mabury, S. A. The use of ¹⁹F NMR and mass spectrometry for the elucidation of novel fluorinated acids and atmospheric fluoroacid precursors evolved in the thermolysis of fluoropolymers. *Analyst*, **128**: 756–764 (2003).
153. Ellis, D. A., Martin, J. W., DeSilva, A. O., Mabury, S. A., Hurley, M. D., Sulbeck Andersen, M. D., *et al.* Degradation of fluorotelomer alcohols: a likely source of perfluorinated carboxylic acids. *Environ. Sci. Technol.*, **38**: 3316–3321 (2004).
154. Wallington, T. J., Hurley, M. D., Xia, J., Wuebbles, D. J., Sillman, S., Ito, A., *et al.* Formation of C₇F₁₅COOH (PFOA) and other perfluorocarboxylic acids during the atmospheric oxidation of 8:2 fluorotelomer alcohol. *Environ. Sci. Technol.*, **40**: 924–930 (2006).
155. Gauthier, S. A., Mabury, S. A. Aqueous photolysis of 8:2 fluorotelomer alcohol. *Environ. Toxicol. Chem.*, **24**: 1837–1846 (2005).
156. Hagen, D. F., Belisle, J., Johnson, J. D., Venkateswarlu, P. Characterization of fluorinated metabolites by a gas chromatographic–helium microwave plasma detector – the biotransfor-

- mation of 1H, 1H, 2H, 2H-perfluorodecanol to perfluorooctanoate. *Anal. Biochem.*, **118**: 336–343 (1981).
157. Martin, J. W., Mabury, S. A., O'Brien, P. J. Metabolic products and pathways of fluorotelomer alcohols in isolated rat hepatocytes. *Chem. Biol. Interac.*, **155**: 165–180 (2005).
 158. Xu, L., Krenitsky, D. M., Seacat, A. M., Butenhoff, J. L., Anders, M. W. Biotransformation of *N*-ethyl-*N*-(2-hydroxyethyl)perfluorooctanesulfonamide by rat liver microsomes, cytosol, and slices and by expressed rat and human cytochromes P450. *Chem. Res. Toxicol.*, **17**: 767–775 (2004).
 159. Tomy, G. T., Tittlemier, S. A., Palace, V. P., Budakowski, W. R., Braekevelt, E., Brinkworth, L., *et al.* Biotransformation of *N*-ethyl perfluorooctane sulfonamide by rainbow trout (*Onchorhynchus mykiss*) liver microsomes. *Environ. Sci. Technol.*, **38**: 758–762 (2004).
 160. Martin, J. W., Ellis, D. A., Mabury, S. A., Hurley, M. D., Wallington, T. J. Atmospheric chemistry of perfluoroalkanesulfonamides: kinetic and product studies of the OH radical and Cl atom initiated oxidation of *N*-ethyl perfluorobutanesulfonamide. *Environ. Sci. Technol.*, **40**: 864–872 (2006).
 161. D'eon, J. C., Hurley, M. D., Wallington, T. J., Mabury, S. A. Atmospheric chemistry of *N*-methyl perfluorobutane sulfonamidoethanol. C₄F₉SO₂N(CH₃)CH₂CH₂OH: kinetics and mechanism of reaction with OH. *Environ. Sci. Technol.*, **40**: 1862–1868 (2006).
 162. Ellis, D. A., Martin, J. W., Mabury, S. A., Hurley, M. D., Sulbeck Andersen, M. D., Wallington, T. J. Atmospheric lifetime of fluorotelomer alcohols. *Environ. Sci. Technol.*, **37**: 3816–3820 (2003).
 163. Armitage, J., Cousins, I. T., Buck, R. C., Prevedouros, K., Russell, M. H., Macleod, M., *et al.* Modeling global-scale fate and transport of perfluorooctanoate from direct sources. *Environ. Sci. Technol.*, **40**: 6969–6975 (2006).
 164. Wania, F. A global mass balance analysis of the source of perfluorocarboxylic acids in the Arctic Ocean. *Environ. Sci. Technol.*, **41**: 4529–4535 (2007).
 165. So, M. K., Taniyasu, S., Yamashita, N., Giesy, J. P., Zheng, J., Fang, Z., *et al.* Perfluorinated compounds in coastal waters of Hong Kong, south China and Korea. *Environ. Sci. Technol.*, **38**: 4056–4063 (2004).
 166. Stock, N. L., Furdul, V. I., Muir, D. C. G., Mabury, S. A. Perfluoroalkyl contaminants in the Canadian Arctic: evidence of atmospheric transport and local contamination. *Environ. Sci. Technol.*, **41**: 3529–3536 (2007).
 167. Shoeib, M., Harner, T., Wilford, B. H., Jones, K. C., Zhu, J. Perfluorinated sulfonamides in indoor and outdoor air and indoor dust: occurrence, partitioning, and human exposure. *Environ. Sci. Technol.*, **39**: 6599–6606 (2005).
 168. Berger, U., Barber, J. L., Jahnke, A., Temme, C., Jones, K. C. Analysis of fluorinated alkyl compounds in air samples from England. In *Fluoros: An International Symposium on Fluorinated Organics in the Environment*, Toronto, Ontario, Canada, August 18–19, 2005.
 169. Jahnke, A., Ahrens, L., Ebinghaus, R., Temme, C. Urban versus remote air concentrations of fluorotelomer alcohols and other polyfluorinated alkyl substances in Germany. *Environ. Sci. Technol.*, **41**: 745–752 (2007).
 170. Sasaki, K., Harada, K., Saito, N., Tsutsui, T., Nakanishi, S., Tsuzuki, H., *et al.* Impacts of air-borne perfluorooctane sulfonate on the human body burden and the ecological system. *Bull. Environ. Contam. Toxicol.*, **71**: 408–413 (2003).
 171. Barton, C. A., Butler, L. E., Zarzecki, C. J., Flaherty, J., Kaiser, M. Characterizing perfluorooctanoate in ambient air near the fence line of a manufacturing facility: comparing modeled and monitored values. *J. Air Waste Managmt Ass.*, **56**: 48–55 (2006).
 172. Loewen, M., Halldorson, T., Wong, F., Tomy, G. Fluorotelomer carboxylic acids and PFOS in rainwater from an urban centre in Canada. *Environ. Sci. Technol.*, **39**: 2944–2951 (2005).
 173. Moody, C. A., Field, J. A. Perfluorinated surfactants and the environmental implications of their use in fire-fighting foams. *Environ. Sci. Technol.*, **34**: 3864–3870 (2000).
 174. Moody, C. A., Herbert, G. N., Strauss, S. H., Field, J. A. Occurrence and persistence of perfluorooctanesulfonate and other perfluorinated surfactants in groundwater at a fire-

- training area at Wurtsmith Air Force Base, Michigan. *USA. J. Environ. Monitor*, **5**: 341–345 (2003).
175. Saito, N., Sasaki, K., Nakatome, K., Harada, K., Yoshinaga, T., Koizumi, A. Perfluorooctane sulfonate concentrations in surface water in Japan. *Arch. Environ. Contam. Toxicol.*, **45**: 149–158 (2003).
176. Saito, N., Harada, K., Inoue, K., Sasaki, K., Yoshinaga, T., Koizumi, A. Perfluorooctanoate and perfluorooctane sulfonate concentrations in surface water in Japan. *J. Occup. Health.*, **46**: 49–59 (2004).
177. Tseng, C.-L., Liu, L.-L., Chen, C.-M., Ding, W.-H. Analysis of perfluorooctanesulfonate and related fluorochemicals in water and biological tissue samples by liquid chromatography–ion trap mass spectrometry. *J. Chromatogr. A*, **1105**: 119–126 (2006).
178. Skutlarek, D., Exner, M., Farber, H. Perfluorinated surfactants in surface and drinking waters. *Environ. Sci. Pollut. Res.*, **13**: 299–307 (2006).
179. Boulanger, B., Vargo, J., Schnoor, J., Hornbuckle, K. C. Detection of perfluorooctane surfactants in Great Lakes water. *Environ. Sci. Technol.*, **38**: 4064–4070 (2004).
180. Simcik, M. F., Dorweiler, K. J. Ratio of perfluorochemical concentrations as a tracer of atmospheric deposition to waters. *Environ. Sci. Technol.*, **39**: 8678–8683 (2005).
181. Sinclair, E., Mayack, D. T., Roblee, K., Yamashita, N., Kannan, K. Occurrence of perfluoroalkyl surfactants in water, fish and birds from New York State. *Arch. Environ. Contam. Toxicol.*, **50**: 398–410 (2006).
182. Taniyasu, S., Kannan, K., So, M. K., Gulkowska, A., Sinclair, E., Okazawa, T., *et al.* Analysis of fluorotelomer alcohols, fluorotelomer acids, and short- and long-chain perfluorinated acids in water and biota. *J. Chromatogr. A*, **1093**: 89–97 (2005).
183. Field, J. A., Simonich, S., Barfosky, D. Comment on 'Detection of perfluorooctane surfactants in Great Lakes water' and 'Mass budget of perfluorooctane surfactants in Lake Ontario'. *Environ. Sci. Technol.*, **39**: 3883–3884 (2005).
184. Szostek, B., Prickett, K. B., Buck, R. C. Determination of fluorotelomer alcohols by liquid chromatography/tandem mass spectrometry in water. *Rapid Commun. Mass Spectrom.*, **20**: 2837–2844 (2006).
185. Higgins, C. P., Field, J. A., Criddle, C. S., Luthy, R. G. Quantitative determination of perfluorochemicals in sediment and domestic sludge. *Environ. Sci. Technol.*, **39**: 3946–3956 (2005).
186. Nakata, H., Kannan, K., Nasu, T., Cho, H.-S., Sinclair, E., Takemura, A. Perfluorinated contaminants in sediments and aquatic organisms collected from shallow water and tidal flat areas of the Ariake Sea. Japan: environmental fate of perfluorooctane sulfonate in aquatic ecosystems. *Environ. Sci. Technol.*, **40**: 4916–4921 (2006).
187. Martin, J. W., Smithwick, M., Braune, B. M., Hoekstra, P. F., Muir, D. C. G., Mabury, S. A. Identification of long-chain perfluorinated acids in biota from the Canadian Arctic. *Environ. Sci. Technol.*, **38**: 373–380 (2004).
188. Kannan, K., Hansen, K. J., Wade, T. L., Giesy, J. P. Perfluorooctane sulfonate in oysters, *Crassostrea virginica*, from the Gulf of Mexico and the Chesapeake Bay. *Arch. Environ. Contam. Toxicol.*, **42**: 313–318 (2002).
189. Van de Vijver, K. I., Hoff, P. T., Van Dongen, W., Esmans, E. L., Blust, R., De Coen, W. Exposure patterns of perfluorooctane sulfonate in aquatic invertebrates from the Western Scheldt Estuary and the southern North Sea. *Environ. Toxicol. Chem.*, **22**: 2037–2041 (2003).
190. Kannan, K., Corsolini, S., Falandysz, J., Oehme, G., Focardi, S., Giesy, J. P. Perfluorooctane-sulfonate and related fluorinated hydrocarbons in marine mammals, fishes and birds from coasts of the Baltic and Mediterranean Seas. *Environ. Sci. Technol.*, **36**: 3210–3216 (2002).
191. Hoff, P. T., Van Campenhout, K., Van de Vijver, K., Covaci, A., Bervoets, L., Moens, L., *et al.* Perfluorooctane sulfonic acid and organohalogen pollutants in liver of three freshwater fish species in Flanders (Belgium): relationship with biochemical and organismal effects. *Environ. Pollut.*, **137**: 324–333 (2005).

192. Bossi, R., Riget, F. F., Dietz, R., Sonne, C., Fauser, P., Dam, M., *et al.* Preliminary screening of perfluorooctane sulfonate (PFOS) and other fluorochemicals in fish, birds and marine mammals from Greenland and the Faroe Island. *Environ. Pollut.*, **136**: 323–329 (2005).
193. Keller, J. M., Kannan, K., Taniyasu, S., Yamashita, N., Day, R. D., Arendt, M. D., *et al.* Perfluorinated compounds in the plasma of loggerhead and Kemp's ridley sea turtles from the southeastern coast of the United States. *Environ. Sci. Technol.*, **39**: 9101–9108 (2005).
194. Kannan, K., Franson, J. C., Bowerman, W. W., Hansen, K. J., Jones, P. D., Giesy, J. P. Perfluorooctane sulfonate in fish-eating water birds including bald eagles and albatrosses. *Environ. Sci. Technol.*, **35**: 3065–3070 (2001).
195. Kannan, K., Choi, J.-W., Iseki, N., Senthilkumar, K., Kim, D. H., Masunaga, S., *et al.* Concentrations of perfluorinated acids in livers of birds from Japan and Korea. *Chemosphere*, **49**: 225–231 (2002).
196. Verreault, J., Houde, M., Gabrielsen, G. W., Berger, U., Haukas, M., Letcher, R., *et al.* Perfluorinated alkyl substances in plasma, liver, brain, and eggs of glaucous gulls (*Larus hyperboreus*) from the Norwegian Arctic. *Environ. Sci. Technol.*, **39**: 7439–7444 (2005).
197. Butt, C. M., Mabury, S. A., Muir, D. C. G., Braune, B. M. Temporal trends of perfluorinated alkyl compounds in seabirds from the Canadian Arctic: prevalence of long-chained perfluorinated carboxylates. *Environ. Sci. Technol.*, **41**: 3521–3528 (2007).
198. Hoff, P. T., Scheirs, J., Van de Vijver, K., Van Dongen, W., Esmans, E. L., Blust, R., *et al.* Biochemical effect evaluation of perfluorooctane sulfonic acid-contaminated wood mice (*Apodemus sylvaticus*). *Environ. Health Perspect.*, **112**: 681–686 (2004).
199. Kannan, K., Koistinen, J., Beckmen, K., Evans, T., Gorzelany, J., Hansen, K., *et al.* Accumulation of perfluorooctane sulfonate in marine mammals. *Environ. Sci. Technol.*, **35**: 1593–1598 (2001).
200. Van de Vijver, K. I., Hoff, P. T., Das, K., Van Dongen, W., Esmans, E. L., Jauniaux, T., *et al.* Perfluorinated chemicals infiltrate ocean waters: link between exposure levels and stable isotope ratios in marine mammals. *Environ. Sci. Technol.*, **37**: 5545–5550 (2003).
201. Van de Vijver, K., Hoff, P. T., Das, K., Van Dongen, W., Esmans, E. L., Siebert, U., *et al.* Baseline study of perfluorochemicals in harbour porpoises (*Phocoena phocoena*) from Northern Europe. *Mar. Pollut. Bull.*, **48**: 992–999 (2004).
202. Bossi, R., Riget, F. F., Dietz, R. Temporal and spatial trends of perfluorinated compounds in ringed seal (*Phoca hispida*) from Greenland. *Environ. Sci. Technol.*, **39**: 7416–7422 (2005).
203. Houde, M., Wells, R. S., Fair, P. A., Bossart, G. D., Hohn, A. A., Rowles, T. K., *et al.* Polyfluorinated compounds in free-ranging bottlenose dolphins (*Tursiops truncatus*) from the Gulf of Mexico and the Atlantic Ocean. *Environ. Sci. Technol.*, **39**: 6591–6598 (2005).
204. Smithwick, M., Mabury, S. A., Solomon, K., Sonne, C., Martin, J. W., Born, E. W., *et al.* Circumpolar study of perfluoroalkyl contaminants in polar bears (*Ursus maritimus*). *Environ. Sci. Technol.*, **39**: 5517–5523 (2005).
205. Smithwick, M., Muir, D. C. G., Mabury, S. A., Solomon, K., Martin, J. W., Sonne, C., *et al.* Perfluoroalkyl contaminants in liver tissue from East Greenland polar bears (*Ursus maritimus*). *Environ. Tox. Chem.*, **24**: 981–986 (2005).
206. Kannan, K., Yun, S. H., Evans, T. J. Chlorinated, brominated, and perfluorinated contaminants in livers of polar bears from Alaska. *Environ. Sci. Technol.*, **39**: 9057–9063 (2005).
207. Houde, M., Balmer, B. C., Brandsma, S., Wells, R. S., Rowles, T. K., Solomon, K., *et al.* Perfluorinated alkyl compounds in relation with life-history and reproductive parameters in bottlenose dolphins (*Tursiops truncatus*) from Sarasota Bay, Florida. *USA Environ. Toxicol. Chem.*, **25**: 2405–2412 (2006).
208. Smithwick, M., Norstrom, R. J., Mabury, S. A., Solomon, K., Evans, T. J., Stirling, I., *et al.* Temporal trends of perfluoroalkyl contaminants in polar bears (*Ursus maritimus*) from two locations in the North American Arctic, 1972–2002. *Environ. Sci. Technol.*, **40**: 1139–1143 (2006).
209. Ellis, D. A., Martin, J. W., De Silva, A. O., Mabury, S. A., Hurley, M. D., Sulbaek Andersen, M. P., *et al.* Degradation of fluorotelomer alcohols: a likely atmospheric source of perfluorinated carboxylic acids. *Environ. Sci. Technol.*, **38**: 3316–3321 (2004).

210. Smithwick, M. M., Mabury, S. A., Solomon, K. R., Sonne, C., Martin, J. W., Born, E. W., *et al.* Circumpolar study of perfluoroalkyl contaminants in polar bears (*Ursus maritimus*). *Environ. Sci. Technol.*, **39**: 5517–5523 (2005).
211. Holmstrom, K. E., Jarnberg, U., Bignert, A. Temporal trends of PFOS and PFOA in guillemot eggs from the Baltic Sea, 1968–2003. *Environ. Sci. Technol.*, **39**: 80–84 (2005).
212. Verreault, J., Berger, U., Gabrielsen, G. W. Trend of perfluorinated alkyl substances in herring gull eggs from two coastal colonies in northern Norway: 1983–2003. *Environ. Sci. Technol.*, **41**: 6671–6677 (2007).

4

Chirality as an Environmental Forensics Tool

Charles S. Wong^{1,2} and Nicholas A. Warner^{2,3}

¹Richardson College for the Environment, University of Winnipeg, Winnipeg, Canada

²Department of Chemistry, University of Alberta, Edmonton, Canada

³Polar Environmental Centre, Norwegian Institute of Air Research, Tromsø, Norway

4.1 Introduction

This chapter is a comprehensive critical review of the use of chirality as a forensics tool to detect, probe and gain insight into biologically mediated environmental processes affecting persistent organic pollutants (POPs). About 25% of all agrochemicals are chiral [1], as are many other legacy and current-use chemicals. Among the classic legacy POPs, a number are chiral, such as 19 polychlorinated biphenyl (PCB) congeners [2]. A number of the organochlorine (OC) pesticides are also chiral: the technical dichlorodiphenyltrichloroethane (DDT) component *o,p'*-DDT and its anaerobic metabolite *o,p'*-DDD; α -hexachlorocyclohexane (α -HCH), the only chiral isomer of technical HCH; many of the cyclodienes in the chlordane class, including major components *cis*- and *trans*-chlordane and heptachlor, minor components such as MC-5, MC-6, MC-7, and U82, and degradates such as oxychlordane and heptachlor epoxide; and most of the possible chlorobornane congeners of toxaphene [3]. Many emerging POPs are also chiral, such as pyrethroid insecticides, hexabromocyclododecane (HBCDD), other brominated flame retardants such as polybrominated biphenyls (PBBs) [4] and some ethers [5], and PCB metabolites such as hydroxylated [6] and methylsulfonyl PCBs [7]. Surprisingly, the chirality of pollutants has received relatively limited attention, despite the significantly different toxicity that enantiomers may have compared to each other and to the racemate, and the insights that enantiomer analysis can bring to understanding processes affecting pollutants in the environment.

The enantiomers of a chiral compound have identical physical and chemical properties. Accordingly, abiotic processes such as air–water exchange, sorption, and abiotic transformation are generally identical for both enantiomers. However, biochemical processes may differ among stereoisomers because they can interact differentially with other chiral molecules such as enzymes and biological receptors. Thus, enantiomers may have different biological and toxicological effects.

The differential toxicity of pollutant enantiomers is one of the major reasons helping to understand stereoisomer-specific environmental fate and effects in POPs. A few of these effects have been characterized. For example, (–)-*o,p'*-DDT has the weak estrogenic activity attributed to *o,p'*-DDT as an endocrine disruptor, as (+)-*o,p'*-DDT is inactive [8–10]. The enantiomers of PCB 139 differentially induce cytochrome P-450 2B (CYP2B) isozymes in rats [11]. This congener, as well as PCBs 88 and 197, also induces CYP2B differentially in chick embryo hepatocytes [12]. Multi-*ortho*-substituted PCBs are neurotoxic. This endpoint can be enantioselective, as demonstrated by (–)-PCB 136 enhancing the binding of ryanodine to its receptor and holding calcium ion channels open as part of the mechanism for muscle contraction, and the (+)-enantiomer not inhibiting the (–)-enantiomer's activity [13]. On the other hand, racemic PCB 84 is more potent at inhibiting calcium ion uptake to rat cerebellum microsomes [14] than the individual enantiomers, which had effects that differed from one another. Differential effects of α -HCH enantiomers on growth stimulation and cytotoxicity have also been observed in rat hepatocytes [15]. Components of chlordane and heptachlor have enantiomer-specific insecticidal properties [16, 17]. The 1*S-cis*-enantiomer of the synthetic pyrethroid bifenthrin is over a hundred times more potent at inducing vitellogenin, a fish yolk protein precursor normally produced in females, in Japanese medaka (*Oryzias latipes*) compared to the 1*R-cis*-enantiomer [18]. However, 1*R-cis*-bifenthrin is the only enantiomer of this pyrethroid that exhibited acute toxicity towards the daphnid *Ceriodaphnia dubia* [19]. Large differences of up to fortyfold in lethal acute levels of *cis*-permethrin were observed towards this species, suggesting that aquatic toxicity was primarily due to a specific enantiomer in the racemic mixture [20]. In zebrafish, (–)-*trans*-permethrin had the greatest estrogenic activity in terms of hepatic messenger RNA expression of vitellogenin genes [21]. Esfenvalerate, the 2*S, 3S* stereoisomer of the synthetic pyrethroid fenvalerate, is an example of chirality being taken into account in pesticide design in that only the active ingredient with insecticidal activity is applied, thereby lowering the application rate [22].

Most studies of chiral pollutants do not account for fate and effects of individual stereoisomers. Thus, our current knowledge of chiral pollutants is often inaccurate, as the implicit assumption that enantiomers have identical environmental behavior is incorrect. Nonenantioselective chemical analyses cannot measure enantiomer compositions, but only the sum total of stereoisomers. Thus, if, for example, a more toxic enantiomer is preferentially degraded, then exposure assessments from nonenantioselective measurements would overestimate toxicity. Conversely, preferential elimination of relatively innocuous enantiomers would thus underestimate toxicity. The enantiomer-specific activities and side-effects of some chiral agrochemicals have prompted regulatory authorities in the Netherlands and Switzerland to revoke registrations for racemates of chiral phenoxy herbicides, while approving registrations of single-enantiomer products [1], which are increasing worldwide. Canada's Pest Management Regulatory Agency requires information on manufacturing processes and analytical separations of enantiomers for chiral pesticide registration [23, 24]. However, information on chirality is severely lacking and needed by regulatory bodies. The US Environmental Protection Agency has recognized the issue of chirality in pesticide

registration [25] and risk assessment [26]. However, in general, regulators have insufficient enantiomer-specific environmental fate and toxicity information [27, 28] needed for proper risk assessment. These regulatory actions and needs underscore the need to understand stereospecific effects of chiral xenobiotics in the environment.

The use of chirality to understand environmental chemical fate processes is another major reason for studying pollutant enantiomers. Because abiotic processes generally affect both enantiomers of a chiral compound identically, its enantiomer composition will not change when physical and chemical processes change concentrations and fluxes. However, biologically mediated processes may be enantioselective and change the enantiomer composition. Thus, the change in relative enantiomer proportions is a tracer of enantioselective biologically mediated activity unaffected by abiotic processes. This feature is highly useful, as environmental processes are often complex and variable. As a result, detecting and analyzing biochemical processes such as biotransformation can be confounded by the many abiotic processes also acting upon chemicals of interest without a specific biochemical tracer.

Much of the focus of this chapter is on the legacy past-use classical POPs covered under the Stockholm Convention (see Chapter 1). However, research to understand current-use emerging persistent organic pollutants is also discussed, including pesticides (e.g. pyrethroids), synthetic musks, POP metabolites (e.g. methylsulfonyl PCBs), and brominated flame retardants (e.g. HBCDD). Discussion is limited to persistent compounds with long half-lives (i.e. years to decades and beyond). While many current-use and emerging pollutants (e.g. polar pesticides, pharmaceuticals) are also chiral, they are often much less persistent in the environment and are reviewed elsewhere (e.g. see References [29, 30]). Our discussion briefly covers methods to measure and quantify enantiomer composition of POPs. We then discuss enantiomer composition of chiral POPs within various environmental media (e.g. water, sediment, soil, and biota) and how these compositions have been used to gain insight to enantioselective biochemical processes. Specific examples of using chirality as a apportionment tool to understand pollutant sources and to characterize environmental transport processes are also highlighted. Finally, caveats and limitations on using chirality as an environmental forensics tool are detailed.

4.2 Classes of Chiral Legacy and Persistent Organic Pollutants

4.2.1 Organochlorine Pesticides

The organochlorine pesticides have similar uses and histories. The insecticide DDT was originally introduced during World War II to kill malaria-bearing mosquitoes and lice causing typhus, and was widely used as an insecticide until it was banned in the US and other industrialized countries in the early 1970s [31]. It remains in restricted use for malaria control in developing countries. Technical-grade DDT contains up to 25% *o,p'*-DDT, which can be anaerobically degraded to *o,p'*-DDD. Both are chiral (Figure 4.1). Technical HCH is another heavily used and ubiquitous pesticide introduced in World War II, and consists of three major isomers: α -HCH, the most abundant (60–70%) and the only chiral isomer (Figure 4.2); β -HCH (5–12%), the most bioaccumulative isomer; γ -HCH or lindane (10–12%), the active insecticidal isomer (Figure 4.2); and minor amounts of δ - and ϵ -isomers [32]. The technical product was banned in the US and Canada during the 1970s, in Europe in the 1970s and 1980s, in China in 1983, and in the former Soviet Union in 1990. However, it continued to be used past 1990 in India and some African and South American

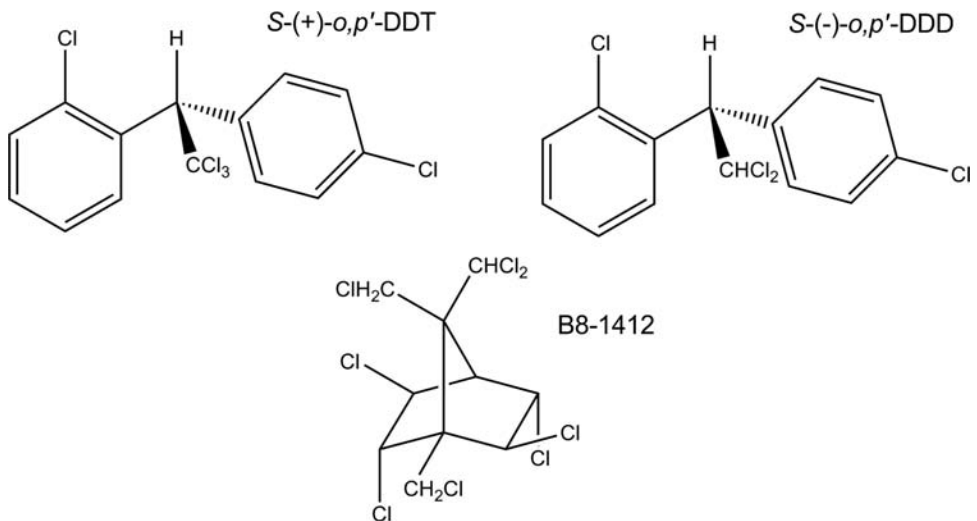

Figure 4.1 Structures of *o,p'*-DDT, *o,p'*-DDD, and toxaphene congener B8-1412 [256]. Only one enantiomer of each compound is depicted. Absolute configuration of chiral DDT components from Reference [31]

countries [33]. Lindane remains in use as a replacement for technical HCH. Technical chlordane, a complex mixture of more than 140 components [34], was widely used as an agricultural insecticide and as a termiticide from the 1950s to the 1980s, at which time active use was either phased out or severely restricted in most countries. Some of these components are chiral (Figure 4.3), including the stable degradation products oxychlordane and heptachlor-*exo*-epoxide. While the *endo*-epoxide of heptachlor can exist, only the *exo*-epoxide or 'B' isomer is found in the environment, given its greater stability [35], and is the isomer hereafter referred to as 'heptachlor epoxide'. Toxaphene, another heavily used pesticide banned in the 1980s, is an extremely complex mixture of mostly chlorinated bornanes, which number in the hundreds in the technical product. This is a small fraction of the 32 768 possible chlorobornane congeners, most of which are chiral [3] (Figure 4.1) and are referred to using the nomenclature of Andrews and Vetter [36].

4.2.2 PCBs and Their Metabolites

Polychlorinated biphenyls were first synthesized in 1929 and can exist as up to 209 individual congeners. They were manufactured as technical mixtures (e.g. Aroclor, Kanechlor, Sovol, etc.) consisting of up to about a hundred individual congeners. These mixtures were mainly used as dielectric fluids in capacitors and transformers, but had other uses (e.g. heat transfer fluids, plasticizers, carbonless paper). Production of PCBs was halted in industrialized countries in the 1970s. Seventy-eight congeners are atropisomeric, meaning they are asymmetric about their long axis and thus chiral when in their energetically favored nonplanar conformations [2]. Of that number, 19 have three or four *ortho* chlorine atoms, restricting rotation about the C–C bond between the two phenyl rings (Figure 4.4). These 19 congeners are stable under environmental conditions, with rotation energies of 45–60 kcal/mol [37, 38] or a minimum half-life for racemization of at least 200 billion years at human

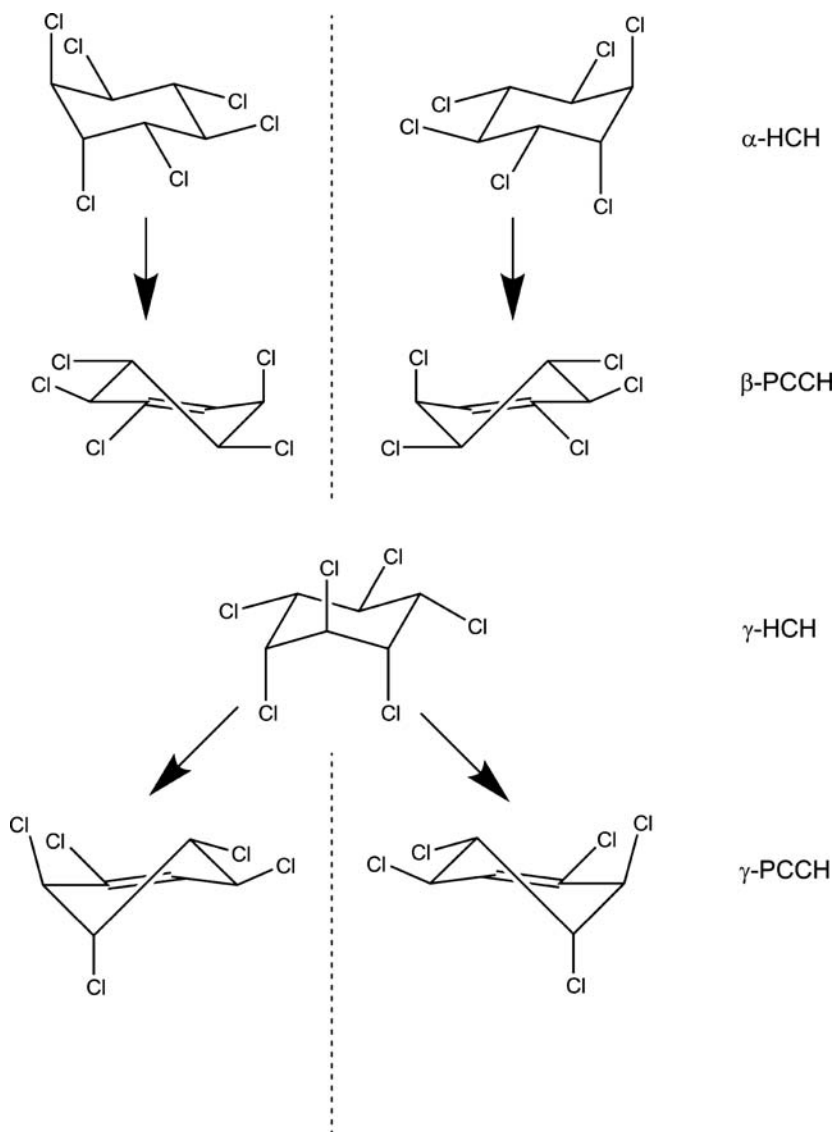

Figure 4.2 Structures of chiral α -HCH and its chiral degradate β -PCCH, and achiral (prochiral) γ -HCH and its chiral degradation γ -PCCH

body temperature! While atropisomers of di-*ortho* chlorine-substituted congeners can be stable at temperatures near the freezing point of water (e.g. in sediments of cold water bodies) [39], they racemize at room temperature, and no environmental measurements for such congeners have yet been reported. In this chapter, we will refer to individual PCB congeners with the commonly used Ballschmitter and Zell numbering nomenclature [40].

Detoxification of PCBs by Phase I conjugation produces hydroxylated PCBs (OH-PCBs) through either direct hydroxide insertion or via arene oxide intermediates [7]. The latter can

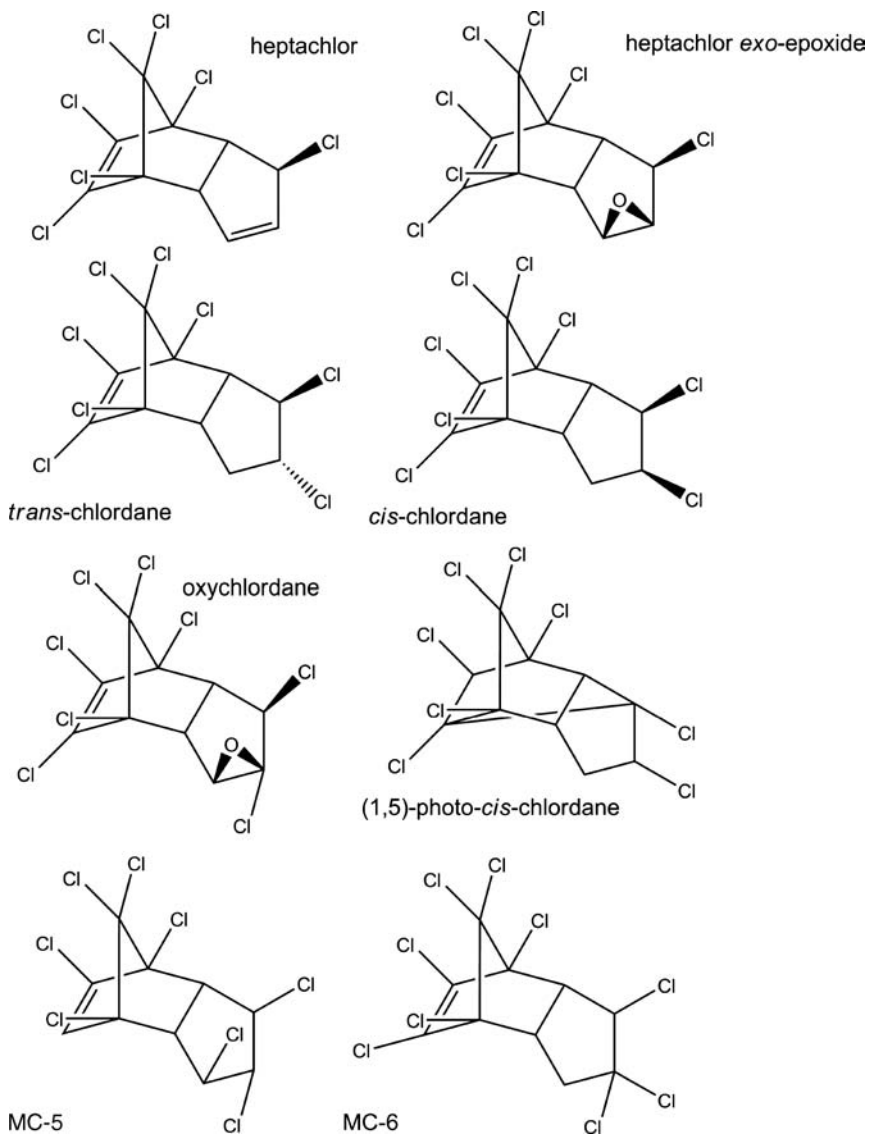

Figure 4.3 Structures of some chiral chlordane constituents. The (+)-enantiomers and absolute configurations of heptachlor, heptachlor exo-epoxide, cis-chlordane, trans-chlordane, and oxychlordane are shown [16, 17]. Only one enantiomer of each compound is depicted

further react to form glutathione conjugates, which in turn can undergo a series of reactions through the mercapturic acid pathway [41] to form methylthio-PCBs and then PCB methyl sulfones ($\text{MeSO}_2\text{-PCBs}$). As with the parent compounds, PCB metabolites can also be atropisomeric [6, 7, 42], such as the OH-PCBs [6] and the $\text{MeSO}_2\text{-PCB}$ end products (Figure 4.4). Of the 837 possible $\text{MeSO}_2\text{-PCBs}$, 456 are chiral, with 170 environmentally stable due to tri- or tetra-*ortho* substitution [42]. In practice, only about 60 $\text{MeSO}_2\text{-PCB}$ congeners have been found in the environment [7]. Of those, only 10 are chiral. In this

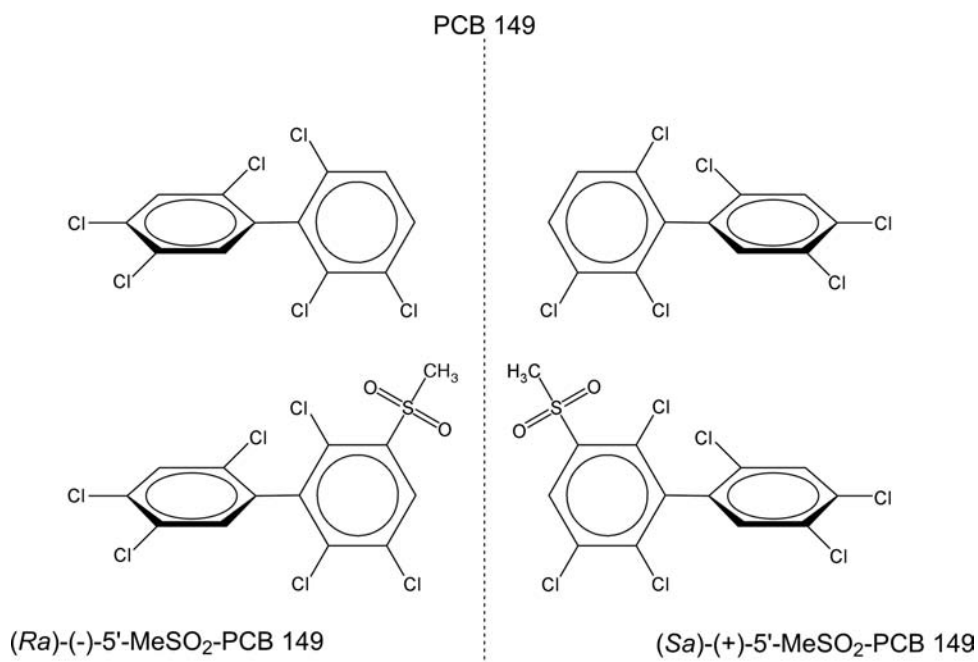

Figure 4.4 Structures of atropisomeric 2,2',3,4',5',6-hexachlorobiphenyl (PCB 149) and 5-methylsulfonyl-2,2',3,4',5',6-hexachlorobiphenyl (5-MeSO₂-PCB 149). Absolute structure and optical rotation of 5-MeSO₂-PCB 149 are from Reference [95]; those of PCB 149 are unknown to date

discussion, nomenclature and abbreviations for PCB metabolites follow the recommendations of Maervoet *et al.* [43].

4.2.3 Pyrethroids

Pyrethroids (Figure 4.5) are a currently used class of agricultural and urban insecticides, and are expected to become more important given increasing restrictions on current-use organophosphate pesticides. Unlike organophosphates, pyrethroids have low toxicity to mammals, making their use attractive. However, they are acutely toxic to aquatic organisms [44]. Unlike many current-use pesticides, pyrethroids are nonpolar and sorb strongly to particles, which are subject to runoff. Thus, pyrethroids are likely to end up in sediments post-application, where they can be bioavailable to the aquatic food web [45]. All pyrethroids are chiral, commonly with more than one asymmetric center resulting in several sets of diastereomers. Enantiomers of pyrethroids commonly have differential biological activity; e.g. only two of the eight cypermethrin stereoisomers have insecticidal activity [46].

4.2.4 Polycyclic Musks

More than 6 000 tonnes of polycyclic musks (Figure 4.6) have been produced worldwide since 1996 [47]. They are present at concentrations of up to several mg/g of product [48] as fragrances in perfumes, detergents, soaps, lotions, air fresheners, and other scented personal products. These compounds are hydrophobic and persistent, bioaccumulate in food webs, have toxic effects, and are widespread in surface waters, sediments, fish, and human adipose tissues and

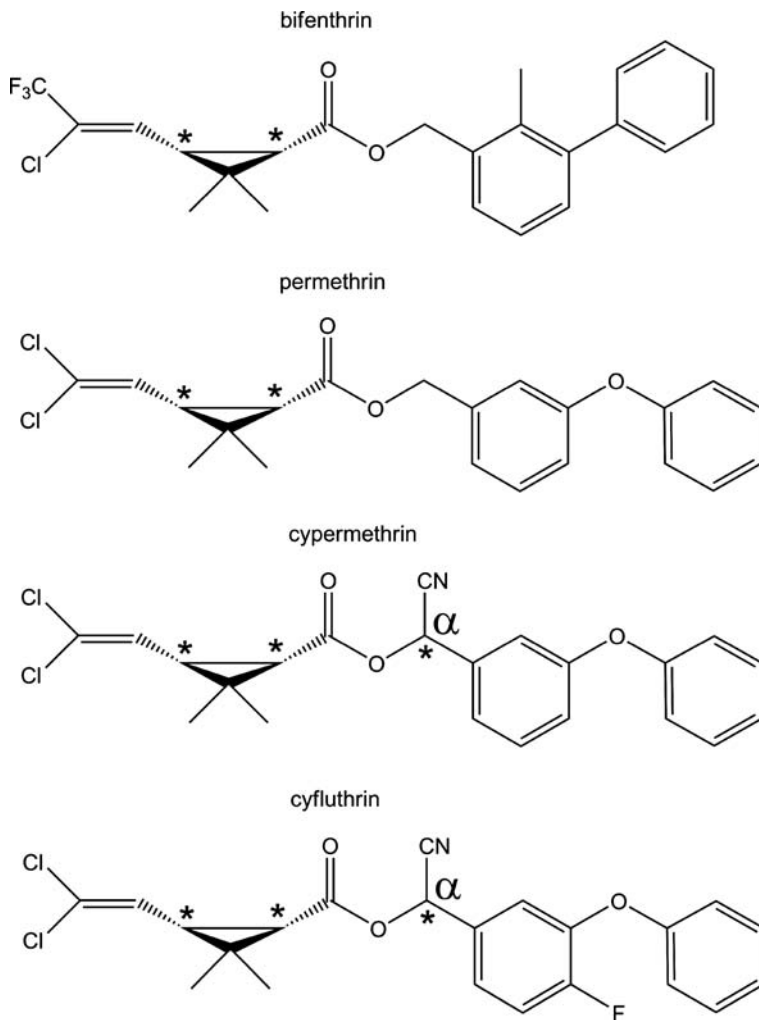

Figure 4.5 Structures of some synthetic pyrethroid pesticides. Chiral centers are denoted by asterisks, α carbon by α . Only one enantiomer of each compound is depicted

milk [47]. Thus, they are considered emerging pollutants of increasing concern, particularly as environmental burdens are increasing based on measured concentration profiles in sediment cores from Lakes Erie and Ontario [49]. Several of the polycyclic musks are chiral (Figure 4.6), such as AHDI (Phantolide), AHTN (Tonalide), HHCB (Galaxolide), and ATII (Traseolide). The latter two compounds exist as a pair of diastereomers, given two asymmetric centers in those compounds; however, more than 95% of technical ATII consists of the *trans* isomer.

4.2.5 Brominated Flame Retardants (See Also Chapter 2)

Hexabromocyclododecane (HBCDD) is a flame retardant in polystyrene foams used in upholstered furniture and building insulation, with an estimated production of 16 700 tonnes

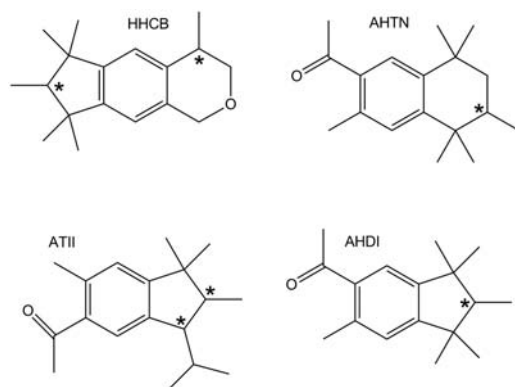

Figure 4.6 Structures of polycyclic musks HHCB (1,3,4,6,7,8-hexahydro-4,6,6,7,8,8-hexamethylcyclopenta-(g)-2-benzopyran), AHTN (7-acetyl-1,1,3,4,4,6-hexamethyltetralin), ATII (5-acetyl-1,1,2,6-tetramethyl-3-isopropylindene), and AHDI (6-acetyl-1,1,2,3,3,5-hexamethyldihydroindene). Asterisks denote stereogenic centers

in 2001 [50, 51]. Sixteen possible HBCDD stereoisomers are possible [51]. However, technical products are a mixture of three sets of diastereomers: α - (10–13%), β - (0.5–12%) and the dominant γ -isomer (75–89%) [52] (Figure 4.7) with minor amounts of the meso δ - and ϵ -isomers [53]. Thermal incorporation of technical HBCDD to insulating materials results in isomerization [52, 54, 55], leading to a predominance of α -HBCDD (ca. 78%) in such materials. The absolute configurations of HBCDD isomers was recently determined [56, 57]. Hexabromocyclododecane is an emerging POP of concern, as it is ubiquitous worldwide [58, 59], bioaccumulates [60, 61], and can have chronic neurotoxic and endocrine disrupting effects despite a low acute toxicity [62]. Most studies have focused on the three major sets of diastereomers, which have sufficiently different physical and chemical properties to bioaccumulate and biotransform differentially [59, 60]. Biota preferentially bioaccumulate α -HBCDD [60, 63], possibly by differences in isomer hydrophobicity [64], *in vivo* biotransformation [59], and/or possible *in vivo* isomerization [63].

Other brominated compounds of environmental concern are also chiral. Polybrominated biphenyls, like PCBs, were used as capacitor fluids in mixtures of congeners (e.g. Firemaster), and are also atropisomeric [4]. While HBCDD is the most common chiral brominated flame retardant, others exist, such as 2,3-dibromopropyl-2,4,6-tribromophenyl ether (Figure 4.7). As of this writing, little is known about environmental occurrence, fate, and effects of these other chiral flame retardants, and with one exception [5] nothing has yet been published on their enantiomers.

4.3 Measuring and Quantifying Enantiomer composition of POPs

4.3.1 Measurement of Chiral POPs

Despite the long recognition of chirality in POPs, it has only been fairly recently that studies of chiral POPs have been possible, after the introduction of analytical technology for stereoisomer separation by enantioselective gas chromatography (GC), high performance liquid

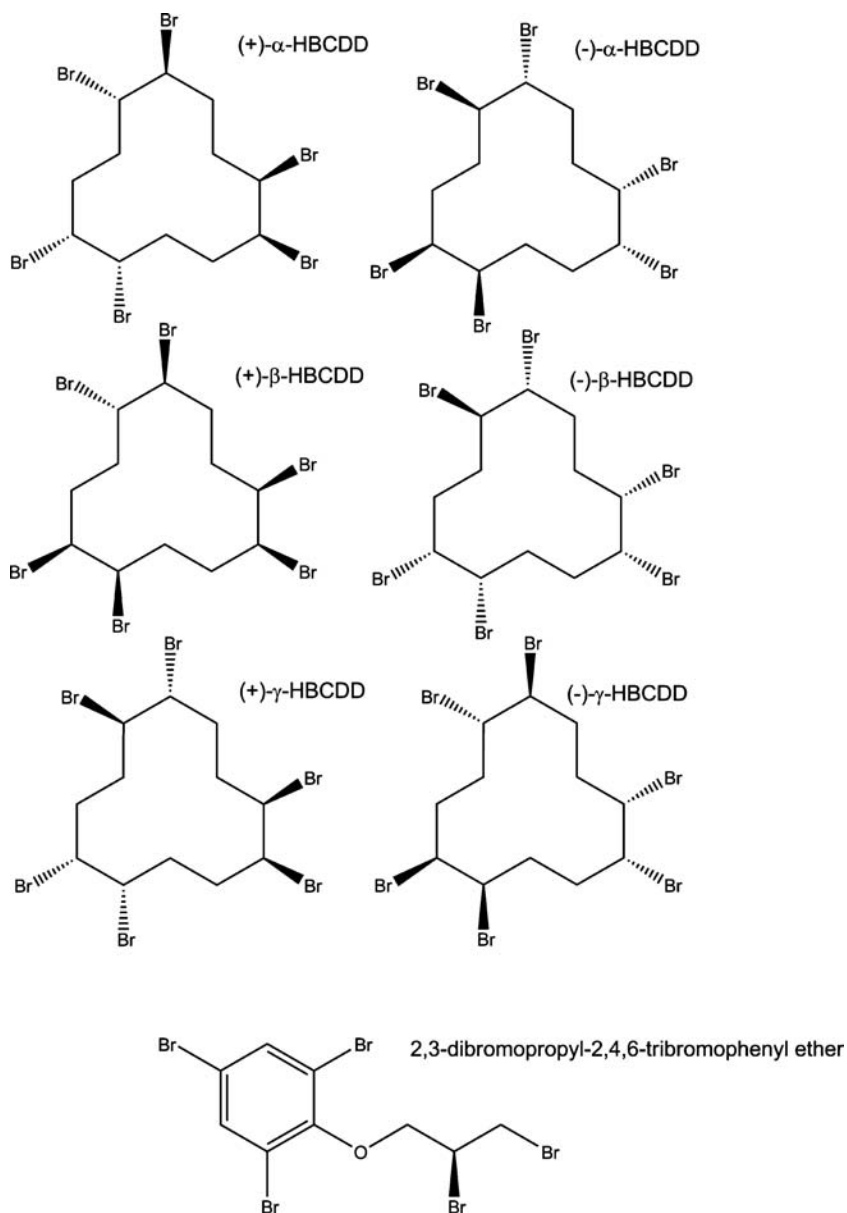

Figure 4.7 Structures of chiral brominated flame retardants α -, β -, and γ -hexabromocyclododecanes [56, 57] and 2,3-dibromopropyl-2,4,6-tribromophenyl ether (only one enantiomer shown)

chromatography (HPLC), and capillary electrophoresis (CE). For example, although PCB atropisomers were first predicted to exist in 1974 [2], the first HPLC-based separations were reported in 1985, over a decade later [65], and the first environmental measurements in 1995, yet another decade after that [66]. Indeed, most of the initial research on chiral POPs focused on developing enantioselective analytical techniques, particularly by GC [67], as it is the most

suitable chromatographic tool for separations of nonpolar semi-volatile analytes. Multidimensional GC with heart-cutting of selected peaks from an achiral column to an enantioselective second column, although less common, is useful in eliminating interferences, particularly for complex classes of POPs such as PCBs [68–76] and toxaphene [77, 78]. More recently, comprehensive two-dimensional GC \times GC, in which effluent from the first dimension column is focused and pulsed continually to a short second dimension column [79], has been used for enantioselective separations [73, 74, 80–82]. Enantioselective HPLC has been less popular for enantiomer resolution of chiral POPs, given its lower chromatographic resolution compared to GC, but has been used for quantification purposes [83, 84]. More commonly, HPLC has been used to purify POP enantiomers to simplify subsequent analysis by GC [85–87]; to collect sufficient material [88] to determine chemical properties such as (+) or (–) rotational designation and chromatographic elution order [20, 39, 57, 89–93], absolute configuration by vibrational circular dichroism [94, 95], and chemical stability [96]; to characterize enantiomer-specific environmental fate and toxicity studies [19, 20, 97]; and to analyze POPs that are not thermally stable and cannot be measured by GC, such as HBCDDs [58, 98, 99]. Enantioselective CE, while a highly efficient analytical separations technique with up to a million theoretical plates, has not been used much for environmental analysis to date. Most CE applications use UV detection, which results in poor sensitivity due to the short path length of the narrow capillary [100]. Detection after chromatographic separation is commonly by means of mass spectrometry (MS) or tandem mass spectrometry (MS/MS), which have the sensitivity and selectivity for trace quantification of complex mixtures in most environmental analysis. A detailed critique of enantioselective GC, HPLC, and CE techniques and the use of MS and MS/MS for chiral POPs is beyond the scope of this work. However, these have been reviewed extensively elsewhere [15, 29, 67, 100–104].

Of additional benefit to enantioselective POP separations is the quantification of enantiomer compositions in standardized reference materials, available from sources such as the US National Institute of Standards and Technology (NIST) and Environment Canada [105, 106]. Such materials are intended for quality assurance/quality control in sample processing and instrumental analysis of their respective matrices, and enantiomer quantification extends this use to enantioselective studies.

4.3.2 Metrics for Expressing Enantiomer Composition of POPs

Two principal metrics are used for reporting enantiomer compositions of chiral POPs: the enantiomer ratio (ER) and the enantiomer fraction (EF). Most earlier studies used ER, the ratio of the (+)-enantiomer concentration over that of the (–)-enantiomer. Chromatographic parameters for calculating concentrations, such as peak area or height, can also be used. If the elution order is unknown, then the ER is reported as the ratio of the first-eluted enantiomer (E1) to the second-eluted one (E2) on a specific column and conditions:

$$\text{ER} = (+)/(-) \quad (4.1)$$

or

$$\text{ER} = (\text{E1})/(\text{E2}) \quad (4.2)$$

The ER ranges from zero to infinity, with a racemate having an ER of 1. The EF [107, 108], defined as the ratio of the (+)-enantiomer or E1-enantiomer concentration to the

sum total enantiomer concentration, is now more commonly used to describe enantiomer compositions in the environmental literature:

$$EF = \frac{(+)}{(+)+(-)} \quad (4.3)$$

or

$$EF = \frac{(E1)}{(E1)+(E2)} \quad (4.4)$$

The range in EF is from zero to unity, with a racemic value of 0.5. Enantiomer fractions are preferred to ERs, as the EF range is bounded, and a deviation from the racemic value in one direction is the same as that in the other. For example, if the (–)-enantiomer is twice the concentration as its antipode, the EF is 0.333, which is the same deviation (0.167) from a racemic EF of 0.5 as the opposite case of the (+)-enantiomer at twice the concentration as the (–)-enantiomer (EF = 0.667). The respective ERs would be 0.5 and 2. The corresponding deviations of 0.5 and 1, respectively, are *not* the same deviation from the racemic ER of 1. Thus, ERs can produce skewed data inappropriate for statistical summaries such as sample mean and standard error [109]. As a result, EFs are more amenable compared to ERs for graphical representations of data, mathematical expressions, mass balance determination, and environmental modelling [107, 109]. Individual ER and EF measurements can be converted [107, 108]:

$$EF = \frac{ER}{1+ER} = \frac{1}{1+\frac{1}{ER}} \quad (4.5)$$

Conversion of summarized values (e.g. mean ER $\pm \sigma$ to the equivalent EF $\pm \sigma$) can lead to substantial discrepancies, and should be avoided [109]. In addition, the conventions used in describing ERs and EFs may differ between studies and analytical methods. For example, enantioselective separations on different stationary phases may result in reversal of elution order and lead to different values if elution orders are not known. In this discussion, EFs are used to the extent possible, and both EF and ER are defined using Equations (4.1) and (4.3), respectively, for those analytes for which the elution order is known unless otherwise indicated. Otherwise, these metrics are defined using Equations (4.2) and (4.4) on the specified column.

4.4 Chirality to Characterize Environmental Biochemical Processes

Chirality has been used extensively to detect, quantify, and characterize environmental biochemical processes. This use takes advantage of the fact that abiotic processes generally affect both enantiomers of a chiral compound in the same way. These include processes both physical (e.g. advection and convection, phase transfer such as air–water exchange) and chemical (e.g. hydrolysis, redox reactions). In the open environment, these processes can be quite variable in nature and difficult to characterize. However, interactions with other chiral biomolecules, such as enzymes in living systems, can affect enantiomers differentially and thus change the enantiomer composition. Therefore, chirality can be used to find and gain insight into enantioselective biochemical weathering of POPs that could be difficult if not impossible to detect otherwise, particularly in species suspected of having limited metabolic activity towards POP degradation.

4.4.1 Enantiomer-Specific Microbial Biotransformation of Chiral POPs

4.4.1.1 Natural Waters

Of the chiral POPs, α -HCH is arguably the most studied. The first report of enantiomer-specific POP distributions in the environment [110] found a slight but significant enrichment of (–)- α -HCH (mean EF = 0.47) in waters of the North Sea, and suggested that the cause was microbial degradation in the water column. Similar EFs for α -HCH were subsequently observed there [111]. Racemic α -HCH was found in rain and air in nearby Norway [112], suggesting that wet deposition was not the source of enantioenriched α -HCH to the North Sea. Enantioselective microbial degradation of α -HCH was demonstrated in laboratory experiments of North Sea aerobic sediments incubated with overlying seawater [113, 114]. While chiral γ -pentachlorocyclohexane (γ -PCCH, Figure 4.2) was formed nonenantioselectively by dehydrodechlorination of achiral (i.e. prochiral) γ -HCH, α -HCH degraded to form (+)- β -PCCH (Figure 4.2) preferentially (EF = 0.54 after 28 days) [113]. However, α -HCH remained racemic in the incubation, presumably because only small amounts (ca. 10%) were degraded [113]. In turn, the degradation product (+)- β -PCCH was also preferentially removed (EF = 0.33 after 21 days). Likewise, γ -PCCH was degraded enantioselectively (EF = 0.53–0.58 after 21 days) to chlorophenols and chlorobenzene products, despite being formed nonstereoselectively from γ -HCH [114]. Microbially mediated isomerization of γ -HCH to α -HCH was not enantioselective [114]. These laboratory results were consistent with field measurements of enriched β -PCCH (EF = 0.53) in the North Sea [114]. Although the microbial consortia was not identified in these studies [113, 114], (+)- γ -PCCH was identified as 1,3*R*,4*S*,5*S*,6*R*- γ -PCCH by circular dichroism, and formed 1,2,4-trichlorophenol when enzymatically degraded by γ -hexachlorocyclohexane dehydrodechlorinase LinA in the soil bacterium *Sphingomonas paucimobilis* [115]. The antipode 1,3*S*,4*R*,5*R*,6*S*- γ -PCCH formed 1,2,3-trichlorophenol instead [115]. Nonbiological degradation processes, such as photolysis, affected both enantiomers equally as expected and were experimentally shown not to be stereoselective for α -HCH [114] and chlordanes [116].

There has been extensive analysis of α -HCH enantiomer composition in the Arctic Ocean. In 1994, enrichment of (+)- α -HCH was observed in surface waters of the Bering and Chukchi Seas, while (–)- α -HCH was enriched in the Canada Basin and the Greenland Sea [117–121]. However, by 2003 the Bering and Chukchi Seas were also enriched in (–)- α -HCH, as was the north Pacific Ocean [122] (Figure 4.8). The reversal of enantiomer preference observed in the early 1990s could be due to changes in microbial degradation in the water column, with subsequent changes over time leading to consistent enrichment of the (–)-enantiomer. The observed EFs could not be due to air–water exchange, as fugacity measurements suggested net volatilization of α -HCH [122]. Concentrations of α -HCH were lower in the Bering Sea than in the Canada Basin [118]. Concentrations of α -HCH and ratios of α -HCH/ γ -HCH decreased from the western part of the Canada Basin to the eastern part [123], with concentrations and EFs of α -HCH in the eastern Canadian Archipelago explained by mixing among the various inputs to that part of the Arctic Ocean [123].

The nonracemic compositions in the Arctic Ocean are due to microbial degradation of α -HCH both in tributary waters and within the oceanic water column. About 7% of α -HCH was enantioselectively degraded, with preferential elimination of the (+)-enantiomer, in streams draining into Amituk Lake on Cornwallis Island in the Canadian Archipelago [124]. In the lake itself, (–)- α -HCH was enriched (mean ER = 0.77) at 15–21 m depth [125].

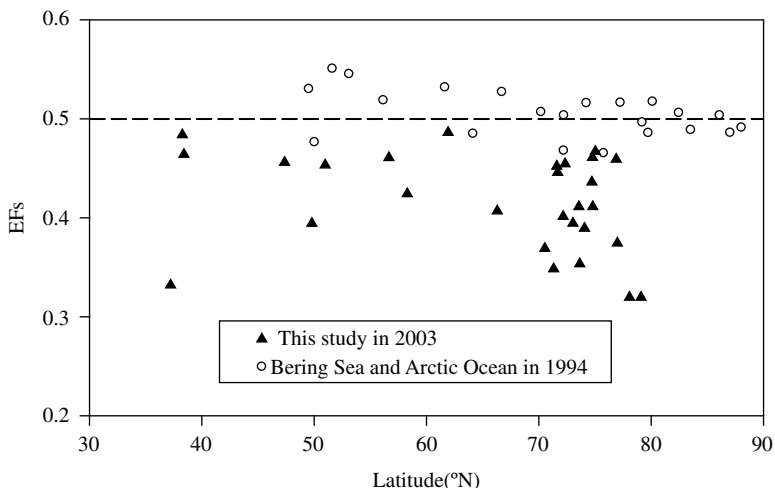

Figure 4.8 Enantiomer fractions (EFs) of α -HCH in the North Pacific Ocean, Bering Sea, and the Arctic Ocean in 1994 [118] (open squares) and in 2003 [122] (triangles). (Reproduced with permission from Environmental Science and Technology Atmospheric Hexachlorocyclohexanes in the North Pacific Ocean and the Adjacent Arctic Region: Spatial Patterns, Chiral Signatures and Sea–Air Exchanges, by Xiang Ding, Xin-Ming Wang et al., **41**(15), 5204–5209. Copyright (2007) American Chemical Society)

However, nonenantioselective microbial degradation appeared to be significant in Amituk Lake, with rate constants ranging from 0.48 to 1.13 per year [124]. Enantiomer compositions in the lake were controlled by meltwater inputs, in which most enantioselective degradation was taking place [124, 125]. Enantioselective degradation of α -HCH was related to contact time between the water column and sediments, suggesting that in nutrient-poor waters, oligotrophic bacteria in biofilms may be responsible for enantiomer-specific biotransformation of α -HCH [126]. The lake and stream waters eventually drain into the Arctic Ocean and contribute to the enrichment of (–)- α -HCH that was observed. Greater enrichment of (–)- α -HCH was observed with increasing depth in the Arctic Ocean water column [127] (Figure 4.9). *In situ* microbial rate constants based on enantiomer and concentration profiles, surface water data, and known water age at depth were 3–10 times greater than those for hydrolysis of α -HCH, and resulted in half-lives of 6 years for (+)- α -HCH and 23 years for (–)- α -HCH in the eastern Arctic [127]. These results indicate that even in cold climates, measurable biotransformation of POPs can still occur. However, the microbial populations responsible for the nonracemic compositions have yet to be identified.

Although not as well studied, nonracemic compositions of other legacy OC pesticides, as well as of α -HCH in other waters, have been observed. The Arctic Ocean was depleted in (–)-heptachlor epoxide in all regions surveyed, while *cis*- and *trans*-chlordane were nearly racemic [121]. Lake Ontario was also enriched in (–)- α -HCH (mean ER of 0.85), with enantiomer compositions that did not vary with depth but did vary in the presence of racemic sources such as precipitation and water from the tributary Niagara River [128]. The York River in Chesapeake Bay had microbial consortia that degraded (+)- α -HCH upstream [129, 130]. However, greater microbial activity was observed in more brackish waters

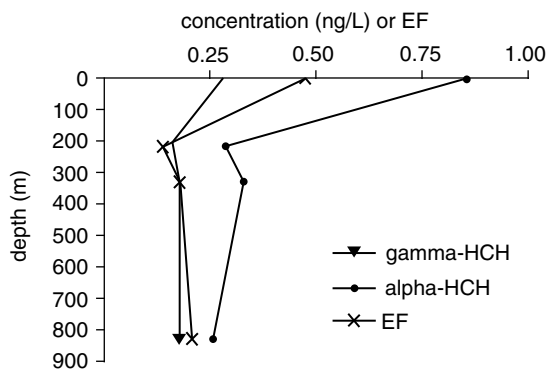

Figure 4.9 Depth profiles for concentrations of α -HCH and γ -HCH (ng/L) and α -HCH enantiomer fractions (EFs) in the eastern Arctic Ocean ($86^{\circ} 25' N$, $143^{\circ} 32' E$, sampled 5 August 1996). (Reproduced with permission from *Environmental Science and Technology, Removal of α - and γ -Hexachlorocyclohexane and Enantiomers of α -Hexachlorocyclohexane in the Eastern Arctic Ocean*, by Tom Harner, Henrik Kylin, Terry F. Bidleman and William M. J. Strachan, **33**(8), 1157–1164. Copyright (1999) American Chemical Society)

downstream, in which α -HCH was racemic, suggesting that two microbial populations existed that differed in both α -HCH degradation activity and enantioselectivity [129, 130]. In the African side of the South Atlantic Ocean, ($-$)- α -HCH was more enriched with more southerly latitudes [131] (Figure 4.10).

4.4.1.2 Wastewater and Activated Sludge

Little work has been done on POP enantiomers in wastewater and activated sludge, in part because other sources to the environment exist compared to some emerging pollutants such as drugs [29]. One of the few studies to investigate behavior of chiral legacy POPs in

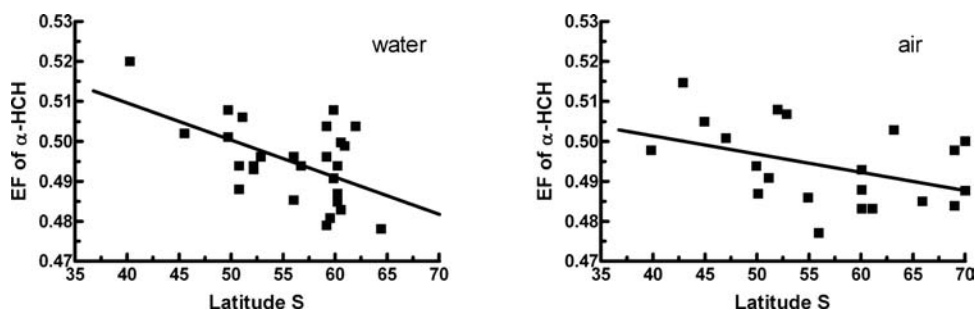

Figure 4.10 Enantiomer fractions (EFs) of α -HCH in water and air of the southern Atlantic Ocean as a function of latitude. (Reproduced with permission from *Deep-Sea Research Part II: Topical Studies in Oceanography, Air-water gas exchange of α -hexachlorohexane enantiomers in the South Atlantic Ocean and Antarctica*, by Liisa M. Jantunen, Henrik Kylin and Terry F. Bidleman, **51**(22–24), 2661–2672. Copyright (2004) Elsevier)

wastewater found that anaerobic degradation of α -HCH in activated sludge was predominantly biotic (80–85%), and favored elimination of the (+)-enantiomer [132], as was the case for the aerobic degradation previously discussed. However, discharge of treated wastewater effluent and application of wastewater-derived biosolids as agricultural fertilizers are a likely source of synthetic musks to the environment, given their use in consumer products. Polycyclic musks are hydrophobic, and thus about half their load in wastewater treatment plants is removed from the effluent [133], mostly by sorption to activated sludge that can be converted to biosolids through anaerobic digestion. The remainder of musk loss is likely through volatilization [134], with little biotransformation predicted by achiral analysis. These observations of polycyclic musk recalcitrance to degradation are consistent with the few observations of musk enantiomers to date, which have found mostly racemic compositions in raw wastewater, suggesting that little stereoselective degradation occurred prior to environmental release [135]. However, wastewater effluent had nonracemic ATII [135]. Sludge that was stabilized aerobically or anaerobically had racemic *cis*- and *trans*-HHCB, but had significantly nonracemic residues of ATII and AHTN, indicating that some stereoselective removal of these compounds is possible in wastewater treatment [135].

While brominated flame retardants, including HBCDD, were reductively dehalogenated in laboratory anaerobic microcosms of sewage sludge, such degradation was not enantioselective for the three major HBCDD isomers in that study [136].

4.4.1.3 *Sediment*

As noted, POPs sorb strongly to natural organic carbon in soil and sediment particles. Thus, soils and sediments are a major environmental sink for POPs that may subsequently be biotransformed microbially via enantioselective aerobic and anaerobic reactions. Understanding this enantioselectivity may provide enhanced insights into the enzymes and populations involved, and allows prediction of degradation rates of POPs sequestered in a long-term reservoir.

α -HCH

While α -HCH is one of the most frequently studied chiral legacy pesticides in air and water, only limited measurements have been made of its enantiomers in soils and sediments, given its relatively low propensity to sorb to natural organic matter compared to other POPs ($\log K_{ow}$ of 3.9 [32]). A depletion of (+)- α -HCH (EF = 0.39) was observed in surficial sediments of the Northwater Polynya [137]. This value was more nonracemic than the water column composition (EF = 0.45) [137], suggesting either preferential microbial degradation of (+)- α -HCH as it descended in the water column [127] and/or further degradation once deposited in sediments.

Chlordanes

The enantiomer composition of chlordanes in sediments appears to reflect its source over time. An annually laminated lake sediment core, undisturbed by bioturbation, from Devon Island in the Canadian Arctic had racemic *trans*-chlordane at depths deposited before 1950, with EFs from 0.49 to 0.50 (Figure 4.11). However, EFs were increasingly nonracemic in more recently deposited material, ranging from an EF of 0.48 in 1957 to 0.46 in 1999 when the core was sampled [138, 139]. This observation suggests that environmental burdens of chlordane prior to the mid-1950s were racemic, while subsequent emissions were due increasingly to weathered nonracemic material microbially degraded in soils before being volatilized and redeposited in the core [138, 139]. This hypothesis is supported by measurements of preferential depletion of

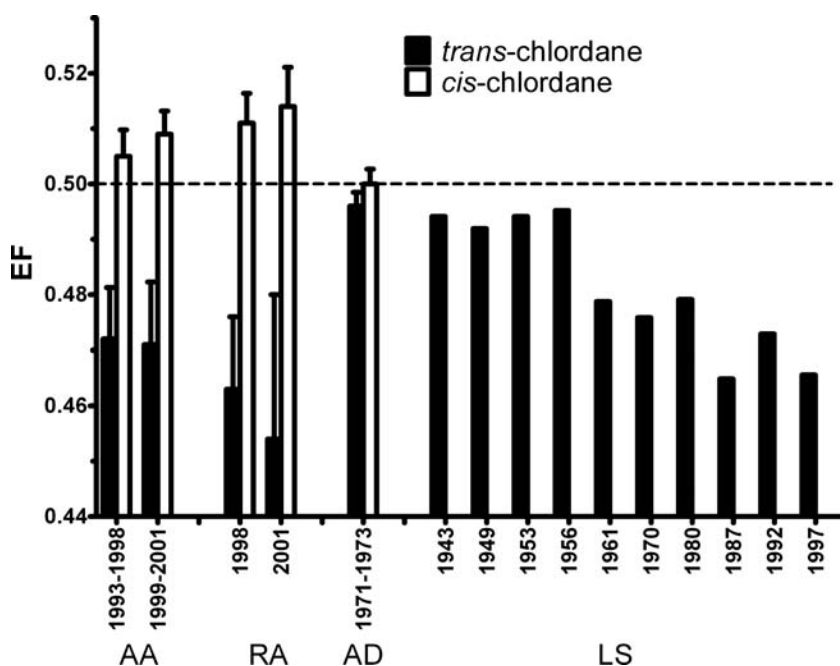

Figure 4.11 Enantiomer fractions of *cis*-chlordane and *trans*-chlordane in air samples from the Arctic (AA), southern Sweden (RA), historical atmospheric deposition samples from 1971–1973 (AD), and in sediment cores of Lake DV-09, Devon Island, Canada). Error bars are σ . (Reproduced with permission from Atmospheric Environment, *Chiral signatures of chlordanes indicate changing sources to the atmosphere over the past 30 years*, by Terry F. Bidleman, Fiona Wong et al., **38**(35), 5963–5970. Copyright (2004) Elsevier)

(+)-*trans*-chlordane in 70% of soils throughout the world [140], with EFs ranging from 0.40 to 0.48 [138, 140]. In contrast, racemic *cis*- and *trans*-chlordane were observed in sediment cores of Long Island Sound [141]. Unlike surface soils, which are typically aerobic and frequently have weathered chlordane residues from soil microbial action [140, 142–147], the lack of enantioselectivity in the Long Island Sound sediments suggests but does not prove that anaerobic microbial degradation did not occur there. The racemic residues also suggest that the source of the chlordane was soils from house foundations [141]. Racemic *cis*- and *trans*-chlordane in sediments of urban Toronto lakes and ponds, in conjunction with high *trans*-chlordane/*cis*-chlordane ratios representing a greater proportion of the more recalcitrant *trans*-isomer in total chlordanes, support the hypothesis that fresher inputs of chlordane from sources such as house foundations may be responsible for sediment residues found near urban areas [148].

Toxaphene

As with chlordanes, toxaphene can be nonracemic in sediments, but predominantly from *in situ* microbial degradation. Several chlorobornane enantiomers were quantified in a 1992 sediment core from Hanson Lake, Yukon, Canada, treated with toxaphene as a piscicide in 1963 [149]. Two hexachlorinated congeners, B6-923 and an unidentified congener, were

racemic throughout the core. However, another dominant heptachlorinated congener, B7-1001, had nonracemic EFs ranging from 0.44 (Equation (4.4) on Chirasil-Dex) in the deepest sediments deposited around 1950 to 0.41 in the most recent 1992 surficial sediments. While both B6-923 and B7-1001 are congeners likely formed by reductive dechlorination of more chlorinated bornane congeners [149], the lack of higher chlorinated congeners and the reduced number of technical toxaphene congeners in the core suggested enantioselective degradation of B7-1001 after it was formed. Only one enantiomer of B6-923 was produced by laboratory reductive dechlorination of a heptachlorobornane in an anaerobic soil [150], suggesting that microbial consortia responsible in Hanson Lake were not those present in the laboratory study. In contrast, nine chlorobornane congeners, including B6-923 and B7-1001, were essentially racemic in estuary sediments heavily contaminated with toxaphene in coastal Georgia, USA [151]. The presence of likely parent congeners of B6-923 at this site suggested that reductive dechlorination, if it had taken place at all, was not dominant, possibly due to high toxaphene concentrations and/or lack of activity of appropriate microbial communities.

DDT compounds

Few EF measurements exist for chiral DDT compounds to date in sediments. African soils were mostly racemic, with one sample that had a preferential accumulation of (+)-*o,p'*-DDT (EF = 0.541) [152]. In Toronto-area lake and pond sediments, *o,p'*-DDT was nonracemic at some sites, with either the (+) or (–)-enantiomer preferentially present [148]. Urban sediments tended to have nearly racemic *o,p'*-DDT [148], consistent with high DDT/total DDT ratios suggesting fresh pesticide inputs that had not yet had time to degrade.

PCBs

Site-specific PCB enantiomer compositions have been observed in field studies of sediments. Microbial degradation of PCBs by both aerobic and anaerobic pathways was commonly thought to require high concentrations (e.g. at least 30–80 µg/g) [153, 154], and in the case of anaerobic reductive dechlorination, to take months to years for significant degradation to occur [155]. Thus, degradation of most PCBs in sediments was thought to be not likely. This hypothesis is supported by several studies on PCB chirality. The first measurements of chiral PCBs in sediments found racemic residues of PCBs 95, 132, and 149 in sediments of the river Elsenz in southern Germany [71]. Similar results were found for PCBs 91, 95, 136, 149, 174, 176, and 183 in Environment Canada Certified Reference Material EC-5, consisting of sediments from the mouth of the Humber River in Toronto [105]. Thus, no evidence for stereoselective PCB microbial degradation was observed at these sites. This is likely to be true in the rest of Lake Ontario, based on racemic distributions of PCBs in a depositional sediment core [156], strong similarities in organic carbon content and physical and chemical properties of Lake Ontario deep sediments [157], and rapid circulation of sediments throughout the lake [158, 159].

In contrast, NIST Standard Reference Material SRM 1939 from Hudson River sediment in New York state had an EF of 0.7 for PCB 95 (Equation (4.4) on Chirasil-Dex) [70]. Similar nonracemic residues were reported for PCBs 95, 136, 149, 174, and 183 in this SRM [106]. These sediments are heavily contaminated with PCBs from historical releases from the General Electric capacitor plant in Schenectady, New York. Microbially mediated biotransformation of PCBs has occurred in these sediments by both anaerobic reductive dechlorination [155] and aerobic oxygenase and dioxygenase activity [153]. A subsequent,

more extensive survey found nonracemic amounts of PCBs 91, 95, 132, 136, 149, 174, 176, and 183 in river sediments throughout the US [160], while a recent survey of sediments from Toronto-area lakes and ponds found PCB 95 EFs as low as 0.409 [148]. Patterns in EFs among congeners were consistent with known reductive dechlorination patterns by microbial consortia [155] in the Hudson River. Moreover, the enantiomer preference of PCB 91 was reversed between the Hudson River ($EF > 0.5$ using Equation (4.4) on Chirasil-Dex) and Housatonic River, Connecticut, sediments ($EF < 0.5$) [160]. This observation was consistent with the idea that these sediments had different microbial consortia with known different reductive dechlorination patterns [155] with distinct enantiomer preferences [160]. Reversals in PCB enantioselectivity have also been observed at different depths within sediment cores of Lake Hartwell, a contaminated artificial reservoir in South Carolina [156]. These reversals suggest that microbial consortia that can biotransform PCBs by different pathways may be active at the same site, although not necessarily at the same time.

Reductive dechlorination was long suspected at Lake Hartwell based on accumulation of *ortho*-only congeners, the end product of *meta*- and *para*-dechlorination [161]. However, this was not conclusively shown until enantiomer analysis found nonracemic PCBs in sediments at depth, which could only result from reductive dechlorination [160]. Lake Hartwell sediments had highly nonracemic PCB residues that correlated to some extent with total PCB concentration, suggesting that higher PCB concentrations provided more substrate for dechlorinating consortia [156]. However, total PCB concentrations in the cores studied were generally below the 30–80 $\mu\text{g/g}$ minimum suggested as necessary for reductive dechlorination, indicating that if a threshold concentration exists, it is lower than this value. Laboratory experiments occur on a timescale of months to several years, and may be too short to capture long-term reductive dechlorination activity *in situ* without a tracer specific to biotransformation such as chirality. This hypothesis is consistent with estimated dechlorination half-lives in Lake Hartwell sediments of 10–30 years [156], longer than the timescale of laboratory experiments. While degradation may seem slow, the estimated half-lives were on the same magnitude as that estimated for burial of contaminated material by clean sediments [162]. This assessment suggests that microbially mediated biotransformation may also have a role in reducing the bioavailability of PCBs to the overlying waters.

Anaerobic reductive dechlorination of chiral PCBs confirmed that microbial reductive dechlorination *in situ* was possible in Lake Hartwell [163]. Microcosms with sediments from the same cores [156] spiked with racemic PCB 132 reductively *meta*-dechlorinated this congener nonenantioselectively to PCB 91, which in turn was stereoselectively *meta*-dechlorinated to achiral PCB 51 (Figure 4.12). Similarly, PCB 149 was nonstereoselectively *para*-dechlorinated to PCB 95, in turn enantioselectively *meta*-dechlorinated to achiral PCB 53 [163]. The enantiomer preferences for PCB 149 dechlorination were consistent between the laboratory microcosms [163] and field observations, suggesting possible similarities in the microbial consortia in both cases. However, PCB 132 was nonracemic in the cores [156], suggesting that either the microbial consortia and/or environmental conditions affecting microbial activity were different between the laboratory and *in situ*. Much remains unknown about the microbial strains and enzymes involved in PCB anaerobic reductive dechlorination or the factors controlling stereospecificity.

Some pathways for aerobic microbial degradation of chiral PCBs are stereoselective. No evidence of stereoselectivity was observed for degradation of PCBs 45, 88, 91, 95, 136, 144, and 149 by the soil bacterium *Jonibacter* sp. strain MS3-02 [164]. In contrast,

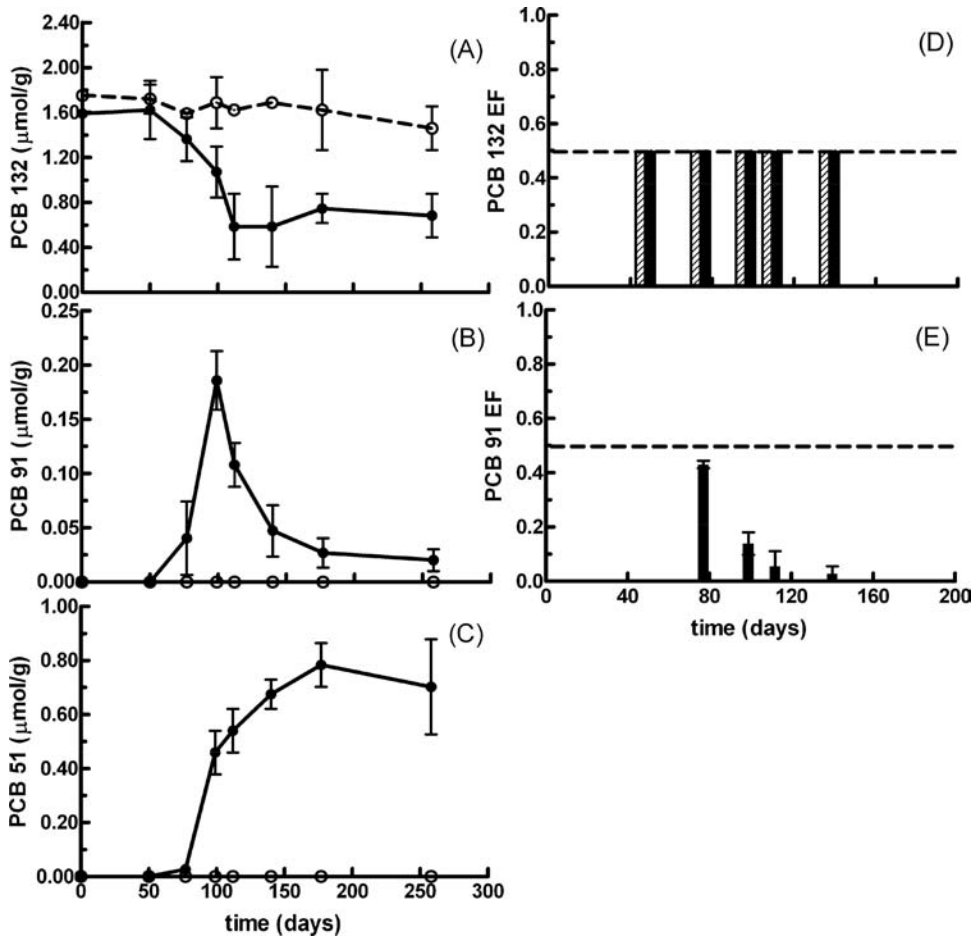

Figure 4.12 Reductive dechlorination of PCB 132 enantiomers and products in laboratory microcosms of Lake Hartwell sediments over time: concentrations (A–C), enantiomer fractions for PCBs 132 (D) and 91 (E). Autoclaved control with racemic PCB 132 added (open circles, crosshatched bars), live treatments with racemic 132 added (filled circles, filled bars). Racemic value of $EF = 0.5$ denoted by dashed line. (Reproduced with permission from Environmental Science and Technology, *Changes in Enantiomeric Fractions during Microbial Reductive Dechlorination of PCB132, PCB149, and Aroclor 1254 in Lake Hartwell Sediment Microcosms*, by Usarat Pakdeesusuk, W. Jack Jones et al., **37**(6), 1100–1107. Copyright (2003) American Chemical Society)

enantioselective biodegradation of PCBs 45, 84, 91, and 95 was demonstrated by five different bacterial strains [165]: gram-negative *Ralstonia eutrophus* H850 and *Burkholderia cepacia* LB 400; and gram-positive *Arthrobacter* sp. strain B1B, *Rhodococcus* sp. strain ACS, and *Rhodococcus globerulus* P6. Gram-negative strains had similar enantiomer preferences, while gram-positive strains had a completely different enantiomer preference pattern. The exception, gram-positive P6, is genetically similar to the gram-negative strains

with regards to biphenyl dioxygenase enzymes [166] and had a gram-negative enantiomer degradation pattern [165]. Thus, dissimilar PCB enzymatic pathways were responsible for the observed results, and chirality can be used to gain an insight into biotransformation mechanisms.

4.4.1.4 Soils and Overlying Vegetation

OC pesticides

The enantiomer distribution of chiral OC pesticides indicates substantial microbial degradation of agricultural soils over the decades since these compounds were actively used. British Columbia agricultural soils were enriched in both (+)- α -HCH and (+)-heptachlor epoxide (EFs of 0.57–0.58 for both) [142, 167] and (–)-oxychlordane (EF range 0.37–0.46) [142]. Subsequent studies there [146] showed enrichment of (+)-*cis*-chlordane and (–)-*trans*-chlordane similar to nearby soils, with EF ranges of 0.51–0.53 and 0.44–0.49, respectively. Enantiomer preference of α -HCH depended on locale, with EFs ranging from 0.35 to 0.55. Nonracemic signatures of heptachlor epoxide, *cis*- and *trans*-chlordane, oxychlordane, and *o,p'*-DDT were also observed in the US Midwestern Corn Belt [35, 143]. Alabama soils had enriched (–)-*cis*- and (+)-*trans*-chlordane and E2-MC-5 [168], with respective mean EFs of 0.48, 0.53, and 0.42 (Equation (4.4) on Beta-Dex 120 [143]) for the three compounds. Soils from farms in Alabama, Louisiana, and Texas had nonracemic amounts of *o,p'*-DDT [169]. Soils of the Pearl River Delta in China had preferential enrichment of (–)- α -HCH, (+)-*o,p'*-DDT, (+)-*cis*-chlordane, and (+)-*trans*-chlordane [170]. Soils with high *p,p'*-DDT concentrations also had racemic *o,p'*-DDT residues, suggesting fresh illegal use of DDT [170]. Enrichment of (+)-*cis*- and (–)-*trans*-chlordane, as typified in soils near Toronto [148] were generally, but not always, observed in soils worldwide [140], as well as in overlying air throughout North America [171, 172], suggesting continual emissions of weathered residues from soils. Likewise, North American air was also enriched in (+)-heptachlor epoxide [171] and (–)-*o,p'*-DDT [171, 172]. On the other hand, α -HCH was enriched in the (–)-enantiomer in air of northeastern Canada and Baffin Island while the (+)-enantiomer was enriched in the eastern US and western Canada [173], reflecting local emissions from soils and waters. Archived UK soils from 1972 to 1990 showed enrichment of (+)-*cis*-chlordane, (–)-*trans*-chlordane, and (+)-*o,p'*-DDT, but no clear temporal trend in EFs [174]. Those authors suggested that relative rates of removal of the enantiomers of these compounds were not consistent with time, possibly due to changes over the decades in the microbial communities with different enantiomer preferences. No differences in EFs for these three compounds were observed between archived soils amended with sludge and unamended soils, suggesting that microbial consortia changes, if any, were unaffected by the amendment [174].

The Connecticut Agricultural Experiment Station is a site of extensive experimentation on chiral chlordanes in soils and plants. An experimental plot there was sprayed with a known amount of technical chlordane in 1960, and was then covered with turf until 1998 [175]. Enrichment of (+)-*cis*-chlordane and (–)-*trans*-chlordane was observed [175], consistent with global trends [140]. Soils with more nonracemic *cis*-chlordane also had more nonracemic *trans*-chlordane [175], suggesting that both isomers were concurrently degraded. Crop plants planted in these soils (e.g. zucchini, cucumber, pumpkin, lettuce, spinach, pepper, tomato) depleted chlordane concentrations in the rhizosphere soils closest to the roots [176] with resulting enrichments in chlordanes in the roots [177]. This

translocation was likely to be due to nonenantioselective uptake by roots rather than degradation by rhizosphere bacteria, as the enantiomer composition in the rhizosphere was unchanged [176]. While both (+)-*cis*- and (-)-*trans*-chlordane were enriched in plant tissues, significant shifts in both isomeric and enantiomer composition of chlordanes occurred, indicating enantioselective degradation and/or translocation within and among plant tissues [176, 177]. Subsequent cultivar experiments on cucumbers and zucchini suggested that xylem sap transport may be enantioselective, given the geometry of aquaporin transmembrane channel proteins and observations of flux dependencies on contaminant size and shape [178]. However, the specific mechanism responsible for enantioselectivity could not be ascertained in that study. Further research is necessary to understand enantiomer-specific uptake of POPs to plant tissues, and hence exposure to POP enantiomers via consumption of vegetation [179], which is not as well understood as bioaccumulation from animal consumption in aquatic and terrestrial food webs.

Spatial trends in soil enantiomer compositions of POPs are currently not well understood. Costa Rican soils were slightly enriched in (+)-*cis*-chlordane and (-)-*trans*-chlordane [147]. However, no correlations were observed between these EFs and fraction soil organic carbon, *trans*-chlordane/*cis*-chlordane ratios, or *trans*-chlordane/*trans*-nonachlor ratios [147]. These observations were consistent with lack of correlation of global *cis*- and *trans*-chlordane soil EFs with soil concentrations or labile/persistent concentration ratios [140], suggesting that EFs alone cannot be used to predict soil degradation rates. Intrinsic soil variability in EFs was observed for α -HCH, *cis*- and *trans*-chlordane, and MC-5 in Scottish soils only meters from one another [146, 180] (Figure 4.13), including reversals of chlordane enantiomer composition between surface soils and deeper soils at some sites (e.g. a *cis*-chlordane EF of 0.51 at the surface and 0.41 at 5 cm depth). This observation is supported by reversals in EF composition

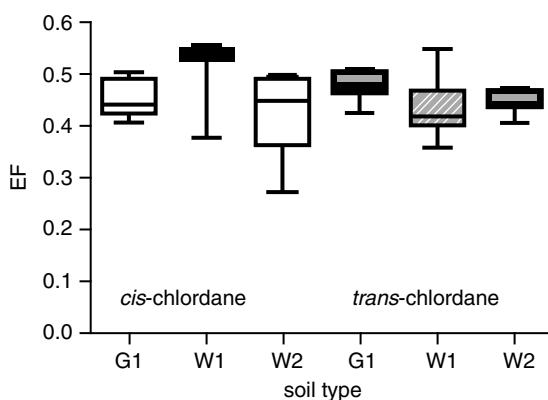

Figure 4.13 Variability in enantiomer fractions (EFs) of *cis*-chlordane and *trans*-chlordane at plots in grassland (G) and woodlands (W1 and W2) in Scotland. Box plot defined as follows: top and bottom of whiskers are maximum and minimum EFs, respectively; top and bottom of box are 25 and 75% percentiles, respectively; line in box is median EF. (Reproduced with permission from Environmental Science and Technology, *Enantioselective Degradation of Organochlorine Pesticides in Background Soils: Variability in Field and Laboratory Studies*, by Perihan Binnur Kurt-Karakus, Jacqueline L. Stroud et al., **41**(14), 4965–4971. Copyright (2007) American Chemical Society)

in PCB-contaminated sediments of Lake Hartwell at different depths [156] and suggests that soil and sediment microbial populations responsible for these EFs were likely to have been influenced by a myriad of other factors [181] including pH, nutrients, temperature, moisture content, redox condition, and vegetation type [178].

PCBs

Soil measurements of chiral PCBs suggest that microbial degradation in this matrix, as with sediments, may take place at concentrations far below previously believed threshold concentrations. Chiral PCB EFs in rural UK topsoils contained nonracemic PCBs 95, 136, and 149 (respective EF ranges of 0.39–0.45 using Equation (4.4) on Chirasil-Dex, 0.52–0.53, and 0.50–0.54) at pg/g concentrations [182]. Soils closer to the city of Birmingham had more racemic EFs [183]. Similar results were observed in forested soils in the greater Toronto region [148]. Grass growing at the UK sites had similar nonracemic EFs for PCBs 95 and 149 as the underlying soils [184]. Such observations are consistent with the hypothesis that soil microbial degradation of PCBs occurred slowly (i.e. on a timescale of years to decades) but appreciably over time [156, 182, 183]. Chirality is thus the only feasible method to detect such biodegradation. While PCB EFs in soils and sediments rarely correlate with concentrations [148], correlations were observed between enantiomer composition and total concentrations of polycyclic aromatic hydrocarbons in Toronto and UK soils. This observation suggests that the PCB contamination at these locales was likely due to recent or ongoing emissions.

Pyrethroids

In laboratory microcosms, *trans*-permethrin was selectively degraded compared to the other diastereomer, *cis*-permethrin, by six bacterial strains [19]. These strains also preferentially biotransformed 1*S*-*cis*-bifenthrin over their antipodal 1*R*-*cis*-enantiomers, which were more toxic to daphnids [19]. Enantioselectivity was more pronounced for *cis*-permethrin than for *cis*-bifenthrin, and was strain-dependent. The (–)-enantiomer of both pyrethroids was preferentially depleted in sediments adjacent to a plant nursery, suggesting that *in situ* microbial biotransformation was enantioselective [20]. Although all enantiomers of permethrin were hydrolyzed quickly in ¹⁴C-labeled experiments in soils and sediments, the degradates of both *cis*- and *trans*-permethrin's *R*-enantiomers were mineralized more quickly than those of the *S*-enantiomer, while degradation products of *cis*-permethrin were more persistent than those of the *trans*-isomer [185]. Enantioselective degradation of fenvalerate in soil slurries has also been reported [83]. These studies underscore how enantiomer-specific biotransformation can affect pyrethroid environmental residues, the toxicity of which is also enantiomer-dependent [18–20].

4.4.2 Enantiomer-Specific Transformation and Processing of Chiral POPs by Biota

Considerable research has been done to date to characterize the chirality of POPs in biota. Among other insights, enantiomer analysis has been used to detect and measure rates of POP biotransformation, to elucidate factors affecting degradation (e.g. age, sex), and to assess predator–prey interactions through enantiomer-specific bioaccumulation. Because biota may stereoselectively process many POPs in an analogous manner, this discussion is organized by organism type: invertebrates, fish, birds and eggs, seals, cetaceans, terrestrial mammals, rodents, and finally humans.

4.4.2.1 Invertebrates

Invertebrates had been thought to have poor capability to biotransform many POPs, as shown by experiment [186–188]. This lack is likely from low CYP abundance and activity. Chirality has shown that while it is likely that most aquatic invertebrates do indeed lack the capacity to biotransform POPs, some species are capable of metabolizing some POPs stereoselectively. This finding is significant, as invertebrates are a major component of lower food webs, and bioaccumulation of nonracemic POPs results in more significant enantiomer-specific exposure and toxicity to predator organisms, including humans.

A number of aquatic invertebrates do appear incapable of biotransforming chiral POPs. The copepod *Calanus hyperboreus* has almost always been observed with racemic proportions of α -HCH, *cis*- and *trans*-chlordane, heptachlor epoxide, oxychlordane, MC-5, and PCBs [189–192], consistent with this hypothesis. While α -HCH in most Northwater Polynya pelagic and benthic invertebrates, including *Calanus*, were nonracemic (EF range of 0.41 to 0.43), these EFs were very similar to that in Polynya waters (EF = 0.45) [137]. Such similarity suggests that nonracemic residues of the invertebrates were due to uptake of microbially weathered α -HCH from the surroundings. Likewise, measurements of nonracemic α -HCH (EF = 0.43) in *Calanus* near Svarbald in the European Arctic were also consistent with this hypothesis [191]. While α -HCH, *cis*-chlordane, MC-5, and *o,p'*-DDT EFs in the amphipod *Themisto libellula* were more nonracemic in benthos specimens compared to pelagic specimens (e.g. α -HCH EFs of 0.35 versus 0.41 and *o,p'*-DDT EFs of 0.58 versus 0.51, respectively), both enantiomer and isomer compositions in this species were similar to the respective surrounding benthic or pelagic waters in all cases [191]. Thus, these observations were consistent with bioaccumulation of weathered residues as the process responsible for nonracemic EFs. Likewise, zooplankton in the Hudson River estuary had slightly nonracemic amounts of PCBs 95 (mean EF = 0.48 using Equation (4.4) on Chirasil-Dex) and PCB 149 (mean EF = 0.52), which were very similar to those in the estuary waters and sediments [194]. These EFs were most likely due to runoff of nonracemic PCBs, weathered by reductive dechlorination, from Hudson River sediments [160]. Krill (*Euphausia superba*) in the Antarctic had nonracemic α -HCH (EF = 0.44) [195], but enrichment of (–)- α -HCH in ocean waters of southern latitudes [131] suggested accumulation of microbially degraded α -HCH as the source of this species.

In contrast, an α -HCH EF of 0.34 was observed for *Mysis oculata* in the Northwater Polynya, a value quite different from both water and sediment EFs of 0.45 and 0.39, respectively [137]. This observation suggests the possibility of *in vivo* enantioselective processing of α -HCH by this species [137]. Likewise, other studies have found nonracemic amounts of α -HCH [111], PCBs [66, 196], α -HBCDD [193], and the musks HHCb, AHTN, ATII, and AHDI [197] in several species of bivalves: blue mussel, *Mytilus edulis*; the freshwater clam, *Corbicula* sp.; the clams *Mya truncate* and *Serripes groenlandica*; and zebra mussel, *Dreissena polymorpha*, respectively. These studies could not determine whether the nonracemity was due to *in vivo* biotransformation and/or uptake of food containing nonracemic residues (e.g. suspended organic carbon collected by these filter feeders). However, racemic PCBs in phytoplankton and mixed zooplankton were observed in Lake Superior, while highly nonracemic EFs of several PCB congeners were found in the opossum shrimp, *Mysis relicta*, and the amphipod *Diporeia hoyi* [198]. Because both *Mysis* and *Diporeia* feed upon those phytoplankton and zooplankton, the most likely explanation

for the shift in enantiomer preference was *in vivo* biotransformation. *In vivo* enrichment of E1-PCB 91 and E2-PCB 95 on Chirasil-Dex, as well as (–)-*trans*-chlordane, was confirmed in laboratory exposures of *Mysis relicta* to sediments with racemic residues [199], with half-lives ranging from 9 to 231 days. (+)-Oxychlordane, the metabolite of (+)-*trans*-chlordane, was formed enantioselectively, proving that biotransformation occurred for this compound [199]. However, it remains unclear what factors (e.g. analyte concentration, organism health, and developmental stage) affect biotransformation of POPs by invertebrates.

4.4.2.2 Fish

OC pesticides and PCBs

Knowledge gained from achiral studies suggested that aquatic organisms, such as fish, are likely to have very limited capabilities to biotransform many POPs due to lower levels and activities of CYP isozymes [200–203] than in mammals or birds. Feeding experiments were ambiguous, with some measuring metabolism [204] and others not [205]. Field studies have inferred POP biotransformation from lower measured biotransformation factors (i.e. lower relative concentrations in predator body residues compared to that in prey), lower concentrations relative to recalcitrant congeners such as PCB 153, or lower retention of congeners expected to be metabolized based on structure–activity relations [206–211]. However, these methods are indirect and do not provide conclusive evidence for *in vivo* biotransformation, underscoring the difficulty in unequivocally detecting biotransformation in aquatic food webs using achiral techniques alone, without the use of stable-carbon or radiolabeled tracers and the expenses involved therein. The lack of observable POP metabolism by aquatic organisms is reflected in modeling of POP patterns in aquatic food webs, where biotransformation is ignored or assumed to be negligible [212, 213].

Chirality has shown that at least some POPs are not likely to be biotransformed by some fish species. Some legacy POPs were racemic in fish, such as the toxaphene congener B7-1453 in cod liver oil [214], as well as *cis*- and *trans*-chlordane, α -HCH, *o,p'*-DDT, and photodieldrin in fish oils purchased from various countries [215]. Arctic cod (*Boreogadus saida*) also had racemic amounts of α -HCH, *cis*- and *trans*-chlordane, U82, MC-5, and MC-7 [190, 216], as well as MC-6 [216] and PCBs [192]. Emerald rockcod (*Trematomus bernacchii*) in the Antarctic also had racemic residues of α -HCH [195].

However, other field measurements of chiral POPs challenged the assumption that fish could not biotransform many such compounds. Initial measurements found nonracemic residues of oxychlordane and heptachlor epoxide in Atlantic salmon (*Salmo salar*) and oil from herring (*Clupea harengus*) [217] and in photo-*cis*-chlordane, U82, and several toxaphene congeners in the salmon [116, 218]. In a similar vein, herring from the Baltic Sea had enrichments of the (–)-enantiomers of α -HCH, *trans*-chlordane, and heptachlor epoxide [219]. Female Atlantic cod (*Gadus morhua*) preferentially accumulated the (–)-enantiomers of both *cis*- and *trans*-chlordane, while the opposite enantiomer of both was preferentially accumulated in males for reasons unknown [220]. Diseases such as M74, responsible for reproductive failure in Atlantic salmon, had little effect on EFs of legacy OC pesticides in affected fish compared to unaffected specimens [221]. Rockeye cod in the Antarctic had average EFs of 0.6 for oxychlordane, but EFs in krill prey could not be measured [195]. Cod liver oils had nonracemic compositions of the same analytes as measured in the purchased

fish oils [215], consistent with nonracemic OC pesticides (except for α -HCH, which was racemic) and PCBs found in NIST Standard Reference Material 1588a, cod liver oil [105]. Nonracemic PCBs were observed in livers of sharks [87, 222] and groupers [87], while Arctic cod in the Northwater Polynya had racemic PCBs [192]. Similar nonracemity in PCBs was also observed for a number of freshwater fish species in the highly contaminated Lake Hartwell reservoir, as well as in streams and rivers throughout the US [196].

The nonracemic chiral POPs observed in many species suggest that these organisms might biotransform persistent POPs to a greater extent than indicated on the basis of studies based on achiral analysis. However, without accurate knowledge of the underlying food web, it is not clear if the nonracemic residues were indeed due to *in vivo* biotransformation or to uptake from prey, or some combination of the two. For some species – flounder (*Platichthys flesus*) from the North Sea [111], herring from the Baltic Sea [219], and Arctic cod in the Northwater Polynya [137] – enrichments of (–)- α -HCH (EF range of 0.44 to 0.47) were similar to those found in surrounding waters. Thus, no evidence of enantioselective bioprocessing was evident if planktonic prey of such species are assumed also to have similar enantiomer compositions, which was the case as measured in the Northwater Polynya [137] but not the other two studies [111, 219]. Similar observations were found for the metabolite heptachlor epoxide, enriched in the (+)-enantiomer in both Arctic waters and Arctic cod [216]. A Georgia estuary heavily contaminated with toxaphene had racemic levels in sediment, but highly nonracemic compositions of B6-923 and B7-1001 in mummichogs (*Fundulus* sp.), strongly suggesting that even low trophic level species could biotransform toxaphene to some extent [151]. In a similar vein, one of the only measurements of the cyclodiene pesticide bromocyclohexane found racemic amounts in German rivers receiving wastewaters, but enrichments of the (+)-enantiomer in bream (*Abramis brama orientalis*), again consistent with *in vivo* biotransformation [223].

A detailed analysis of chiral PCB compositions in the aquatic food web of Lake Superior found that some fish received nonracemic residues from trophic transfer [198]. Conversely, significant differences in EFs between lake herring (*Coregonus artedii*), slimy sculpin (*Cottus cognatus*), and lake trout (*Salvelinus namaycush*) and EFs in their various prey species, indicated that these fish were biotransforming some PCB congeners *in vivo*. Biotransformation rates, calculated from enantiomer mass balances based on known diet compositions, had half-lives on the order of the lifespans of these fish species, suggesting that biotransformation can be a significant sink process for chiral POPs that would otherwise be hard to observe [198].

The capacity for fish to process POPs enantioselectively was demonstrated conclusively through *in vivo* exposure experiments, demonstrating that organisms previously believed incapable of metabolizing POPs are in fact biotransforming these compounds, albeit often slowly [196]. Mummichogs naturally contaminated with toxaphene from a Georgia estuary eliminated one enantiomer of the congener B6-923 twice as fast as its antipode, with half-lives of 6 and 13 days, respectively [224]. This experiment confirmed previous field observations [151]. However, natural attenuation was expected to be slow, given high contamination levels and slow elimination throughput. This study suggested that relatively constant enantiomer signatures observed in wild biota may be due to a steady state between the competing processes of uptake and elimination [224]. In subsequent work, elimination of chlorobornane congeners B6-923 and B7-1001 by mummichogs at 25 °C proceeded at twice the rate at 15 °C [225] by lowering enzymatic activation barriers. Less persistent

congeners were eliminated in racemic proportions by either physical depuration or non-enantioselective biotransformation [225].

Laboratory uptake and depuration experiments on fish without an initial load of POPs also strongly suggest at least some enantioselective detoxification capacity in teleosts. Fingerlings of carp (*Cyprinus carpio*) showed that bioconcentrated chlordanes from waters did not change *cis*-chlordane enantiomer compositions, but did eliminate (–)-*trans*-chlordane preferentially [226]. This elimination was consistent with laboratory exposure experiments with rainbow trout (*Oncorhynchus mykiss*), which did not bioprocess α -HCH and PCB 95 enantioselectively, but did eliminate (+)-PCB 136 and (–)-*trans*-chlordane faster than their respective antipodes [227] with half-lives of up to 375 days. Oxychlordane was formed, confirming biotransformation, but enantiomers were not resolved in that study. While other metabolites were not measured, enantioselectivity was first observed in liver tissue, the main organ of detoxification, suggesting biotransformation. Over half the observed elimination of (+)-PCB 136 from fish was due to metabolism [227]. Both PCBs 95 and 136 have vicinal *meta/para* hydrogen atoms, making them amenable to attack by CYP2B isozymes. It is not clear if CYP2B-like isozymes can be induced in fish [228, 229], but if this degradation was catalyzed by CYP2B, then it is clear that conventional models of predicting CYP-mediated PCB degradation [206–211] do not properly account for enantiomer-specific degradation. Wiberg *et al.* [230] suggested that the difference in degradation of these two congeners could be attributed to changes in chemical assimilation across the gastrointestinal tract from hydrophobicity and steric hindrance. Enrichment of (–)-PCB 84 and (+)-PCB 132 was observed in subsequent dietary exposures for rainbow trout [231]. A follow-up study exposed juvenile trout to mixtures of PCBs similar in congener composition to that found in the Great Lakes, and found similar results for PCBs 95 and 136 along with production of several identified OH-PCBs as well as a number of unidentified OH-PCBs [232]. Another salmonid, the Arctic char (*Salvelinus alpinus*), preferentially eliminated (+)- α -HCH, *o,p'*-DDT, (+)-*cis*-chlordane, (–)-PCB 132, and (–)-PCB 136 [230]. Differences in enantiomer preferences between the two salmonid species [227, 230, 232] were likely to be due to species-specific differences in biotransformation. Heptachlor epoxide was formed non-stereoselectively as a result of *cis*-chlordane degradation [230]. Both PCB 132 and *o,p'*-DDT were nonracemic in char muscle, but not in liver, suggesting possible metabolism of POPs outside the liver [230]. Although MeSO₂-PCBs, the typical end products of PCB biotransformation, have been observed in nonmammalian species, such as sculpin fish [233, 234] that can process parent PCBs enantioselectively [198], stereoisomers of these metabolites have not yet been studied in such biota.

Polycyclic musks

The polycyclic musks HHCB and AHTN were present in significantly nonracemic amounts in fish in ponds filled by wastewater effluent discharge [235]. Rudd and carp had nonracemic levels of HHCB, while these species as well as tench and eel had nonracemic amounts of AHTN [235]. Pond water had racemic levels, suggesting some enantioselective biotransformation of the musks by these fish species. No correlation was observed between fish lipid levels and enantiomer composition. Crucian carp has the most nonracemic amounts of *trans*-HHCB and *trans*-ATII [197]. Enantiomer compositions of musks were species-specific, most likely due to biotransformation, which may have been responsible for lower concentrations in carp compared to tench [197].

HBCDD

In fish, the most abundant HBCDD isomer is the α -isomer, which was enriched in the (+)-enantiomer in bib and whiting liver [58]. However, (–)- α -HBCDD was enriched in herring (*Clupea harengus*) [236] and sole [58], while eel [58] Arctic cod [193] and redfish (*Sebastes mentella*) [193] had racemic α -HBCDD. While fewer EF measurements and greater uncertainties were evident for the other major HBCDD isomers, both (–)- β -HBCDD and (+)- γ -HBCDD were enriched preferentially in fish [58]. None of these species-specific preferences were evident by achiral measurements. Given evidence of isomerization of HBCDD diastereomers by rainbow trout in feeding exposures [63], it is probable that enantiomer-specific bioprocessing of HBCDD occurs in fish. Recently, the HBCDD metabolite pentabromocyclododecene, which is also chiral, was identified in whitefish (*Coregonus* sp.) [237]. While enantiomers were not measured in that study, characterizing the behavior of individual enantiomers of HBCDD degradates will increase our understanding of this current-use chemical.

4.4.2.3 Birds

Birds appear to have much higher enantioselective detoxification capacity on chiral POPs than aquatic organisms. This is particularly the case for α -HCH, as demonstrated by measurements of its enantiomers in birds compared to those in the birds' diet. Eider ducks (*Somateria mollissima*) from the Baltic Sea were enriched in (+)- α -HCH with EFs ranging from 0.62 in kidney to 0.13 in muscle [238]. These values were considerably more nonracemic than in their blue mussel prey (*Mytilus edulis*), which were enriched in the (–)-enantiomer (EF = 0.44 to 0.48) [111], or the waters of the North Sea with EFs from 0.46 to 0.53 [238], suggesting preferential *in vivo* metabolism of (–)- α -HCH by eider ducks. Brain tissue was highly enriched in (+)- α -HCH [111, 239], strongly suggesting enantioselective blood–brain transfer of this chemical. In the Northwater Polynya, low biomagnification factors in seabirds, coupled with racemic α -HCH in Arctic cod prey and nonracemic residues in bird tissues (EF range of 0.65 to 0.97), implied *in vivo* biotransformation by the seabirds [137]. In the Antarctic, Adélie penguins also had enrichments of (+)- α -HCH (EF = 0.58), while their diet, krill and emerald rockcod, had slight enrichments of (–)- α -HCH or were racemic, respectively (EF of 0.44 and 0.49) [195]. Double-breasted cormorants (*Phalacrocorax auritus*) had racemic α -HCH in Lake Superior colonies, but were enriched in the (+)-enantiomer in Lake Michigan, suggesting feeding habitat as a factor affecting enantiomer behavior in this species [240]. Residues were tissue-specific, but not sex- or age-specific, indicating that sexual maturity, aging, and breeding activities did not strongly affect enantiomer composition in this species [240].

Other OC enantiomers behave similarly to α -HCH in birds, with the exception that enantioselective blood–brain transfer has not yet been observed for these other OCs in avians. One of the earliest measurements in birds found nonracemic oxychlordane, U82, and photo-*cis*-chlordanes in a juvenile Adelaide penguin (*Pygoscelis adeliae*), while MC-5 and MC-6 were racemic [116, 217]. In the Northwater Polynya, EFs of chlordanes in seven seabird species were not correlated to concentration or trophic level, but did have nonracemic and species-specific signatures [241]. Some bird species, such as the thick-billed murre (*Uria lomvia*), had greater propensity to biotransform chlordanes, based on a number of lines of evidence including high proportions of the metabolite oxychlordane and

more nonracemic values for this analyte and heptachlor epoxide, another metabolite [241]. The toxaphene congener B7-1000 was identified in nonracemic proportions in skua (*Catharacta maccormicki*), another seabird, suggesting metabolic degradation [242].

The data available to date suggests that PCB metabolism in birds is highly stereoselective. While PCBs 95, 136, and 149 were near racemic in barn swallows (*Hirundo rustica*) in highly contaminated Lake Hartwell, PCB 91 was highly nonracemic [196]. The source of these enantiomer compositions was not determined. Seven seabird species in the North-water Polynya had highly nonracemic compositions of PCBs 91, 95, 149, and 183 [192], with PCB 95 EFs as high as 0.84 (Equation (4.4) on Chirasil-Dex) in ivory gulls (*Pagophila eburnea*) and as low as 0.15 in thick-billed murres (*Uria lomvia*). Many seabirds consumed Arctic cod, which was near-racemic in these PCB congeners, indicating that these seabirds obtained the nonracemic compositions via *in vivo* biotransformation. Enantiomer patterns differed between congeners and among species, indicating highly species-specific, regioselective bioprocessing of PCB atropisomers [192]. However, some species (e.g. glaucous gulls, *Larus hyperboreus*) were at higher trophic levels than marine mammals based on stable nitrogen tissue analysis [241], suggesting that scavenging of seal carcasses could have led to accumulation of nonracemic POPs. Pelican tissues had nonracemic amounts of 4'-MeSO₂-PCB 132 and 4- and 5-MeSO₂-PCB 149 [243], consistent with enantioselective PCB biotransformation capacity in birds.

4.4.2.4 Eggs

Eggs have been used as a biomonitoring tool to assess POP concentrations and trends, as they are a repository for POPs accumulated and degraded throughout the avian food web, although no enzymes are active in undeveloped eggs to metabolize POPs. Eggs of raptors in Norway had highly species-specific nonracemic compositions of *trans*-chlordane (EF range of 0.09 to 0.18), while oxychlordane and toxaphene congener B9-1679 were nonracemic but did not have species-specific compositions (EF ranges of 0.23 to 0.44 for both) [244]. Similarly, nonracemic PCBs were found in eggs of predatory birds from Spain [245] and nonracemic MeSO₂-PCBs were found in guillemott (*Uria aalge*) eggs from Norway [246]. Whole eggs of dippers (*Cinclus cinclus*) from Norway had racemic α -HCH, while that of bird livers was enriched in (+)- α -HCH [247]. However, it was unclear if these nonracemic residues arose from the underlying food web, from maternal transfer to the egg during laying, and/or from microbial action in eggs that were addled or infertile [244, 245]. Confounding interpretation is the fact that whole eggs consist of a number of tissues (i.e. yolk, albumin, embryonic tissue), so measurements of whole eggs cannot be used to determine sources of POP enantiomers in the egg [247].

Laboratory studies and ancillary information collected in field studies addressed the origins of nonracemic POPs in eggs. Racemic toxaphene congeners fed to laying chickens were nonracemic in eggs from *in vivo* biotransformation in mothers, to such an extent that only single enantiomers were found in some bird tissues [78]. Blood plasma of female egg-laying and male glaucous gulls in breeding colonies of Svalbard in the Norwegian Arctic had similar EFs as egg yolk for *cis*- and *trans*-chlordane, oxychlordane, heptachlor epoxide, and PCBs 95, 149, and 183 [248]. This observation suggests that maternal transfer in egg formation and laying is not stereoselective [248]. Slight but significant differences were observed in EFs of PCB 183 and heptachlor epoxide in eggs from different colonies at Svalbard, known to have

different feeding preferences and accumulated contaminant concentrations [248]. This observation suggests that eggs can serve as a biomonitoring indicator of integrated bio-weathering of the underlying food web and can detect changes in that food web structure.

While many brominated pollutants are bioaccumulative in higher organisms, such as birds, little research has been done on their enantiomers in avians. Eggs of predatory birds from Sweden contained only the α -diastereomer of HBCDD [236] with species-specific signatures: white-tailed sea eagles (*Haliaeetus albicilla*) were enriched in (+)- α -HBCDD, guillemots (*Uria aalge*) had racemic residues, while peregrine falcons (*Falco peregrinus*) and common terns (*Sterna hirundo*) were enriched in (-)- α -HBCDD. These signatures were different to the nonracemic signatures (EF = 0.24) found in their herring prey, suggesting enantioselective avian biotransformation and/or uptake [236]. A white-tailed sea eagle (*Haliaeetus albicilla*) egg had an EF of PBB 149 of 0.42, using Equation (4.4) on a β -TBDM column with GC-MS/MS [249]. Chicken eggs had measurable amounts of the HBCDD metabolite pentabromocyclododecene [237], although individual enantiomers were not measured.

4.4.2.5 Pinnipeds

Pinnipeds (e.g., seals, walruses) are a key link in many marine food webs, in that they are commonly found, predate on fish, and are hunted in turn by sharks, polar bears, and Arctic Inuit peoples as part of their traditional diet. In these roles, pinnipeds play a significant role in bioaccumulating POPs and in transferring these contaminant burdens to higher trophic levels. Thus, an understanding of POP dynamics in pinnipeds is important in exposure and risk assessment, and an enantiomer-specific understanding is vital given that pinnipeds bioprocess POPs enantioselectively.

OC pesticides

Chiral chlordanes have been extensively studied in pinnipeds. Some of the earliest measurements quantified nonracemic proportions of the degradates oxychlordane and heptachlor epoxide, as well as the photolysis products photo-*cis*-chlordane and photo-*cis*-heptachlor in tissues of a grey seal (*Halichoerus grypus*) from the Arctic and a harp seal (*Pagophilus greonlandicus*) from Greenland [89, 116, 217]. This quantification was used to validate then-new enantioselective GC/MS-based analytical methods. (+)-Oxychlordane was enriched in harbor seals (*Phoca vitulina*) of Iceland, but (-)-oxychlordane was enriched in grey seals there [250]. Species-specific signatures were observed for chlordane compounds in harbor seals, grey seals, and ringed seals (*Phoca hispida*) from the Baltic Sea [219]. Some reversals in enantiomer preferences among species were evident [219], such as enrichment of (+)-*trans*-chlordane in male harbor seals and enrichment of the (-)-enantiomer in male grey and ringed seals. More nonracemic compositions for most chlordane components were observed in liver compared to blubber, suggesting biotransformation by seals; however, this was not true for U82 and *trans*-chlordane, suggesting that nonmetabolic enantioselective toxicokinetic processes in seals exist [219]. Similar results were observed in ringed seals from Resolute Bay, Canada [216]. In addition, sex-specific enantiomer compositions were found, suggesting that female seals could also process chlordane enantiomers by maternal transfer [216]. An extensive analysis of chlordane compound enantiomers in 199 ringed seals from the Northwater Polynya [251] found that nonracemic residues of *cis*- and *trans*-chlordane, oxychlordane, and heptachlor epoxide in blubber were different from other marine and aquatic biota, suggesting *in vivo* biotransformation by ringed seals. However, EFs of these

compounds did not vary with seal age, sex, or location within the Polynya [251]. Similar results were observed for chlordanes in ringed seals and bearded seals (*Erignathus barbatus*) of the Bering–Chukchi Seas [190]. Grey seals in the Baltic with poor nutritional status also had high contaminant loads and distinctly nonracemic residues of chlordanes, suggesting that starvation triggers the use of fat reserves and consequent release of blubber-sequestered contaminants that are then biotransformed enantioselectively [221].

Of the chiral OCs found in pinnipeds, α -HCH is one of the best studied. Northern fur seals (*Callorhinus ursinus*) from Alaska had enriched (+)- α -HCH in blubber (EF = 0.64) but even more enrichment in the brain (EF = 0.97) [252]. This observation was one of the first to suggest the existence of enantioselective blood–brain barrier transfer for pollutants. Grey seals and harbor seals from Iceland [250, 253, 254], the Arctic, the North Sea, and the Baltic Sea [253] had slight enrichments of (+)- α -HCH in blubber (e.g. mean EF = 0.58 and 0.54, respectively, in Iceland) [254]. However, hooded seals (*Cystophora cristata*) from the Russian Arctic [253] and Weddell seals (*Leptonychotes weddellii*) from the Antarctic [250] preferentially accumulated (–)- α -HCH, indicating species-specific preferences for this compound [253]. Northern fur seals from the Japanese Pacific coast had enrichments of (+)- α -HCH in blubber [240] with no correlation between seal age and enantiomer compositions. However, a temporal trend of increasing ER between 1980 and 1998 (i.e. increasingly greater proportions of (+)- α -HCH) was observed, along with an increase in ER with increasing fish in measured stomach contents (Figure 4.14). Because the seals' diet changed from about 80% fish in 1980 to nearly all fish later on (Figure 4.14), these correlations suggest that dietary variation was responsible for at least part of the observed enantiomer compositions [240]. Ringed seals in the Northwater Polynya had biomagnification factors above unity for HCH isomers along with near-racemic residues of α -HCH, suggesting minimal biotransformation [137, 251]. However, ringed seals in Resolute Bay in the Canadian Arctic also accumulated racemic α -HCH from Arctic cod and had racemic α -HCH in blubber, but also had enrichments of (+)- α -HCH in liver [216]. It is not clear why ringed seals of these two populations processed α -HCH enantiomers in such a different manner.

A number of new toxaphene compounds have been discovered in pinnipeds, beginning with the finding of two racemic congeners in blubber seals in the early 1990s [255]. The congener B8-1412 was isolated from grey seal blubber and positively identified using nuclear magnetic resonance (NMR) and enantioselective chromatography [256], while B7-1000 was likewise isolated and identified and found to be nonracemic in blubber of Weddell seal and elephant seal (*Mirounga leonina*) [242]. Racemic B8-1413 was found in brain tissue of Weddell seals, elephant seals, and leopard seals (*Hydrurga leptonyx*); on the other hand, B8-1412, B8-2229, and B9-1025 were nonracemic in blubber tissues [257]. The nonracemic observations are consistent with *in vitro* enantioselective biotransformation of toxaphene congeners by harbor seal microsomes [258].

PCBs and metabolites

The first measurements of chiral PCBs in mammals found nonracemic PCB 149 on the BGB-172 column used in blubber of harbor seals and grey seals, but no correlation to organism age or sex [250]. Ringed seals of the Northwater Polynya [192] had highly nonracemic PCBs 91 and 95 (mean EFs of 0.06 and 0.85, respectively, using Equation (4.4) on Chirasil-Dex) compared to the racemates for these analytes in their main prey, the Arctic cod. In Baltic Sea grey seals, racemic amounts of PCBs 135, 149, and 174 were found [81]. In contrast, highly

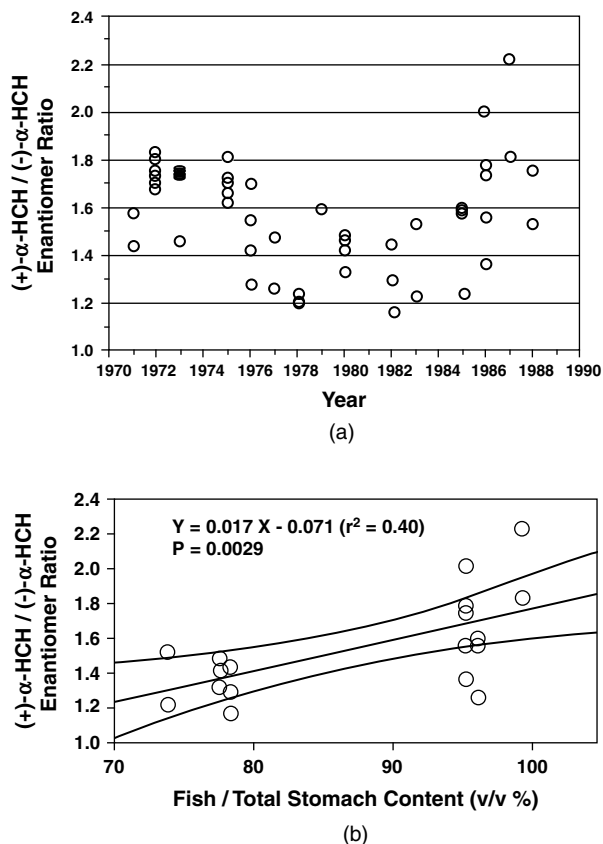

Figure 4.14 Relationship of α -HCH enantiomer ratios (ERs) in fat of adult female northern fur seals from the Japanese Pacific coast with time (A) and feeding habitat based on average stomach content (B). (Reproduced with permission from *Environmental Science and Technology, Enantioselective Accumulation of α -Hexachlorocyclohexane in Northern Fur Seals and Double-Crested Cormorants: Effects of Biological and Ecological Factors in the Higher Tropic Levels*, by Hisato Iwata, Shinsuke Tanabe et al., **32**(15), 2244–2249. Copyright (1998) American Chemical Society)

nonracemic PCBs 132 (EF range of 0.7 to 0.9), and 91 and 95 (EFs of 0.1 and 0.9, respectively, using Equation (4.4) on Chirasil-Dex) were found [81]. Liver had more nonracemic PCBs than blubber, suggesting biotransformation. Otherwise, EF profiles were similar throughout the body of a mother seal and its pup [81], suggesting that no maternal enantioselective transfer had occurred across the placenta, and nor was transport across the blood–brain barrier stereoselective in contrast with results for α -HCH in rats [259].

Methylsulfonyl PCB metabolites are generally highly nonracemic in mammals, and in many cases were found almost entirely as only one enantiomer. Ringed seals formed highly nonracemic 5-MeSO₂-PCB 149 not present in arctic cod, their major prey [260], indicating that seals formed this metabolite from enantioselective formation and/or clearance. Livers of grey seals in the Baltic Sea had much higher MeSO₂-PCB concentrations than lung and

blubber [261], with nearly pure enantiomers as measured (Equation (4.4) on a custom column) in all three tissues for 4-MeSO₂-PCB 91 (EF range of 0.94 to 1), 4'-MeSO₂-PCBs 132 and 174 and 4-MeSO₂-PCB 149 (EF range of 0.99 to 1 for all), and 5'-MeSO₂-PCBs 132 and 174 (EF range of 0.01 to 0.14 for both). In contrast, blubber of seals in captivity had racemic 4-MeSO₂-PCB 149; the species was not identified in that study [243]. Changing the location of the methyl sulfone moiety results in preferential accumulation of 5- and 5'-MeSO₂-PCBs in liver tissue and 4-MeSO₂-PCBs in lung tissue, most likely from selective protein binding [7]. It is likely that such binding is probably enantioselective as well, as suggested by the highly enantioselective residues of MeSO₂-PCBs in seal tissues [261].

Brominated flame retardants

As with birds, little work has been done with brominated contaminants in pinnipeds. Walruses (*Odobenus rosmarus*) from the Canadian Arctic had slightly nonracemic (–)- α -HBCDD for unknown reasons [193]. The only study of chiral brominated flame retardants in pinnipeds reported enantiomer separation of 2,3-dibromopropyl-2,4,6-tribromophenyl ether, the major component of the flame retardant Bromkal 73-5 PE [5]. While this chemical was identified in blubber and brain tissue of hooded seals and harp seals, enantiomer analysis on these tissue extracts were not performed.

4.4.2.6 Cetaceans

Achiral studies have suggested that while cetaceans may be able to metabolize some lightly chlorinated POPs, they have an extremely limited capacity to do so because of lower CYP levels compared to birds and terrestrial mammals [262]. However, early work on chiral POPs suggested, but could not prove, that cetaceans do have some capacity for biotransforming these contaminants. Blubber of harbor porpoises (*Phocoena phocoena*) and white-beaked dolphins (*Lagenorhynchus albirostris*) from the Atlantic were enriched in (+)- α -HCH, with an EF range of 0.52 to 0.80 [253]. This enantiomer was also enriched in 10 cetacean species from the Pacific [263], with EFs ranging from 0.62 to 0.73. The α -HCH EFs differed in Dall's porpoise (*Phocoenoides dalli*) from the Bering Sea (EFs of 0.66 to 0.67) to those in the North Pacific and Japan Sea (EFs of 0.62 to 0.65), suggesting but not proving possible differences in feeding patterns and/or metabolic capacity [263]. Cetaceans found dead in the Mediterranean Sea had racemic levels of PCBs 136 and 174 in blubber and liver tissues, but were enriched in the (+)-enantiomer of PCBs 149 and 176 and the E2-enantiomer on Chirasil-Dex of PCBs 95, 132, and 149 [85, 86]. All these congeners had vicinal *meta/para* hydrogen atoms, making them amenable to CYP2B-like metabolism. However, no correlation was observed between liver PCB concentrations and enantiomer compositions [85, 86]. Some nonracemic PCBs were observed in two NIST reference materials made from cetacean blubber homogenates [105]. However, the origin of the nonracemic PCBs was not clear in any of these studies.

Characterization of enantiomer composition in the food web demonstrated enantioselective detoxification of POPs, including PCBs, in cetaceans. In the Bering–Chukchi–Beaufort Sea area, bowhead whales (*Balaena mysticetus*) had nonracemic amounts of some chiral PCBs, while their *Calanus* zooplankton prey had racemic levels [189]. Given the simplicity of the bowhead whale food chain, these observations indicate that these cetaceans had biotransformed PCB atropisomers enantioselectively. The EFs of PCB 91 were significantly correlated with body length in males only, while those of PCBs 95 and

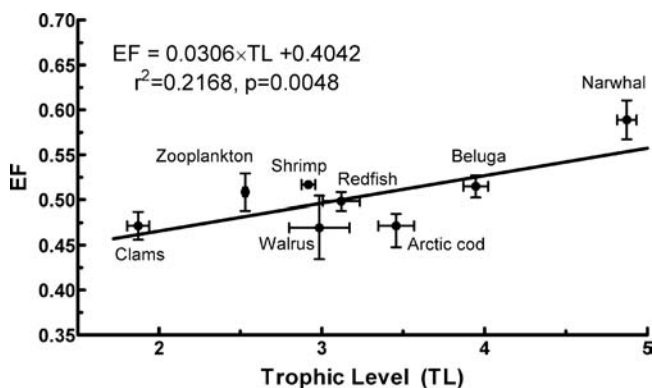

Figure 4.15 Plot of α -HBCDD enantiomer fractions (EFs) versus trophic level within an eastern Arctic food web. Clams, narwhal, beluga, and walrus had EF values statistically different than that of an external standard. (Reproduced with permission from *Environmental Science and Technology*, *Enantioselective Bioaccumulation of Hexabromocyclododecane and Congener-Specific Accumulation of Brominated Diphenyl Ethers in an Eastern Canadian Arctic Marine Food Web*, by Gregg T. Tomy, Kerri Pleskach et al., **42**(10), 3634–3639. Copyright (2008) American Chemical Society)

149 were correlated with lengths for both sexes. Bioaccumulation of these three congeners was influenced by sex, age, and PCB concentration [189]. Likewise, shifts in EFs for α -HCH between *Calanus* and the livers and blubber of bowhead whales suggested some capacity for degradation of this analyte [190]. No enantiomer changes were observed in the bowhead whale food web for the chlordane compounds [190]. The nonracemic enantiomer compositions of PCBs 95, 132, and 149 were correlated with the ratios of PCB 153/PCB 101 in livers of harbor porpoises from the southern North Sea [264]. Because PCB 153 is recalcitrant and PCB 101 is relatively easily metabolized, these correlations indicate that the enantiomer compositions may reflect the degree of detoxification that had occurred in each organism. The harbor porpoise livers also had highly nonracemic compositions (all EFs using Equation (4.4) on Chirasil-Dex) of 5'-MeSO₂-PCBs 132 and 174 (EFs of 0.07 to 0.23), 5-MeSO₂-PCB 149 (EF < 0.20), 4-MeSO₂-PCB 149 (EF > 0.94), and 4'-MeSO₂-PCB 174 (EF > 0.73) [265], with concentrations up to 175 times that of the parent congeners. While biotransformation is a likely reason for the observed methylsulfonyl PCB EFs, selective retention could not be ruled out as a possibility [265].

Very little research has been done to characterize current-use POPs in cetaceans. Atlantic white-sided dolphins (*Lagenorhynchus acutus*) found stranded on the US east coast had α -HBCDD similar median EFs in blubber and liver of 0.44 and 0.42, respectively, indicating no tissue-specific stereoselectivity at least for those compartments [266]. Older animals did seem to have more nonracemic α -HBCDD residues, as EFs correlated with concentration and with animal length [266]. It is possible that younger animals had proportionally more of the (+)-enantiomer of α -HBCDD from maternal transfer, through placental transfer and/or lactation, which then shifted to enrichment of (–)- α -HBCDD from the diet afterwards [266]. However, no data exists yet to support or refute this hypothesis. In the Arctic, (–)- α -HBCDD biomagnified from zooplankton to fish to narwhals (*Monodon monoceros*) and beluga

whales (*Delphinapterus leucas*) to a greater extent than the (+)-enantiomer (Figure 4.15), but it is not clear if this observation was due to enantioselective metabolism [193].

4.4.2.7 Terrestrial Mammals

The few field investigations on the toxicokinetics of chiral OC pesticides in terrestrial mammals have shown that the species extensively studied – polar bears (*Ursus maritimus*), Arctic foxes (*Alopex lagopus*), and wolverines (*Gulo gulo*) – possess a relatively high capacity to degrade these POPs.

All observations of chiral POPs in polar bears indicate that they have high metabolic activity towards POPs, with considerable stereoselectivity. A specimen captured in Iceland had nonracemic amounts of α -HCH in liver (EF = 0.69) and adipose tissue (EF = 0.52), as well as oxychlordane (EF range of 0.55 to 0.57) and the chlorobornane congeners B8-1413 and B9-1679 (EFs of 0.63 and 0.58, respectively, using Equation (4.4) on β -BSCD) [267]. The OC residues were dominated by recalcitrant analytes (e.g. PCBs 153 and 180), suggesting active biotransformation. These observations were consistent with subsequent analysis of polar bears taken from an Inuit hunt at Resolute Bay in the Canadian Arctic [216]. Livers and adipose tissues of these specimens had highly enantioselective residues of α -HCH (EF range of 0.6 to 0.8), as well as the chlordanes typically studied with EFs of up to 0.95 observed [216]. These enantiomer compositions were considerably different than those of arctic cod and ringed seals, the other main species in the polar bear food chain, indicating stereoselective biotransformation by polar bears. Enantiomer-specific bioaccumulation factors indicated that oxychlordane was formed by ringed seal prey and metabolized by polar bears nonenantioselectively. The enantiomer composition of MC-7 and heptachlor epoxide differed among sexes, suggesting possible stereoselective effects of lactation in females, while the enantiomer compositions of MC-6, U82, and oxychlordane was significantly correlated with the age of male bears [216]. In polar bears, only one enantiomer of 5-MeSO₂-PCB 149 was found [260]; at least some 4- and 5-MeSO₂-PCBs 91 and 149 in this species were due to *in vivo* biotransformation, while both 4'- and 5'-MeSO₂-PCB 132 came from consuming seals with these congeners. These EFs were similar to those observed in harbor porpoises [265] in both magnitude and direction, and are consistent with highly stereoselective formation and/or retention.

As with polar bears, wolverines and Arctic foxes also appear to have sizable capacity for biotransforming POPs, as evidenced by enantiomer analysis. Wolverines captured from Iceland and the Canadian Arctic had enrichments of (–)-PCBs 136 and 149 in livers, with mean EFs of 0.41 and 0.46, respectively [268]. While these enrichments were similar to those of α -HCH (mean EF of 0.42) and heptachlor epoxide (mean EF of 0.55), they were not as stereoselective as those of *trans*-chlordane (mean EF of 0.65) and oxychlordane (mean EF of 0.71) [268]. Populations of Arctic foxes in Iceland feeding mostly on marine mammals had much higher POP concentrations in liver tissue than those with a terrestrial diet, but had similar enrichments of (+)-chlordane [267]. As with wolverines, Arctic fox livers [268] had modest enrichments of (–)- α -HCH, (+)-PCBs 136 and 149, and E1-PCB 95 on Chirasil-Dex, with mean EFs of 0.41, 0.48, 0.54, and 0.55 respectively. These enrichments were again minor compared to that of the OC compounds, which had mean EFs of 0.61 for *cis*-chlordane, 0.89 for *trans*-chlordane, 0.68 for oxychlordane, and 0.73 for heptachlor epoxide. Depletions of labile analytes compared to recalcitrant compounds

suggested significant biotransformation by these species; however, low concentrations of many compounds suggested the possibility of significant nonenantioselective biotransformation [268]. Metabolite measurements need to be taken to substantiate this hypothesis.

Although few analyses have been made of chiral POPs in conventional foods [74], one study did find nonracemic α -HCH in sheep [239]. Another found enrichment of (–)- α -HCH in pork tissues [269], with increasing nonracemity in fat, then muscle, then liver, then brain (i.e. from enantioselective blood–brain barrier transfer [259]).

4.4.2.8 *Rodents*

OC pesticides

Laboratory exposure experiments on rodents have revealed considerable insights on the toxicokinetics of chiral POPs. One early such study found predominantly one enantiomer of heptachlor epoxide metabolite from the incubation of heptachlor with rat liver homogenate [116], indicating that the mixed-function oxidase system can detoxify POPs in a highly stereoselective manner. *In vivo* exposures of α -HCH to rats [259] resulted in highly stereoselective α -HCH in brain (EF range of 0.74 to 0.93) compared to blood, liver, and fat, with mean EFs of 0.49, 0.44, and 0.56, respectively. These results were consistent with the highly nonracemic α -HCH residues observed in brains of other organisms in the field, including neonatal fur seals [252], sheep [239], harbor seals [270], and double-breasted cormorants [240]. Animals pretreated with the potent CYP2B inducer phenobarbital and then sacrificed had decreased α -HCH concentrations in liver slices exposed to the racemate, but no concentration change in brain slices [259]. Both liver and brain slices from pretreated animals showed slight enantioselective enrichment after exposure to racemic α -HCH, with mean EFs of 0.43 and 0.53, respectively [259]. These results indicate that rat livers preferentially biotransformed (+)- α -HCH *in vitro* and *in vivo*, but that brain tissues could only accumulate this enantiomer *in vivo* and not from other tissues. Thus, it is highly likely that transport of α -HCH across the blood–brain barrier in rats and the other mammals is highly stereoselective. In contrast, rats exposed to several toxaphene congeners showed rapid nonenantioselective elimination of the B7-515 congener, but stereoselective elimination of B8-1413, B9-1679, and B9-1025 with EFs that did not significantly differ among tissues of brains, adipose, and livers [271]. Thus, no stereoselective blood–brain barrier transport was evident for chlorobornanes, unlike the case with α -HCH.

Sex differences in POP toxicokinetics have also been noted. Female rats initially metabolized *trans*-chlordane to racemic oxychlordane, which later became enriched in the (–)-enantiomer post-exposure [272]. On the other hand, male rats immediately degraded *trans*-chlordane enantioselectively to (–)-oxychlordane [272]. Both sexes preferentially depleted (–)-*trans*-chlordane, as well as (+)-oxychlordane in organisms individually exposed to oxychlordane, *trans*-chlordane, or achiral *trans*-nonachlor. These results supported the hypothesis that although CYP3A induction in rats was not sex-dependent, CYP1A1 induction was [272]. More research remains to be done to elucidate the stereoselectivity of CYP induction and its effects on the metabolism of POPs.

PCBs

The distribution of chiral PCBs in rodents, as with chiral OC pesticides, is enantioselective. Female C57B1/6 mice injected interperitoneally with PCB 84 rapidly distributed both

enantiomers throughout the body, with an enrichment of (+)-PCB 84 in brain, liver, lung, and heart tissues after three days and an enrichment of this enantiomer in the kidney after six days [273]. Spleen tissue had racemic PCB 84, while brain tissue had the most nonracemic EFs consistent with the enantioselective transfer of α -HCH across the blood–brain barrier of rats [259]. No significant differences were observed in EFs between days three and six, suggesting that whatever processes were responsible for the observed enantioselectivity (e.g. biotransformation, excretion, and/or differential tissue retention) occurred during the initial distribution. In similar experiments, this strain of mice also enriched (+)-PCB 136 enantioselectively in adipose, spleen, kidney, liver, brain, uterus, and testes tissues [274]. Animals given PCB 136 via oral administration generally had more nonracemic residues by roughly 0.1 EF units [274], indicating that route of exposure affects enantiomer-specific toxicokinetics. However, absorption processes did not appear to be enantioselective, as EFs of PCB 136 in mice tissues did not change with increasing dietary fat [275]. Enantiomer composition in feces appeared to depend at least in part on whether residues in contaminated food were absorbed through the gastrointestinal tract [275]. In female mice, enrichment of (+)-PCB 136 decreased with increasing dose (2–50 mg/kg body weight) of the racemate, suggesting a saturation of the enantioselective processes in the mice [276]. *In vitro* experiments showed that (+)-PCB 136 bound more strongly to mouse CYP isozymes than (–)-PCB 136 [277]. Binding was inhibited by CYP2B antibodies, indicating that CYP2B isozymes were involved [277]. However, enantioselectivity of PCBs did not change in mice exposed *in vivo* to CYP2B or CYP3A inducers [278], indicating that enantioselective bioprocessing of PCBs was not due solely to CYP-mediated biotransformation. Exposure concentration has not been assessed in most toxicokinetic experiments of chiral POPs, and need to be further considered.

Similar results were observed in analogous rat exposures [278], in which animals exposed to the racemic PCB technical formulation Aroclor 1254 were enriched in E1-PCB 95 on Chirasil-Dex and (+)-PCB 149 in adipose, liver, and skin. Enantiomer reversal, such as (–)-PCB 149 enrichment in blood, was also found. However, only E2-PCB 95 on Chirasil-Dex was enriched in rats exposed to extract with racemic PCB 95 from a soil contaminated with Chlorophen, another formulation, suggesting that differences in congener distributions and concentrations affect enantioselective toxicokinetics.

PCB metabolites

The species-specific, highly nonracemic signatures of MeSO₂-PCBs observed in the field for marine and terrestrial mammals are consistent with their *in vivo* formation in laboratory exposures. Rats dosed with Clophen A50, a technical PCB mixture, produced MeSO₂-PCBs highly enantioselectively. Enantiomer preferences were reversed for 4-MeSO₂-PCB 149 between lung tissues, compared to adipose and liver tissue [280]. Parent PCB compounds were not analyzed. In another experiment, rats preferentially depleted (–)-PCB 132 on Chirasil-Dex and preferentially formed the *R*-enantiomers of 4'- and 5'-MeSO₂-PCB 132 [281]. While enantioselective metabolism was shown, the authors suggested that both isomers of MeSO₂-PCB 132 may be retained enantioselectively by strong binding to liver and lung proteins [281]. This hypothesis has not yet been verified. Rat liver hepatocytes transformed PCB 149 nonstereoselectively *in vitro*, but degraded 5-MeSO₂-PCB 149 in a highly stereoselective manner [282] consistent with the previously reported *in vivo* results [280].

Dozens of OH-PCBs have been found in biota [7] and in surface waters and precipitation [283]. However, only one congener, 4-OH-PCB 187, that can be a precursor of a chiral PCB congener [7] has been positively identified in environmental field studies. This congener is one of the most common OH-PCBs found, and is a product of PCB 183 hydroxylation followed by a 1,2-chlorine shift. Given the many findings of nonracemic PCBs in many biota previously discussed and the production of highly nonracemic chiral MeSO₂ metabolites, it is likely that hydroxylated chiral PCBs are also formed. This hypothesis was demonstrated by *in vitro* degradation of chiral congeners by rat CYP2B1 isozymes [284]. Preferential elimination was observed for E2-PCB 45 on Cyclosil-B, E1-PCB 91 and E2-PCB 95 on Chirasil-Dex, (–)-PCB 84, (–)-PCB 132, and (+)-PCB 136. Using nonenantioselective GC coupled to high mass resolution mass spectrometry, degradates corresponding to the exact mass of the respective OH-PCB degradates of these congeners were identified; two pentachlorobiphenylol isomers were found for PCB 95. While the exact isomers of these metabolites are unknown, at least some of the many unidentified OH-PCBs in previous studies [7, 283] could have been formed from biotransformation of chiral parents, perhaps also in nonracemic proportions. This was demonstrated recently, as rats exposed to racemic PCB 136 *in vivo* formed 3-OH-PCB 136 and 3-OH-PCB-150 in nonracemic proportions [6]. The latter OH-PCB is a 1,2-chlorine shift product of PCB 136 and is also chiral. Those authors have synthesized a number of authentic OH-PCB congeners corresponding to chiral PCB Phase I metabolites [6] to enable further studies on stereoselectivity of chiral PCB metabolism. It is not yet clear if the OH-PCBs are formed or degraded enantioselectively, and other factors affecting CYP-mediated enzymatic degradation of PCBs (e.g. congener or enantiomer inhibition, Michaelis–Menten kinetics) are currently unknown. No enantiomer-specific studies have yet been conducted for other PCB metabolites.

Pyrethroids

Stereoselective toxicokinetics of pyrethroids was observed in rodents. Rats injected with a racemic dose of θ -cypermethrin had much lower amounts of the (+)-enantiomer compared to the (–)-enantiomer in plasma, heart, liver, kidney, and fat tissues. The authors suggested rapid interconversion of (+)- α S,1R,3S-cypermethrin to its antipode (–)- α R,1S,3R-cypermethrin in plasma, but no reverse conversion of the (–)-enantiomer back to the (+)-enantiomer. This hypothesis was criticized [285] as implausible, as three separate epimerization reactions would be necessary for conversion of (+)- α S,1R,3S-cypermethrin to (–)- α R,1S,3R-cypermethrin. However, the results do indicate significant enantioselectivity in the *in vivo* processing of cypermethrin by rats, but is not clear to what extent this enantioselectivity was from biotransformation or from tissue-specific redistribution. The latter was suggested by the data [84] consistent with the highly enantioselective screening of α -HCH by the rat blood–brain barrier [259].

4.4.2.9 Humans

Few studies have been conducted on chiral POPs in humans, for obvious reasons. The handful of measurements made has been on breast milk, blood, feces, or tissues that can be obtained ethically. The chlordane metabolites heptachlor epoxide and oxychlordane were found in nonracemic proportions in human adipose tissue in early studies [116, 217], with an

approximate EF of 0.67 (Equation (4.4)) for both on the custom column used. Placentas from 112 Finnish newborn boys had more racemic EFs for α -HCH and *o,p'*-DDD with increasing contaminant concentration [286], which suggested that monitoring of placentas could be useful for accessing POP trends, including enantiomers, in human cohorts. Human milk had EFs of 0.31 to 0.45 for PCB 132 (Equation (4.4) on Chirasil-Dex) [69]. Some enantioselectivity was observed for other chiral PCB congeners in human milk samples from some women but not others, with no obvious pattern [76]. Several heavily chlorinated toxaphene congeners were also nonracemic and different from reference standards in human milk, with EFs (all Equation (4.4) on BGB-172) of 0.58 to 0.70 for B8-1945, 0.58 to 0.61 for B9-1679, and 0.39 to 0.47 for B9-2206 [287]. Adipose tissues had more nonracemic B9-2206 (EF of 0.30 to 0.32) than milk [287]. Livers of cadavers from Belgium had mostly racemic α -HCH [288]. Five individuals had near-racemic proportions of PCBs 95, 136, and 149 in brain, liver, kidney, and muscle. However, six individuals had nonracemic amounts in liver tissue, with PCB 132 EFs of 0.52 to 0.68, PCB 136 EFs of 0.41 to 0.49, and PCBs 95 EFs (Equation (4.4) on Chirasil-Dex) of 0.56 to 0.74 for reasons unknown [288]. Human feces from the UK had racemic PCB 95 in eight samples, but were enriched in E2-PCB 95 in two samples [184]. The limited enantioselectivity of PCBs in many human tissues is consistent with *in vivo* degradation experiments, in which human CYP2B6 only degraded PCB 45 enantioselectively [284]. However, species-specific effects were observed, as E1-PCB 45 was preferentially transformed in comparison with rat CYP2B1, which preferentially degraded E2-PCB 45 [284]. Methylsulfonyl PCB metabolites were highly nonracemic in humans, as with other mammals, with *meta*-substituted congeners (i.e. 5'-MeSO₂-PCB 132 and 5-MeSO₂-PCB 149) enriched in lung in highly nonracemic proportions [289]. Other studies, however, targeting MeSO₂-PCB enantiomers did not detect any [243]. In human serum, (-)- α -HBCDD was dominant, with an EF of 0.2 [290]. Unlike the case of other organisms, it is not clear yet whether enantiomer residues in humans were due to *in vivo* metabolism or dietary uptake.

4.5 Chirality to Quantify Rates of Biotransformation

Chirality cannot only detect biotransformation but can also quantify it. This is particularly significant in situations for which such determinations are difficult or impossible, either because of intrinsic variability in concentrations and fluxes of POPs, and/or because biotransformation is slow compared to other processes such as air–water exchange and can therefore be masked. A key issue in assessing future trends of POPs is the need for accurate and reliable indicators of degradation, for which biotransformation may be important if abiotic transformation processes are also slow. Measurement of slow biotransformation is essential in determining the long-term fate of persistent POPs from the environment. Decreases in POP concentrations after banning of these compounds have been observed in the 1980s in water [291], fish [292–295], bird eggs [296], and sediments [158, 159, 297] in the Great Lakes and in US rivers [298]. Multimedia modeling has also suggested decreases in various environmental media in the Great Lakes [299, 300]. However, the decline has been observed to stop in the 1990s in the Great Lakes [301] and the Canadian Arctic for some POPs [296]. With the difficulties inherent in estimating biotransformation from achiral analysis, it is clear that future decreases in levels of

POPs will be difficult if not impossible to ascertain in this manner, particularly in field studies.

Enantiomer-specific rates of biotransformation, based on using EFs to determine concentrations of individual enantiomers, have been determined in a number of laboratory and field experiments, as previously discussed: bench-scale anaerobic biotransformation of α -HCH in activated sludge [132], elimination of toxaphene congeners in mummichogs taken from a contaminated estuary [224], and microbial degradation of α -HCH within the Arctic Ocean water column [127]. Alternative methods have also been proposed, particularly for assessing bioaccumulation of POPs in fish. A curvilinear relationship has been observed between the octanol–water partition coefficient ($\log K_{ow}$) of recalcitrant POPs and their persistence in fish, with increasing half-lives to $\log K_{ow}$ of about 7, followed by decreasing persistence from resistance to mass transfer of superhydrophobic POPs across the gastrointestinal tract [302]. Chemicals with less persistence than that predicted by the curvilinear relationship are likely to have been biotransformed, as has been measured for several chiral OC pesticides and PCBs [231, 232]. However, these methods are more problematic to use in field studies, as a plethora of abiotic processes can also affect measured enantiomer concentrations.

An expression was introduced [227] to describe first-order biotransformation rates based on enantiomer compositions over time:

$$EF = \frac{1}{1 + \frac{(-)_o}{(+)_o} e^{k_m t}} \quad (4.6)$$

where t is time, $(+)_o$ and $(-)_o$ the initial concentrations of the (+) and (–) enantiomers, respectively, and k_m the minimum biotransformation rate constant, calculated by assuming EF changes were due solely to transformation of one enantiomer only. If transformation of both enantiomers occurs, as is likely, then the rate would be higher than k_m . Thus, the calculated rates are minimum estimates. Using Equation (4.6), rate constants were calculated for biotransformation of PCBs and OC pesticides in exposure experiments to aquatic invertebrates [199] and fish [227, 232], as well as *in situ* biotransformation rates of fish in Lake Superior [198]. The rates obtained by this method were in reasonable agreement with those calculated by differences in persistence from the curvilinear relationship [232].

The rate constants calculated by EF profiles (Equation (4.6)) are necessarily crude as several assumptions must hold: the initial enantiomer composition is known, only a single stereoselective reaction is active, and the amount of time over which transformation takes place is known. These assumptions may not necessarily hold. For example, for reductive dechlorination of PCBs in sediments, it is possible for degradation to take place upstream followed by resuspension and redeposition elsewhere [156, 194]. The calculated k_m is an aggregate of all reactions, enantioselective or otherwise, involving the chemical in question. This includes degradation and formation reactions, so more than one reaction will confound results. Biotransformation may not follow first-order kinetics (e.g. no lag phase is modeled). The time period may be difficult to estimate; for example, in the Lake Superior chiral PCB study, the organism's lifespan was used [198]. Likewise, in the Lake Hartwell sediment core PCB dechlorination study, it is likely that microbial activity stopped before the time periods selected [156]. However, it should be noted that currently all methods to estimate biotransformation rate constants in field studies are equally crude [156].

The ability of chirality to assess biotransformation could lead to more accurate assessments of POP food web modeling and permit more precise determination of the extent of degradation and ‘virtual elimination’ of POPs to support Stockholm Convention goals.

4.6 Chirality as a Tool for Pollutant Source Apportionment

Chirality has been used to distinguish among sources of chiral pollutants to environmental compartments, such as the atmosphere or natural water bodies. Because partitioning processes between environmental media (e.g. deposition, volatilization) are physical processes, they are not likely to be enantioselective. Thus, if the enantiomer compositions of a chiral pollutant differ among environmental compartments, then a comparison of enantiomer signatures of different compartments can help to identify pollutant sources. The contribution of two sources to the environmental compartment of interest can be assessed quantitatively [303]:

$$F_a = \frac{(ER_{\text{mix}} - ER_b)(ER_a + 1)}{(ER_a - ER_b)(ER_{\text{mix}} + 1)} \quad (4.7)$$

where F_a is the fraction of the chemical from source a , ER_a and ER_b are the ERs of sources a and b , respectively, and ER_{mix} the ER of the mixture in the environmental compartment. A simpler version uses the EFs of each source (EF_a and EF_b , respectively) and the environmental compartment’s mixture (EF_{mix}) [107]:

$$F_a = \frac{EF_{\text{mix}} - EF_b}{EF_a - EF_b} \quad (4.8)$$

4.6.1 Air–Terrestrial Surface Exchange

Organochlorine pesticides have long been used for agricultural purposes. While pesticide POPs are no longer applied to crop fields in countries in which they are banned, residues from past applications remain. These residues, which may have been present in soils for decades, may have been degraded by microbial activity and could thus be nonracemic. If these residues were to be transferred to other environmental media (e.g. volatilization from soil to air), then the enantiomer composition in the other medium would reflect the original source. Thus, ‘old’, biochemically weathered sources of POPs could be distinguished from ‘new’, unweathered sources that would be racemic. In addition, nonracemic sources of POPs could be distinguished from each other if each had arisen from biochemical degradation pathways that had different stereoselectivities, as has been observed [156, 165].

The potential for OC pesticide enantiomers to be used for air–surface source apportionment was first suggested by Finizio, Bidleman, and Szeto [167], who found an air concentration gradient with the same enantiomer composition (EFs of 0.54 to 0.57 for α -HCH and 0.59 for heptachlor epoxide) up to 1.4 m above British Columbia agricultural soils with the same EFs (Figure 4.16). The subsequent measurements of nonracemic α -HCH, *cis*-chlordane, and *trans*-chlordane in these soils [146] indicated that local and regional air burdens of these pesticides were influenced more by agricultural emissions than by trans-Pacific transport from China and India where these compounds are still

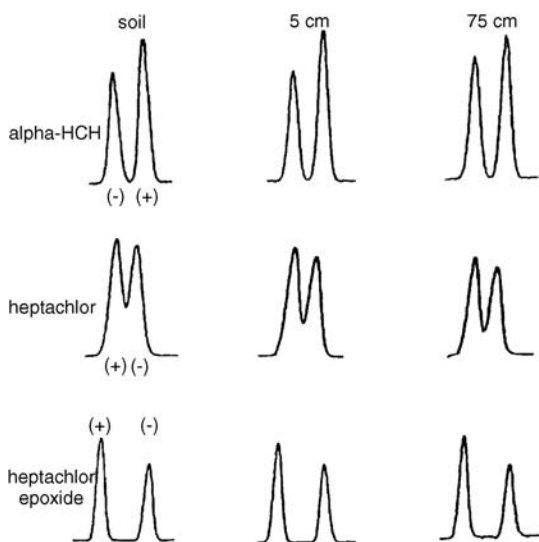

Figure 4.16 Gas chromatogram traces of the enantiomers of α -HCH, heptachlor (HEPT), and heptachlor epoxide (HEPX) in soil and overlying air at a British Columbia farm. (Reproduced with permission from *Chemosphere, Emission of chiral pesticides from an agricultural soil in the Fraser Valley, British Columbia*, by A. Finizio, T. F. Bidleman and S. Y. Szeto, **36**(2), 345–355. Copyright (1998) Elsevier)

used [304, 305]. Indeed, DDT concentrations in air overlying contaminated British Columbia agricultural soils were orders of magnitude higher, at 140 and 880 pg/m^3 for p,p' -DDT and p,p' -DDE, respectively [146], than those in background North American continental air (1–40 pg/m^3 for each compound) [172] and comparable to those found in Central America (440 and 220 pg/m^3 in Belize) [172], where DDT was used until fairly recently [146]. However, DDT in air was racemic and soil EFs were not fully characterized, so it is not clear from enantiomer analysis alone that the same trend followed as for the other pesticides [146]. Strong air concentration gradients above these soils were subsequently measured [306] and DDT fugacity fractions (ff) quantified:

$$ff = \frac{f_{\text{surface}}}{f_{\text{surface}} + f_{\text{air}}} \quad (4.9)$$

where f_{surface} and f_{air} are surface and air chemical fugacities, respectively. Values of ff above 0.5 indicate net volatilization. Fugacity fractions for DDT ranging from 0.42 to 0.91 were found using air concentrations immediately above the soil [306]. Given the precision on ff used in that study, this measurement indicates net volatilization. An average half-life for volatilization over 200 years was calculated [306], showing that DDT will continue to be a source to the atmosphere for a long time in the absence of other sink processes.

Similarly, the nonracemic signatures of heptachlor epoxide, *cis*- and *trans*-chlordane, oxychlordane, and *o,p'*-DDT in soils of the US Midwestern Corn Belt [35, 143] were

correlated with nonracemic air concentrations that decreased with increasing height above the soil [144]. Indoor air was ruled out as a potential source to the Midwestern atmosphere, as air from homes in which chlordane was applied as a termiticide was racemic [168, 307], consistent with little degradation of this insecticide within building foundations. However, air in Alabama had racemic proportions of *cis*- and *trans*-chlordane and MC-5, compared to the nonracemic EFs observed in the soils there [168]. This observation suggests that emissions from termiticide-treated homes may be more important in Alabama in contributing to air burdens there. Little influence of urban sources is expected at rural and agricultural sites [308]. Extracts from the Midwestern soils with nonracemic heptachlor epoxide [143] were mixed in varying proportions with a racemic standard to evaluate Equation (4.7) [303], from which Equation (4.8) was based [107], and to show that prior mathematical expressions for source apportionment were flawed [118, 120, 128]. Significant correlations between soil and overlying air EFs of *o,p'*-DDT in farms from Alabama, Louisiana, and Texas suggested volatilization as the source of DDT to the air at those locales, an observation supported by calculated fugacity fractions indicating net volatilization [169]. However, *o,p'*-DDT was nonracemic in Mexican soils but racemic in overlying air [309]. In conjunction with varying fugacity ratios, this data suggests that DDT in Mexican air is a combination of re-emission of aged sources as well as ongoing regional use of DDT [309]. Flux chambers to sample air directly over soils were used to confirm that essentially all of the atmospheric emissions of *cis*- and *trans*-chlordane was from soils at two agricultural sites in southern Ontario [310]. This sampler was used to compensate for the large propagated errors for fugacity fractions, which has made it difficult to ascertain soil–air equilibrium and direction of exchange [169, 310]. Chlordane fluxes from the treated plot at the Connecticut Agricultural Experiment Station showed that volatilization continued long after application, at rates that depended on temperature and on soil cultivation [311].

While agricultural soils now have nonracemic OC pesticide residues and emit these nonracemic compositions to the atmosphere, this was not necessarily always the case. Archived extracts of air samples collected in Sweden, Slovakia, and Iceland between in the early 1970s had racemic *cis*- and *trans*-chlordane [138]. This observation suggests that those residues were released either from fresh emissions, as these compounds were in active use at the time, and/or they were volatilized from racemic residues in soil. The former hypothesis is more likely, given the EFs of these compounds in sediment cores, which were racemic in the 1950s but less so after that point, including the 1970s [138, 139].

Since the production of PCBs ceased in the late 1970s in North America and Europe, current atmospheric sources of PCBs are believed to be predominantly from volatilization from contaminated environmental surfaces such as soil [312–314] and water [291, 315]. However, emission from existing PCB technical mixtures (i.e. capacitors, transformers, construction materials) may also contribute to atmospheric contamination [316, 317]. The use of PCB atropisomers for source apportionment was first demonstrated by Robson and Harrad [182], who observed that nonracemic soil EFs for PCBs 95, 136, and 149 were statistically different from racemic EFs of all three congeners in the overlying air. In contrast to chiral OC pesticides, the source of atmospheric PCBs was thus not due to volatilization from the soil, but from emission of unweathered PCBs remaining in use. In subsequent work [318], PCB concentrations of indoor air in the West Midlands of the UK had not changed significantly over the past 10 years. Both indoor and outdoor air had

racemic or near-racemic PCB compositions [183, 184]. However, EFs of soil were nonracemic in the rural regions outside Birmingham city center [183]. These results suggest that ventilation of indoor air from the urban center, and not volatilization of contaminated soil, was the source of atmospheric PCBs to this region of the UK. This observation was further supported by other studies that observed decreasing PCB with increasing distance from urban centers [319, 320], suggesting that identification and control of unweathered PCB sources (e.g. PCB-containing building sealants, leaking transformers with PCB-bearing capacitor oil) would be the most effective means of lowering urban atmospheric PCB concentrations. Asher, Wong, and Rodenburg [194] observed that PCBs in the air overlying the Hudson River Estuary at New York City was racemic, consistent with an unweathered local urban source to the local atmosphere, consistent with observations of racemic chlordanes in the urbanized air of Chicago and Toronto [308]. However, estuary waters had nonracemic PCB 95 (EF range of 0.47 to 0.48 using Equation (4.4) on Chirasil-Dex) [194] similar to that in Hudson River sediment [160] and correlated to the Hudson River's water discharge (Figure 4.17). Using the source apportionment model (Equation (4.8)), 85% of PCB 95 and by implication mid-sized PCBs to the estuary was from the Upper Hudson River.

Little work has been done to characterize air–surface exchange of chiral semivolatile current-use pollutants. However, the observations of slightly enriched (–)- α -HBCDD and racemic β - and γ -HBCDD in Chinese urban air suggest that the atmospheric source of HBCDD may be a mixture of both local unweathered emissions and volatilization of weathered residues from soil [321]. Measurements of soil EF profiles for HBCDD have not yet been done to confirm or refute this hypothesis.

Despite these insights from chirality in soil–air source apportionment, complications remain. As previously stated, few correlations have been observed between *cis*- and *trans*-chlordanes soil EFs and soil concentrations, or labile versus persistent analyte concentration ratios [140, 147]. In Costa Rica, no correlations were found between soil and air EFs of these

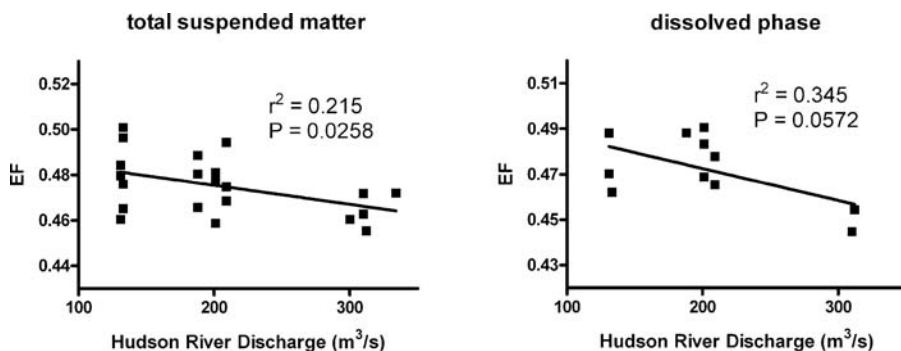

Figure 4.17 Correlation of Hudson River volumetric discharge at Waterford, New York, to enantiomer fractions (EFs) of dissolved (A) and particulate PCB 95 in the Hudson River Estuary. (Reproduced with permission from *Environmental Science and Technology*, *Chiral Source Apportionment of Polychlorinated Biphenyls to the Hudson River Estuary Atmosphere and Food Web*, by Brian J. Asher, Charles S. Wong and Lisa A. Rodenburg, **41**(17), 6163–6169. Copyright (2007) American Chemical Society)

two chlordanes [147]. Intrinsic site-to-site variability in EFs is also an issue, as site inhomogeneity in EFs can confound the use of chirality for source apportionment [180]. The lack of clear patterns in enantiomer composition was also observed in Indiana air for *cis*- and *trans*-chlordane, suggesting that source apportionment was not possible there [322]. Caution is thus urged in source apportionment studies to ensure that intrinsic sample variability is characterized [180].

4.6.2 Air–Water Exchange

Chirality has also been used along similar lines as a tracer to understand the dynamics of chemical air–water exchange. Nearly all of the work to date has focused on α -HCH. Enantiomer signatures of α -HCH in Arctic Ocean waters and marine boundary-layer air were nonracemic and similar to each other [118, 119]. Measured water/air fugacity fractions (Equation (6.1)) were also greater than 0.5 in most parts of the Arctic from the early 1990s to today [117–119, 122], except over the Greenland Sea [118, 119], which was closer to air–water equilibrium. The similar enantiomer residues in air and water, in conjunction with the fugacity calculations, indicated that the Arctic was a source of α -HCH to the air in the early 1990s and that Arctic air was not receiving new (e.g. unweathered racemic) α -HCH inputs from elsewhere. This net volatilization is a reversal of the net deposition of α -HCH from the late 1980s [323], suggesting that decreases in atmospheric loadings after the 1980s resulted in a change in the direction of air–water exchange. The exceptions were in air over the polar cap [118] and over Resolute Bay [117] in the early 1990s, which had racemic α -HCH. In the former case, air–water exchange was cut off by the presence of surface ice [118] (Figure 4.18). At Resolute Bay, the nonracemic water residues in the early 1990s may be due to the fugacity fraction being only significantly but slightly in favor of net

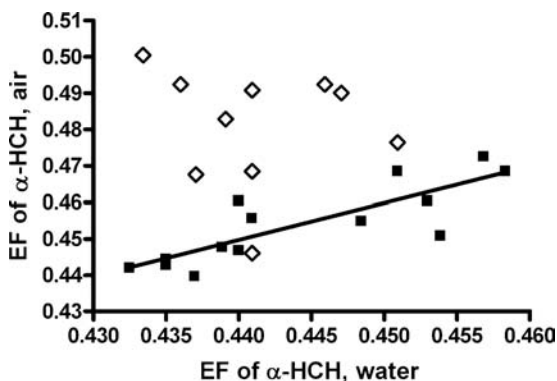

Figure 4.18 Enantiomer fractions (EFs) of α -HCH in air above Resolute Bay, Nunavut, Canada, showing a correlation ($r^2 = 0.68$) when >90% open water is present (squares) but no correlation when 0–50% open water is present (diamonds). (Reproduced with permission from *Environmental Science and Technology, Hexachlorohexanes (HCHs) in the Canadian Archipelago. 2. Air–Water Gas Exchange of α - and γ -HCH*, by Liisa M. Jantunen, Paul A. Helm, Henrik Kylin and Terry F. Bidleman, **42**(2), 465–470. Copyright (2008) American Chemical Society)

volatilization [117], and were later shown to be affected by the amount of ice cover present within several kilometers of the sampling site [324].

Similar approaches have been used to assess air–water exchange of chiral POPs, mostly α -HCH, in other water bodies. Warmer temperatures during summer and early fall resulted in net volatilization of nonracemic α -HCH in the North Sea, which was reflected not only in the overlying atmosphere but also in precipitation that had equilibrated with the nonracemic α -HCH vapor [325]. Using fugacity calculations and source apportionment similar to Equation (4.7), up to 60% of the α -HCH above Lake Ontario was attributed to volatilization from the lake, with most nonracemic signatures and volatilization occurring over the warmer summer months with greater microbial degradation activity [128]. Varying EFs and fugacity ratios of α -HCH, *cis*- and *trans*-chlordane, and heptachlor epoxide was observed in the other Laurentian Great Lakes [326]. In the south Baltic Sea, concentrations of α -HCH were quite variable, resulting in near air–water equilibrium based on fugacity [327]. However, EF-based source apportionment (Equation (4.8)) indicated that about 60% of the α -HCH in the boundary-layer air above the sea arose from volatilization during the summer, while significantly less (0–35%) volatilized during wintertime [327]. Thus, chirality was suggested as an integral and complementary component of environmental monitoring [327]. In contrast to northern waters, fugacity ratios in the south Atlantic Ocean indicated a net deposition of α -HCH; however, EFs in boundary-layer air still resembled that of nonracemic surface waters, indicating that the air–water exchange was dynamic and in both directions [131].

4.7 Caveats in Using Chirality to Probe Biologically Mediated Environmental Processes

While chirality is a powerful tool for detecting and understanding biochemical weathering processes in the environment, some caveats and precautions should be kept in mind. First, a compound must be asymmetric in order for chirality to be used. Thus, while extrapolations to structurally similar compounds may be plausible [194], such interpretations must be made cautiously in light of the variability in enantiomer behavior of even structurally similar chemicals. An example of such variability is the observation of enantioselective degradation of PCB 136 by rainbow trout, while structurally similar PCB 95 was not degraded [227, 232].

In addition, although most abiotic processes are nonenantioselective, not all are indeed the case. Nucleophilic S_N2 -substitution reactions at a chiral center will result in chiral inversion to the antipodal enantiomer. While such processes are often biologically mediated, as for the nonsteroidal anti-inflammatory drugs [328], they can also be abiotic. Appropriate sterile controls should be used for experiments with such compounds, as was done in the demonstration of microbial chiral inversion of ibuprofen in Swiss lake water [329]. Photolysis of α -HCH [114], β -PCCH [114], and chlordane compounds [116] was demonstrated not to be enantioselective, as expected for an abiotic process. However, this may not be the case for some pyrethroids, known to isomerize photolytically.

Caution must be exercised when analyzing some pyrethroids, given possible isomerization of pyrethroids with cyano substituents at the asymmetric α -carbon atom, such as cypermethrin and cyfluthrin. Isomerization may occur in the presence of heat, polar solvents, or light. About 9% interconversion of these two compounds was observed at

260 °C, but was negligible at 180 °C or when on-column GC injection was used [96]. Cypermethrin [96] and cyfluthrin [96, 330] also isomerized slowly (half-life ca. 160 days) at the asymmetric α -carbon atom in sterile water, as does deltamethrin, which also has a cyano substituent at the asymmetric α -carbon atom in polar solvents [331, 332]. Cypermethrin isomerized rapidly in isopropanol (half-life of 3–7 days) and methanol (half-life of 2–3 days), as well as in organic solvent–water mixtures depending on water content and temperature [333]. Photolytic epimerization was observed for deltamethrin [331, 334] and for cyhalothrin, another cyano-bearing pyrethroid [335]. No isomerization by any means was observed for bifenthrin [96] and permethrin [96, 333], both of which lack cyano substituents. Thus, caution should be applied to cyano-bearing pyrethroids to avoid exposure to light and use of incompatible solvents (e.g. HPLC mobile phases), and in interpretation of enantiomer composition from environmental data to account for abiotic isomerization.

Caution should also be taken to ensure that measurement artifacts do not result in erroneous enantiomer compositions, as demonstrated by the case of HBCDD. The enantiomers of HBCDD isomerize at temperatures above 160 °C, and can do so even as low as 100 °C [54]. Consequently, they cannot be measured by GC, and care must be taken during extraction to ensure that isomerization does not occur during, for example, overnight Soxhlet extractions. Isomer-specific HBCDD analyses require HPLC/MS/MS [336, 337], which have focused on the three major diastereomer sets. While enantiomer resolution of these three sets has been demonstrated, by enantioselective HPLC/MS/MS [58], unequal peak sizes of racemic α -HBCDD purified from various technical mixtures were observed. Enantiomers at equal concentrations should have identical responses to detectors [217]. The authors [58] attributed this artifact to differential matrix effects during electrospray ionization. This effect was subsequently attributed to electrospray-induced ion suppression of HBCDD peaks, which changed with ionization temperature [338], was more severe with stronger mobile phase (i.e. later-eluted analytes using gradient elution) and with older columns more susceptible to column material bleed [99]. This observation was consistent with findings that the HBCDD ion signal was dependent on the amount of coextracted endogenous material [337]. These artifacts can be addressed by using isotopically labeled HBCDD internal standards, correcting EFs in Lake Ontario lake trout as nonracemic as 0.18 EF units from the racemic EF of 0.5 to racemic values [99]. Matrix-induced ion signal modification is an issue for any electrospray-based analysis, particularly for environmental samples with many coextracted interferences, and can result in measurement artifacts if not properly countered. If isotopically labeled internal standards are not available, enantiomer-specific standard addition can be used to assess the extent of ion suppression by electrospray ionization, as was recently demonstrated for measurements of chiral drugs in wastewaters [339].

Artifacts in EF can also occur for peaks that are not fully resolved, as is often the case in enantiomer analysis of POPs. In this case, deconvolution of enantiomer peaks using least-squares fitting of chromatographic data to mathematical models accounting for non-ideal chromatography can provide more accurate and precise results than conventional integration techniques [340]. Of course, full chromatographic resolution of peaks is always desired, but this may not be possible or feasible.

It should also be noted that lack of enantioselectivity also does not necessarily imply lack of biological activity on the chemical of interest. While α -HCH was not enantioselective in

the upstream freshwater region of the York River estuary in Chesapeake Bay, α -HCH concentrations were lower there while bacterial activity assessed by independent means was highest at that site [130]. This observation suggests nonenantioselective biotransformation. Similarly, phytodegradation of *o,p'*-DDT was not enantioselective, probably because of the reaction with a planar, nonstereoselective heme functionality [341]. Site-to-site variability in enantiomer compositions should also be assessed [180]. Chirality is best used as a complementary tool, along with other indicators, to provide the most robust lines of evidence for biologically mediated bioprocessing of POPs and other environmental pollutants.

4.8 Conclusions

Chirality of POPs has progressed considerably from initial work in the 1980s and early 1990s to resolve enantiomers once enantioselective chromatography became available. These initial studies found nonracemic compositions of many POPs, suggesting that biochemical degradation of these POPs must be occurring. Subsequent laboratory and field experiments confirmed these suggestions, and established that chiral POPs are bioprocessed in a species- or strain-specific manner. While most enantioselective bioprocessing appears to be biotransformation, others are not, most notably blood–brain barrier transfer of α -HCH. At least some of the chemical (e.g. labile versus recalcitrant structures) and physiological (e.g. sex, age, health status) factors affecting enantiomer toxicokinetics have been identified. These results have shown that although biodegradation of POPs may be slow, these chemicals are not so persistent that they cannot degrade, as was previously thought. This use of chirality may be useful in quantifying long-term removal of POPs from the environment, as needed for virtual elimination as mandated by the Stockholm Convention. The chirality of POPs has also been exploited to gain insights into source apportionment and transport of POPs among environmental media, which also aids in understanding their environmental fate.

Despite the considerable knowledge on chirality of POPs, many questions remain unanswered. One of the biggest of these is the mechanisms by which enantioselectivity occurs in organisms. With the exception of HCH and its PCCH metabolites, little is known about the stereoselectivity of enzymatic degradation of POPs. A mechanistic understanding of how POP enantiomers and their metabolites differentially interact on a molecular basis will greatly increase our current understanding of POP toxicokinetics. Likewise, little is known about POP metabolites, particularly those that are chiral. As techniques and instrumentation improve for detecting and measuring such metabolites, so should our understanding of the behavior of degradate enantiomers. In a related vein, our knowledge of enantiomer-specific toxicity is severely lacking, although research on current-use pesticides is changing this. All of the comments made above hold for current-use POPs, for which knowledge is poorer than that for legacy POPs, in part from less established analytical techniques for measuring such enantiomers. Research directions along these lines should ultimately lead to the ability to predict the environmental fate and effects of individual enantiomers based on structure/activity relations and knowledge of the pharmacokinetics and toxicokinetics of the biota involved. This capacity would be the logical extension of existing models for classes of compounds (e.g. labile versus recalcitrant PCBs based on structure), but does not yet exist at the current time. It, and the knowledge required to support

such a framework, would be invaluable when using chirality as an integral tool to assess and mitigate deleterious effects of chiral pollutants.

Acknowledgements

The authors acknowledge the financial support of the Natural Sciences and Engineering Research Council of Canada and the Canada Research Chairs program to CSW in the preparation of this chapter.

References

1. Williams, A., Opportunities for chiral agrochemicals; *Pestic. Sci.* 1996, **46**, 3–9.
2. Kaiser, K.L.E., On the optical activity of polychlorinated biphenyls; *Environ. Pollut.* 1974, **7**, 93–101.
3. Vetter, W., Toxaphene. Theoretical aspects of the distribution of chlorinated bornanes including symmetrical aspects; *Chemosphere* 1993, **26**, 1079–1084.
4. Berger, U.; Vetter, W.; Götsch, A.; Kallenborn, R., Chromatographic enrichment and enantiomer separation of axially chiral polybrominated biphenyls in a technical mixture; *J. Chromatogr. A* 2002, **973**, 123–133.
5. von der Recke, R.; Vetter, W., Synthesis and characterization of 2,3-dibromopropyl-2,4,6-tribromophenyl ether (DPTE) and structurally related compounds evidenced in seal blubber and brain; *Environ. Sci. Technol.* 2007, **41**, 1590–1595.
6. Kania-Korwel, I.; Vyas, S.M.; Song, Y.; Lehmler, H.-J., Gas chromatographic separation of methoxylated polychlorinated biphenyl atropisomers; *J. Chromatogr. A* 2008, **1207**, 146–154.
7. Letcher, R.J.; Klasson-Wehler, E.; Bergman, A., Methyl sulfone and hydroxylated metabolites of polychlorinated biphenyls; In: *The Handbook of Environmental Chemistry*, J. Paasivirta, editor, volume 3, Springer-Verlag, 2000, p. 315–359.
8. McBlain, W.A., The levo enantiomer of *o,p'*-DDT inhibits the binding of 17 β -estradiol to the estrogen receptor; *Life Sci.* 1987, **40**, 215–221.
9. Hoekstra, P.F.; Burnison, B.K.; Neheli, T.; Muir, D.C.G., Enantiomer-specific activity of *o,p'*-DDT with the human estrogen receptor; *Toxicol. Lett.* 2001, **125**, 75–81.
10. Wang, L.; Zhou, S.; Lin, K.; Zhao, M.; Liu, W.; Gan, J., Enantioselective estrogenicity of *o,p'*-dichlorodiphenyltrichloroethane in the MCF-7 human breast carcinoma cell line; *Environ. Toxicol. Chem.* 2009, **28**, 1–8.
11. Püttmann, M.; Mannschreck, A.; Oesch, F.; Robertson, L., Chiral effects in the induction of drug-metabolizing enzymes using synthetic atropisomers of polychlorinated biphenyls (PCBs); *Biochem. Pharmacol.* 1989, **38**, 1345–1352.
12. Rodman, L.E.; Shedlofsky, S.I.; Mannschreck, A.; Püttmann, M.; Swim, A.T.; Robertson, L.W., Differential potency of atropisomers of polychlorinated biphenyls on cytochrome P450 induction and uroporphyrin accumulation in the chick embryo hepatocyte culture; *Biochem. Pharmacol.* 1991, **41**, 915–922.
13. Pessah, I.N.; Lehmler, H.-J.; Robertson, L.W.; Perez, C.F.; Cabrales, E.; Bose, D.D.; Fang, W., Enantiomeric specificity of (–)-2,2',3,3',6,6'-hexachlorobiphenyl toward ryanodine receptor types 1 and 2; *Chem. Res. Toxicol.* 2009, **22**, 201–207.
14. Lehmler, H.-J.; Robertson, L.W.; Garrison, A.W.; Kodavanti, P.R.S., Effects of PCB 84 enantiomers on [³H]-phorbol ester binding in rat cerebellar granule cells and ⁴⁵Ca²⁺-uptake in rat cerebellum; *Toxicol. Lett.* 2005, **156**, 391–400.
15. Hühnerfuss, H., Chromatographic enantiomer separation of chiral xenobiotics and their metabolites: A versatile tool for process studies in marine and terrestrial ecosystems; *Chemosphere* 2000, **40**, 913–919.

16. Miyazaki, A.; Hotta, T.; Marumo, S.; Sakai, M., Synthesis absolute stereochemistry, and biological activity of optically active cyclodiene insecticides; *J. Agric. Food Chem.* 1978, **26**, 975–977.
17. Miyazaki, A.; Sakai, M.; Marumo, S., Synthesis and biological activity of optically active heptachlor, 2-chloroheptachlor, and 3-chloroheptachlor; *J. Agric. Food Chem.* 1980, **28**, 1310–1311.
18. Wang, L.; Liu, W.; Yang, C.; Pan, Z.; Gan, J.; Xu, C.; Zhao, M.; Schlenk, D., Enantioselectivity in estrogenic potential and uptake of bifenthrin; *Environ. Sci. Technol.* 2007, **41**, 6124–6128.
19. Liu, W.; Gan, J.; Lee, S.; Werner, I., Isomer selectivity in aquatic toxicology and biodegradation of bifenthrin and permethrin; *Environ. Toxicol. Chem.* 2005, **24**, 1861–1866.
20. Liu, W.; Gan, J.; Schlenk, D.; Jury, W.A., Enantioselectivity in environmental safety of current chiral insecticides; *Proc. Nat. Acad. Sci. USA* 2005, **102**, 701–706.
21. Jin, Y.; Wang, W.; Xu, C.; Fu, Z.; Liu, W., Induction of hepatic estrogen-responsive gene transcription by permethrin enantiomers in male adult zebrafish; *Aquat. Toxicol.* 2008, **88**, 146–152.
22. Cremllyn, R.J.W., *Agrochemicals: Preparation and Mode of Action*; John Wiley and Sons; New York, 1991.
23. Pest Management Regulatory Agency, Chemistry Requirements for the Registration of a Manufacturing Concentrate or an End-Use Product Formulated from Registered Technical Grade of Active Ingredients or Integrated System Products; Regulatory Directive Dir98-03, Health Canada, Ottawa ON, 1998.
24. Pest Management Regulatory Agency, Chemistry Requirements for the Registration of a Technical Grade of Active Ingredient or an Integrated System Product; Regulatory Directive Dir98-04, Health Canada, Ottawa ON, 1998.
25. USEPA, Pesticides; Request for Comment on Pesticide Registration Proposal for Isomeric Active Ingredients; *Fed. Reg.* 1999, **64**(81), 22863–22865, 28 April 1999.
26. USEPA, Equivalency of Pesticides Metolachlor and S-metolachlor With Request to Ground Water Contamination; Notice of Availability and Request for Comment; *Fed. Reg.* 2000, **65** (36), 8925–8927, 23 February 2000.
27. USEPA, Response to Public Comments on the Preliminary Risk Assessment for the Organophosphate Naled; Docket #34136, U.S. Environmental Protection Agency, Washington DC, 1999.
28. Magrans, J.O.; Alonso-Prados, J.; García-Baudín, J.M., Importance of considering pesticide stereoisomerism—Proposal of a scheme to apply Directive 91/414/EEC framework to pesticide active substances manufactured as isomeric mixtures; *Chemosphere* 2002, **49**, 461–469.
29. Wong, C.S., Environmental fate processes and biochemical transformations of chiral emerging organic pollutants; *Anal. Bioanal. Chem.* 2006, **386**, 544–558.
30. Pérez, S.; Barceló, D., Applications of LC-MS to quantitation and evaluation of the environmental fate of chiral drugs and their metabolites; *Trends. Anal. Chem.* 2008, **27**, 836–846.
31. Buser, H.-R.; Müller, M.D., Isomer-selective and enantiomerselective determination of DDT and related compounds using chiral high-resolution gas chromatography/mass spectrometry and chiral high-performance liquid chromatography; *Anal. Chem.* 1995, **67**, 2691–2698.
32. Willett, K.L.; Ulrich, E.M.; Hites, R.A., Differential toxicity and environmental fates of hexachlorocyclohexane isomers; *Environ. Sci. Technol.* 1998, **32**, 2197–2207.
33. Li, Y.F., Global technical hexachlorocyclohexane usage and its contamination consequences in the environment: From 1948 to 1997; *Sci. Total Environ.* 1999, **232**, 121–158.
34. Dearth, M.A.; Hites, R.A., Complete analysis of technical chlordane using negative ionization mass spectrometry; *Environ. Sci. Technol.* 1991, **25**, 245–254.
35. Bidleman, T.F.; Jantunen, L.M.M.; Wiberg, K.; Harner, T.; Brice, K.A.; Su, K.; Falconer, R.L.; Leone, A.D.; Aigner, E.J.; Parkhursts, W.J., Soil as a source of atmospheric heptachlor epoxide; *Environ. Sci. Technol.* 1998, **32**, 1546–1548.
36. Andrews, P.; Vetter, W., A systematic nomenclature system for toxaphene congeners. Part 1: Chlorinated bornanes; *Chemosphere* 1995, **31**, 3879–3886.
37. Schurig, V.; Reich, S., Determination of the rotational barriers of atropisomeric polychlorinated biphenyls (PCBs) by a novel stopped-flow multidimensional gas chromatographic technique; *Chirality* 1998, **10**, 316–320.

38. Harju, M.T.; Haglund, P., Determination of the rotational energy barriers of atropisomeric polychlorinated biphenyls; *Fresenius J. Anal. Chem.* 1999, **364**, 219–223.
39. Haglund, P., Enantioselective separation of polychlorinated biphenyl atropisomers using chiral high-performance liquid chromatography; *J. Chromatogr. A* 1996, **724**, 219–228.
40. Ballschmiter, K.; Zell, M., Analysis of polychlorinated biphenyls (PCB) by glass capillary gas chromatography; *Fresenius Z. Anal. Chem.* 1980, **302**, 20–31.
41. Bakke, J.E.; Bergman, A.L.; Larsen, G.L., Metabolism of 2,4',5-trichlorobiphenyl by the mercapturic acid pathway; *Science* 1982, **217**, 645–647.
42. Nezel, T.; Müller-Plathe, F.; Müller, M.D.; Buser, H.-R., Theoretical considerations about chiral PCBs and their methylthio and methylsulfonyl metabolites being possibly present as stable enantiomers; *Chemosphere* 1997, **35**, 1895–1906.
43. Maervoet, J.; Covaci, A.; Schepens, P.; Sandau, C.D.; Letcher, R.J., A reassessment of the nomenclature of polychlorinated biphenyl (PCB) metabolites; *Environ. Health Perspect.* 2004, **112**, 291–294.
44. Hill, I.R., Aquatic organisms and pyrethroids; *Pestic. Sci.* 1989, **27**, 429–465.
45. Maund, S.J.; Hamer, M.J.; Lane, M.C.G.; Farrelly, E.; Rapley, J.H.; Goggin, U.M.; Gentle, W.E., Partitioning, bioavailability, and toxicity of the pyrethroid insecticide cypermethrin in sediments; *Environ. Toxicol. Chem.* 2002, **21**, 9–15.
46. Naumann, K., *Synthetic Pyrethroid Insecticides: Structures and Properties*; Springer-Verlag: Berlin, 1990.
47. Heberer, T., Occurrence, fate, and assessment of polycyclic musk residues in the aquatic environment of urban areas: A review; *Acta Hydrochim. Hydrobiol.* 2002, **30**, 227–243.
48. Reiner, J.L.; Kannan, K., A survey of polycyclic musks in selected household commodities from the United States; *Chemosphere* 2006, **62**, 867–873.
49. Peck, A.M.; Linebaugh, E.K.; Hornbuckle, K.C., Synthetic musk fragrances in Lake Erie and Lake Ontario sediment cores; *Environ. Sci. Technol.* 2006, **40**, 5629–5635.
50. Becher, G., The stereochemistry of 1,2,5,6,9,10-hexabromocyclododecane and its graphic representation; *Chemosphere* 2005, **58**, 989–991.
51. Heeb, N.V.; Schweizer, W.B.; Kohler, M.; Gerecke, A.C., Structure elucidation of hexabromocyclododecanes: A class of compounds with a complex stereochemistry; *Chemosphere* 2005, **61**, 65–73.
52. Peled, M.; Scharia, R.; Sondack, D., Thermal rearrangement of hexabromocyclododecane (HBCD); In: *Advances in Organobromine Chemistry II*, J.R. Desmurs; B. Gérard; M.J. Goldstein, editors Elsevier; Amsterdam, 1995, p. 92–99.
53. Arsenault, G.; Konstantinov, A.; Marvin, C.H.; MacInnis, G.; McAlees, A.; McCrindle, R.; Riddell, N.; Tomy, G.T.; Yeo, B., Synthesis of the two minor isomers, δ - and ϵ -1,2,5,6,9,10-hexabromocyclododecane, present in commercial hexabromocyclododecane; *Chemosphere* 2007, **68**, 887–892.
54. Heeb, N.V.; Schweizer, W.B.; Mattrel, P.; Haag, R.; Gerecke, A.C.; Schmid, P.; Zennegg, M.; Vonmont, H., Regio- and stereoselective isomerization of hexabromocyclododecanes (HBCDs): Kinetics and mechanism of γ - to α -HBCD isomerization; *Chemosphere* 2008, **73**, 1201–1210.
55. Köppen, R.; Becker, R.; Jung, C.; Nehls, I., On the thermally induced isomerisation of hexabromocyclododecane stereoisomers; *Chemosphere* 2008, **71**, 656–662.
56. Heeb, N.V.; Schweizer, W.B.; Mattrel, P.; Haag, R.; Kohler, M., Crystal structure analysis of enantiomerically pure (+) and (–) β -hexabromocyclododecanes; *Chemosphere* 2007, **66**, 1590–1594.
57. Koeppen, R.; Becker, R.; Emmerling, F.; Jung, C.; Nehls, I., Enantioselective preparative HPLC separation of the HBCD-stereoisomers from the technical product and their absolute structure elucidation using X-ray crystallography; *Chirality* 2007, **19**, 214–222.
58. Janák, K.; Covaci, A.; Voorspoels, S.; Becher, G., Hexabromocyclododecane in marine species from the Western Scheldt Estuary: Diastereoisomer- and enantiomer-specific accumulation; *Environ. Sci. Technol.* 2005, **39**, 1987–1994.
59. Zegers, B.N.; Mets, A.; van Bommel, R.; Minkenberg, C.; Hamers, T.; Kamstra, J.H.; Pierce, G.J.; Boon, J.P., Levels of hexabromocyclododecane in harbor porpoises and common dolphins

- from Western European seas, with evidence for stereoisomer-specific biotransformation by cytochrome P450; *Environ. Sci. Technol.* 2005, **39**, 2095–2100.
60. Tomy, G.T.; Budakowski, W.; Halldorson, T.; Whittle, D.M.; Keir, M.J.; Marvin, C.; MacInnis, G.; Alae, M., Biomagnification of α - and γ -hexabromocyclododecane isomers in a Lake Ontario food web; *Environ. Sci. Technol.* 2004, **38**, 2298–2303.
 61. Law, K.; Halldorson, T.; Danell, R.; Stern, G.; Gewurtz, S.; Alae, M.; Marvin, C.; Whittle, M.; Tomy, G., Bioaccumulation and trophic transfer of some brominated flame retardants in a Lake Winnipeg (Canada) food web; *Environ. Toxicol. Chem.* 2006, **25**, 2177–2186.
 62. Law, R.J.; Kohler, M.; Heeb, N.V.; Gerecke, A.C.; Schmid, P.; Voorspoels, S.; Covaci, A.; Becher, G.; Janák, K.; Thomsen, C., Hexabromocyclododecane challenges scientists and regulators; *Environ. Sci. Technol.* 2005, **39**, 281A–287A.
 63. Law, K.; Palace, V.P.; Halldorson, T.; Danell, R.; Wautier, K.; Evans, B.; Alae, M.; Marvin, C.; Tomy, G.T., Dietary accumulation of hexabromocyclododecane diastereoisomers in juvenile rainbow trout (*Onorhynchus mykiss*) I: Bioaccumulation parameters and evidence of bioisomerization; *Environ. Toxicol. Chem.* 2006, **25**, 1757–1761.
 64. Hunziker, R.W.; Gonsior, S.; MacGregor, J.A.; Desjardins, D.; Ariano, J.; Friederich, U., Fate and effect of hexabromocyclododecane in the environment; *Organohalogen Compounds* 2004, **66**, 2275–2280.
 65. Mannschreck, A.; Pustet, N.; Robertson, L.W.; Oesch, F.; Püttmann, M., Enantiomers of polychlorinated biphenyls semipreparative enrichment by liquid chromatography; *Liebigs Ann. Chem.* 1985, (10), 2101–2103.
 66. Hühnerfuss, H.; Pfaffenberger, B.; Gehrcke, B.; Karbe, L.; König, W.A.; Landgraff, O., Stereochemical effects of PCBs in the marine environment: Seasonal variation of coplanar and atropisomeric PCBs in blue mussels (*Mytilus edulis* L.) of the German Bight; *Mar. Poll. Bull.* 1995, **30**, 332–340.
 67. Vetter, W.; Schurig, V., Enantioselective determination of chiral organochlorine compounds in biota by gas chromatography on modified cyclodextrins; *J. Chromatogr. A* 1997, **774**, 143–175.
 68. Glausch, A.; Nicholson, G.J.; Fluck, M.; Schurig, V., Separation of the enantiomers of stable atropisomeric polychlorinated biphenyls (PCBs) by multidimensional gas chromatography on Chirasil-Dex; *J. High Resol. Chromatogr.* 1994, **17**, 347–349.
 69. Glausch, A.; Hahn, J.; Schurig, V., Enantioselective determination of chiral 2,2',3,3', 4,6'-hexachlorobiphenyl (PCB 132) in human milk samples by multidimensional gas chromatography/electron capture detection and by mass spectrometry; *Chemosphere* 1995, **30**, 2079–2085.
 70. Benická, E.; Novakovsky, R.; Hrouzek, J.; Krupčík, J., Multidimensional gas chromatographic separation of selected PCB atropisomers in technical formulations and sediments; *J. High Resol. Chromatogr.* 1996, **19**, 95–98.
 71. Glausch, A.; Blanch, G.P.; Schurig, V., Enantioselective analysis of chiral polychlorinated biphenyls in sediment samples by multidimensional gas chromatography–electron-capture detection after steam distillation–solvent extraction and sulfur removal; *J. Chromatogr. A* 1996, **723**, 399–404.
 72. Blanch, G.P.; Glausch, A.; Schurig, V., Determination of the enantiomeric ratios of chiral PCB 95 and 149 in human milk samples by multidimensional gas chromatography with ECD and MS(SIM) detection; *Eur. Food Res. Technol.* 1999, **209**, 294–296.
 73. Bordajandi, L.R.; Korytár, P.; de Boer, J.; Gonzalez, M.J., Enantiomeric separation of chiral polychlorinated biphenyls on β -cyclodextrin capillary columns by means of heart-cut multidimensional gas chromatography and comprehensive two-dimensional gas chromatography. Application to food samples; *J. Sep. Sci.* 2005, **28**, 163–171.
 74. Bordajandi, L.R.; Ramos, L.; González, M.J., Chiral comprehensive two-dimensional gas chromatography with electron-capture detection applied to the analysis of chiral polychlorinated biphenyls in food samples; *J. Chromatogr. A* **1078**, 2005, 128–135.
 75. Bucheli, T.D.; Brändli, R.C., Two-dimensional gas chromatography coupled to triple quadrupole mass spectrometry for the unambiguous determination of atropisomeric polychlorinated biphenyls in environmental samples; *J. Chromatogr. A* 2006, **1110**, 156–164.

76. Bordajandi, L.R.; Abad, E.; González, M.J., Occurrence of PCBs, PCDD/Fs, PBDEs and DDTs in Spanish breast milk: Enantiomeric fraction of chiral PCBs; *Chemosphere* 2008, **70**, 567–575.
77. Vetter, W.; Luckas, B., Theoretical aspects of polychlorinated bornanes and composition of toxaphene in technical mixtures and environmental samples; *Sci. Total Environ.* 1995, **160/161**, 505–510.
78. Hamed, S.; Leupold, G.; Ismail, A.; Parlar, H., Enantioselective determination of chiral toxaphene congeners in laying hens and eggs using multidimensional high-resolution gas chromatography; *J. Agric. Food Chem.* 2005, **53**, 7156–7164.
79. Shellie, R.; Marriott, P.J., Comprehensive two-dimensional gas chromatography with fast enantioseparation; *Anal. Chem.* 2002, **74**, 5426–5430.
80. Harju, M.; Haglund, P., Comprehensive two-dimensional gas chromatography (GC × GC) of atropisomeric PCBs, combining a narrow bore β -cyclodextrin column and a liquid crystal column; *J. Microcol. Sep.* 2001, **13**, 300–305.
81. Harju, M.; Bergman, A.; Olsson, M.; Roos, A.; Haglund, P., Determination of atropisomeric and planar polychlorinated biphenyls, their enantiomeric fractions and tissue distribution in grey seals using comprehensive 2D gas chromatography; *J. Chromatogr. A* 2003, **1019**, 127–142.
82. Bordajandi, L.R.; Ramos, L.; González, M.J., Determination of toxaphene enantiomers by comprehensive two-dimensional gas chromatography with electron-capture detection; *J. Chromatogr. A* 2006, **1125**, 220–228.
83. Faraoni, M.; Messina, A.; Polcaro, C.M.; Aturki, Z.; Sinibaldi, M., Chiral separation of pesticides by coupled-column liquid chromatography application to the stereoselective degradation of fenvalerate in soil; *J. Liquid Chromatogr. Rel. Technol.* 2004, **27**, 995–1012.
84. Wang, Q.; Qiu, J.; Zhu, W.; Jia, G.; Li, J.; Bi, C.; Zhou, Z., Stereoselective degradation kinetics of theta-cypermethrin in rats; *Environ. Sci. Technol.* 2006, **40**, 721–726.
85. Reich, S.; Jimenez, B.; Marsili, L.; Hernández, L.M.; Schurig, V.; González, M.J., Congener specific determination and enantiomeric ratios of chiral polychlorinated biphenyls in striped dolphins (*Stenella coeruleoalba*) from the Mediterranean Sea; *Environ. Sci. Technol.* 1999, **33**, 1787–1793.
86. Jiménez, O.; Jiménez, B.; Gonzalez, M.J., Isomer-specific polychlorinated biphenyl determination in cetaceans from the Mediterranean Sea: Enantioselective occurrence of chiral polychlorinated biphenyl congeners; *Environ. Toxicol. Chem.* 2000, **19**, 2653–2660.
87. Serrano, R.; Fernández, M.; Rabanal, R.; Hernández, M.; Gonzalez, M.J., Congener-specific determination of polychlorinated biphenyls in shark and grouper livers from the northwest African Atlantic Ocean; *Arch. Environ. Contam. Toxicol.* 2000, **38**, 217–224.
88. Champion, Jr. W.L.; Lee, J.; Garrison, A.W.; DiMarco, J.C.; Matabe, A.; Prickett, K.B., Liquid chromatographic separation of the enantiomers of *trans*-chlordane, *cis*-chlordane, heptachlor, heptachlor epoxide and α -hexachlorocyclohexane with application to small-scale preparative separation; *J. Chromatogr. A* **1024**, 2004, 55–62.
89. Müller, M.D.; Buser, H.-R., Identification of the (+)- and (–)-enantiomers of chiral chlordane compounds using chiral high-performance liquid chromatography/chiroptical detection and chiral high-resolution gas chromatography/mass spectrometry; *Anal. Chem.* 1994, **66**, 2155–2162.
90. Müller, M.D.; Buser, H.-R., Conversion reactions of various phenoxyalkanoic acid herbicides in soil. 1. Enantiomerization and enantioselective degradation of the chiral 2-phenoxypropionic acid herbicides; *Environ. Sci. Technol.* 1997, **31**, 1953–1959.
91. Haglund, P.; Wiberg, K., Determination of the gas chromatographic elution sequences of the (+)- and (–)-enantiomers of stable atropisomeric PCBs on Chirasil-Dex; *J. High Resol. Chromatogr.* 1996, **19**, 373–376.
92. Liu, W.; Gan, J.J., Separation and analysis of diastereomers and enantiomers of cypermethrin and cyfluthrin by gas chromatography; *J. Agric. Food Chem.* 2004, **52**, 755–761.
93. Heeb, N.V.; Schweizer, W.B.; Mattrel, P.; Haag, R.; Gerecke, A.C.; Kohler, M.; Schmid, P.; Zennegg, M.; Wolfensberger, M., Solid-state conformations and absolute configurations of (+) and (–) α -, β -, and γ -hexabromocyclododecanes (HBCDs); *Chemosphere* 2007, **68**, 940–950.
94. Döbler, J.; Peters, N.; Larsson, C.; Bergman, A.; Geidel, E.; Hühnerfuss, H., The absolute structures of separated PCB-methylsulfone enantiomers determined by vibrational circular dichroism and quantum mechanical calculations; *J. Molec. Struct. (Theochem)* 2002, **586**, 159–166.

95. Pham-Tuan, H.; Larsson, C.; Hoffmann, F.; Bergman, Å.; Fröba, M.; Hühnerfuss, H., Enantioselective semipreparative HPLC separation of PCB metabolites and their absolute structure elucidation using electronic and vibrational circular dichroism; *Chirality* 2005, **17**, 266–280.
96. Liu, W.; Qin, S.; Gan, J., Chiral stability of synthetic pyrethroid insecticides; *J. Agric. Food Chem.* 2005, **53**, 3814–3820.
97. Liu, W.; Gan, J.J.; Qin, S., Separation and aquatic toxicity of enantiomers of synthetic pyrethroid insecticides; *Chirality* 2005, **17**, S127–S133.
98. Dodder, N.G.; Peck, A.M.; Kucklick, J.R.; Sander, L.C., Analysis of hexabromocyclododecane diastereomers and enantiomers by liquid chromatography/tandem mass spectrometry: Chromatographic selectivity and ionization matrix effects; *J. Chromatogr. A* 2006, **1135**, 36–42.
99. Marvin, C.H.; MacInnis, G.; Alae, M.; Arsenaault, G.; Tomy, G.T., Factors influencing enantiomeric fractions of hexabromocyclododecane measured using liquid chromatography/tandem mass spectrometry; *Rapid Commun. Mass Spectrom.* 2007, **21**, 1925–1930.
100. Ali, I.; Gupta, V.K.; Aboul-Enein, H.Y., Chiral resolution of racemic environmental pollutants by capillary electrophoresis; *Crit. Rev. Anal. Chem.* 2008, **38**, 132–146.
101. Kallenborn, R.; Hühnerfuss, H., *Chiral Environmental Pollutants: Trace Analysis and Ecotoxicology*; Springer-Verlag: Heidelberg, Germany, 2001.
102. Vetter, W., Enantioselective fate of chiral chlorinated hydrocarbons and their metabolites in environmental samples; *Food Rev. Int.* 2001, **17**, 113–182.
103. Ali, I.; Gupta, V.K.; Aboul-Enein, H.Y., Chiral resolution of some environmental pollutants by capillary electrophoresis; *Electrophoresis* 2003, **24**, 1360–1374.
104. Wong, C.S.; Chiral polychlorinated biphenyls and their metabolites; In: *PCBs: Human and Environmental Disposition and Toxicity*, L.G. Hanson; L.W. Robertson, editors, University of Illinois Press; Urbana IL, 2008, p. 30–50.
105. Wong, C.S.; Hoekstra, P.F.; Karlsson, H.; Backus, S.M.; Mabury, S.A.; Muir, D.C.G., Enantiomer fractions of chiral organochlorine pesticides and polychlorinated biphenyls in Standard and Certified Reference Materials; *Chemosphere* 2002, **49**, 1339–1347.
106. Morrissey, J.A.; Bleackley, D.S.; Warner, N.A.; Wong, C.S., Enantiomer fractions of polychlorinated biphenyls in three selected Standard Reference Materials; *Chemosphere* 2006, **66**, 326–331.
107. Harner, T.; Wiberg, K.; Norstrom, R., Enantiomer fractions are preferred to enantiomer ratios for describing chiral signatures in environmental analysis; *Environ. Sci. Technol.* 2000, **34**, 218–220.
108. de Geus, H.-J.; Wester, P.G.; de Boer, J.; Brinkman, U.A.T., Enantiomer fractions instead of enantiomer ratios; *Chemosphere* 2000, **41**, 725–727.
109. Ulrich, E.M.; Helsel, D.R.; Foreman, W.T., Complications with using ratios for environmental data: Comparing enantiomeric ratios (ERs) and enantiomer fractions (EFs); *Chemosphere* 2003, **53**, 531–538.
110. Faller, J.; Hühnerfuss, H.; König, W.A.; Krebber, R.; Ludwig, P., Do marine bacteria degrade α -hexachlorocyclohexane stereoselectively?; *Environ. Sci. Technol.* 1991, **25**, 676–678.
111. Pfaffenberger, B.; Hühnerfuss, H.; Kallenborn, R.; Köhler-Günther, A.; König, W.A.; Krüner, G., Chromatographic separation of the enantiomers of marine pollutants. Part 6: Comparison of the enantioselective degradation of α -hexachlorocyclohexane in marine biota and water; *Chemosphere* 1992, **25**, 719–725.
112. Müller, M.D.; Schlabach, M.; Oehme, M., Fast and precise determination of α -hexachlorocyclohexane enantiomers in environmental samples using chiral high-resolution gas chromatography; *Environ. Sci. Technol.* 1992, **26**, 566–569.
113. Ludwig, P.; Hühnerfuss, H.; König, W.A.; Gunkel, W., Chromatographic separation of the enantiomers of marine pollutants. Part 3: Enantioselective degradation of α -hexachlorocyclohexane and γ -hexachlorocyclohexane by marine microorganisms; *Mar. Chem.* 1992, **38**, 13–23.
114. Hühnerfuss, H.; Faller, J.; König, W.A.; Ludwig, P., Gas chromatographic separation of the enantiomers of marine pollutants. 4. Fate of hexachlorocyclohexane isomers in the Baltic and North Sea; *Environ. Sci. Technol.* 1992, **26**, 2127–2133.
115. Trantírek, L.; Hynková, K.; Nagata, Y.; Murzin, A.; Ansorgová, A.; Sklenář, V.; Damborský, J., Reaction mechanism and stereochemistry of γ -hexachlorocyclohexane dehydrochlorinase LinA; *J. Biol. Chem.* 2001, **276**, 7734–7740.

116. Buser, H.-R.; Müller, M.D., Enantioselective determination of chlordane components, metabolites, and photoconversion products in environmental samples using chiral high-resolution gas chromatography and mass spectrometry; *Environ. Sci. Technol.* 1993, **27**, 1211–1220.
117. Falconer, R.L.; Bidleman, T.F.; Gregor, D.J., Air-gas exchange and evidence for metabolism of hexachlorocyclohexanes in Resolute Bay, N.W.T.; *Sci. Total Environ.* 1995, **160/161**, 65–74.
118. Jantunen, L.M.; Bidleman, T., Air-water gas exchange of hexachlorocyclohexanes (HCHs) and the enantiomers of α -HCH in arctic regions; *J. Geophys. Res.* 1996, **101** (D22), 28837–28846.
119. Jantunen, L.M.; Bidleman, T., Correction to “Air-water gas exchange of hexachlorocyclohexanes (HCHs) and the enantiomers of α -HCH in arctic regions”; *J. Geophys. Res.* 1997, **102** (D15), 19279–19282.
120. Bidleman, T.F.; Jantunen, L.M.; Harner, T.; Wiberg, K.; Wideman, J.L.; Brice, K.; Su, K.; Falconer, R.L.; Aigner, E.J.; Leone, A.D.; Ridal, J.J.; Kerman, B.; Finizio, A.; Alegria, H.; Parkhurst, W.J.; Szeto, S.Y., Chiral pesticides as tracers of air-water exchange; *Environ. Pollut.* 1998, **102**, 43–49.
121. Jantunen, L.M.M.; Bidleman, T.F., Organochlorine pesticides and enantiomers of chiral pesticides in Arctic Ocean water; *Arch. Environ. Contam. Toxicol.* 1998, **35**, 218–228.
122. Ding, X.; Wang, X.-M.; Xie, Z.-Q.; Xiang, C.-H.; Mai, B.-X.; Sun, L.-G.; Zheng, M.; Sheng, G.-Y.; Fu, J.-M., Atmospheric hexachlorocyclohexanes in the North Pacific Ocean and the adjacent Arctic region: Spatial patterns, chiral signatures, and sea-air exchanges; *Environ. Sci. Technol.* 2007, **41**, 5204–5209.
123. Bidleman, T.F.; Kylin, H.; Jantunen, L.M.; Helm, P.A.; MacDonald, R.W., Hexachlorocyclohexanes in the Canadian Archipelago. 1. Spatial distribution and pathways of α -, β -, and γ -HCHs in surface water; *Environ. Sci. Technol.* 2007, **41**, 2688–2695.
124. Helm, P.A.; Diamond, M.L.; Semkin, R.; Bidleman, T.F., Degradation as a loss mechanism in the fate of α -hexachlorocyclohexane in Arctic watersheds; *Environ. Sci. Technol.* 2000, **34**, 812–818.
125. Falconer, R.L.; Bidleman, T.F.; Gregor, D.J.; Semkin, R.; Teixeira, C., Enantioselective breakdown of α -hexachlorocyclohexane in a small Arctic lake and its watershed; *Environ. Sci. Technol.* 1995, **29**, 1297–1302.
126. Law, S.A.; Diamond, M.L.; Helm, P.A.; Jantunen, L.M.; Alaee, M., Factors affecting the occurrence and enantiomeric degradation of hexachlorocyclohexane isomers in northern and temperate aquatic systems; *Environ. Toxicol. Chem.* 2001, **20**, 2690–2698.
127. Harner, T.; Kylin, H.; Bidleman, T.F.; Strachan, W.M.J., Removal of α - and γ -hexachlorocyclohexane and enantiomers of α -hexachlorocyclohexane in the Eastern Arctic Ocean; *Environ. Sci. Technol.* 1999, **33**, 1157–1164.
128. Ridal, J.J.; Bidleman, T.F.; Kerman, B.R.; Fox, M.E.; Strachan, W.M.J., Enantiomers of α -hexachlorocyclohexane as tracers of air-water gas exchange in Lake Ontario; *Environ. Sci. Technol.* 1997, **31**, 1940–1945.
129. Padma, T.V.; Dickhut, R.M., Spatial and temporal variation in hexachlorocyclohexane isomers in a temperate estuary; *Mar. Poll. Bull.* 2002, **44**, 1345–1353.
130. Padma, T.V.; Dickhut, R.M.; Ducklow, H., Variations in α -hexachlorocyclohexane enantiomer ratios in relation to microbial activity in a temperate estuary; *Environ. Toxicol. Chem.* 2003, **22**, 1421–1427.
131. Jantunen, L.M.; Kylin, H.; Bidleman, T.F., Air-water gas exchange of α -hexachlorocyclohexane enantiomers in the South Atlantic Ocean and Antarctica; *Deep-Sea Res. II* 2004, **51**, 2661–2672.
132. Buser, H.-R.; Müller, M.D., Isomer and enantioselective degradation of hexachlorocyclohexane isomers in sewage sludge under anaerobic conditions; *Environ. Sci. Technol.* 1995, **29**, 664–672.
133. Carballa, M.; Omil, F.; Lema, J.M., Calculation methods to perform mass balances of micro-pollutants in sewage treatment plants. Application to pharmaceutical and personal care products (PPCPs); *Environ. Sci. Technol.* 2007, **41**, 884–890.
134. Yang, J.J.; Metcalfe, C.D., Fate of synthetic musks in a domestic wastewater treatment plant and in an agricultural field amended with biosolids; *Sci. Total Environ.* 2006, **363**, 149–165.
135. Berset, J.D.; Kupper, T.; Etter, R.; Tarradellas, J., Considerations about the enantioselective transformation of polycyclic musks in wastewater, treated wastewater and sewage sludge and analysis of their fate in a sequencing batch reactor plant; *Chemosphere* 2004, **57**, 987–996.

136. Gerecke, A.C.; Giger, W.; Hartman, P.C.; Heeb, N.V.; Kohler, H.-P.E.; Schmid, P.; Zennegg, M.; Kohler, M., Anaerobic degradation of brominated flame retardants in sewage sludge; *Chemosphere* 2006, **64**, 311–317.
137. Moisey, J.; Fisk, A.T.; Hobson, K.A.; Norstrom, R.J., Hexachlorocyclohexane (HCH) isomers and chiral signatures of α -HCH in the Arctic marine food web of the Northwater Polynya; *Environ. Sci. Technol.* 2001, **35**, 1920–1927.
138. Bidleman, T.F.; Wong, F.; Backe, C.; Södergren, A.; Brorström-Lundén, E.; Helm, P.A.; Stern, G.A., Chiral signatures of chlordanes indicate changing sources to the atmosphere over the past 30 years; *Atmos. Environ.* 2004, **38**, 5963–5970.
139. Stern, G.A.; Braekevelt, E.; Helm, P.A.; Bidleman, T.F.; Outridge, P.M.; Lockhart, W.L.; McNeeley, R.; Rosenberg, B.; Ikononou, M.G.; Hamilton, P.; Tomy, G.T.; Wilkinson, P., Modern and historical fluxes of halogenated organic contaminants to a lake in the Canadian arctic, as determined from annually laminated sediment cores; *Sci. Total Environ.* 2005, **342**, 223–243.
140. Kurt-Karakus, P.B.; Bidleman, T.F.; Jones, K.C., Chiral organochlorine pesticide signatures in global background soils; *Environ. Sci. Technol.* 2005, **39**, 8671–8677.
141. Li, X.; Yang, L.; Jans, U.; Melcer, M.E.; Zhang, P., Lack of enantioselective microbial degradation of chlordane in Long Island Sound sediment; *Environ. Sci. Technol.* 2007, **41**, 1635–1640.
142. Falconer, R.L.; Bidleman, T.F.; Szeto, S.Y., Chiral pesticides in soils of the Fraser Valley, British Columbia; *J. Agric. Food Chem.* 1997, **45**, 1946–1951.
143. Aigner, E.J.; Leone, A.D.; Falconer, R.L., Concentrations and enantiomeric ratios of organochlorine pesticides in soils from the U.S. Corn Belt; *Environ. Sci. Technol.* 1998, **32**, 1162–1168.
144. Leone, A.D.; Amato, S.; Falconer, R.L., Emission of chiral organochlorine pesticides from agricultural soils in the Cornbelt region of the U.S.; *Environ. Sci. Technol.* 2001, **35**, 4592–4596.
145. Wiberg, K.; Harner, T.; Wideman, J.L.; Bidleman, T.F., Chiral analysis of organochlorine pesticides in Alabama soils; *Chemosphere* 2001, **45**, 843–848.
146. Bidleman, T.F.; Leone, A.D.; Wong, F.; Van Vliet, L.; Szeto, S.; Ripley, B.D., Emission of legacy chlorinated pesticides from agricultural and orchard soils in British Columbia, Canada; *Environ. Toxicol. Chem.* 2006, **25**, 1448–1457.
147. Daly, G.L.; Lei, Y.D.; Teixeira, C.; Muir, D.C.G.; Castillo, L.E.; Jantunen, L.M.M.; Wania, F., Organochlorine pesticides in the soils and atmosphere of Costa Rica; *Environ. Sci. Technol.* 2007, **41**, 1124–1130.
148. Wong, F.; Robson, M.; Diamond, M.L.; Harrad, S.; Truong, J., Concentrations and chiral signatures of POPs in soils and sediments: A comparative urban versus rural study in Canada and UK; *Chemosphere* 2009, **74**, 404–411.
149. Vetter, W.; Bartha, R.; Stern, G.; Tomy, G., Enantioselective determination of two persistent chlorobornane congeners in sediment from a toxaphene-treated Yukon lake; *Environ. Toxicol. Chem.* 1999, **18**, 2775–2781.
150. Fingerling, G.; Hertkorn, N.; Parlar, H., Formation and spectroscopic investigation of two hexachlorobornanes from six environmentally relevant toxaphene compounds by reductive dechlorination in soil under anaerobic conditions; *Environ. Sci. Technol.* 1996, **30**, 2984–2992.
151. Vetter, W.; Maruya, K.A., Congener and enantioselective analysis of toxaphene in sediment and food web of a contaminated estuarine wetland; *Environ. Sci. Technol.* 2000, **34**, 1627–1635.
152. Ngabe, B.; Bidleman, T.F., DDT concentrations in soils of Brazzaville, Congo; *Bull. Environ. Contam. Toxicol.* 2006, **76**, 697–704.
153. Bedard, D.L.; Wagner, R.E.; Brennan, M.J.; Haberl, M.L.; Brown, J.F. Jr., Extensive degradation of Aroclors and environmentally transformed polychlorinated biphenyls by *Alcaligenes eutrophus* H850; *Appl. Environ. Microbiol.* 1987, **53**, 1094–1102.
154. Abramowicz, D.A.; Brennan, M.J.; van Dort, H.M.; Gallagher, E.L., Factors influencing the rate of polychlorinated biphenyl dechlorination in Hudson River sediments; *Environ. Sci. Technol.* 1993, **27**, 1125–1131.
155. Bedard, D.L.; Quensen J.F. III, Microbial Reductive Dechlorination of Polychlorinated Biphenyls; In: *Microbial Transformation and Degradation of Toxic Organic Chemicals*, L.Y. Young; C.E. Cerniglia, editors, Wiley–Liss; New York, 1995, p. 127–216.

156. Wong, C.S.; Pakdeesusuk, U.; Morrissey, J.A.; Lee, C.M.; Coates, J.T.; Garrison, A.W.; Mabury, S.A.; Marvin, C.H.; Muir, D.C.G., Enantiomeric composition of chiral polychlorinated biphenyl atropisomers in dated sediment cores; *Environ. Toxicol. Chem.* 2007, **26**, 254–263.
157. Marvin, C.H.; Charlton, M.N.; Stern, G.A.; Braekvelt, E.; Reiner, E.J.; Painter, S., Spatial and temporal trends in sediment contamination in Lake Ontario; *J. Great Lakes Res.* 2003, **29**, 317–331.
158. Eisenreich, S.J.; Capel, P.D.; Robbins, J.A.; Bourbonniere, R., Accumulation and diagenesis of chlorinated hydrocarbons in lacustrine sediments; *Environ. Sci. Technol.* 1989, **23**, 1116–1126.
159. Wong, C.S.; Sanders, G.; Engstrom, D.R.; Long, D.T.; Swackhamer, D.L.; Eisenreich, S.J., Accumulation, inventory, and diagenesis of chlorinated hydrocarbons in Lake Ontario sediments; *Environ. Sci. Technol.* 1995, **29**, 2661–2672.
160. Wong, C.S.; Garrison, A.W.; Foreman, W.T., Enantiomeric composition of chiral polychlorinated biphenyl atropisomers in aquatic bed sediment; *Environ. Sci. Technol.* 2001, **35**, 33–39.
161. Farley, K.J.; Germann, G.G.; Elzerman, A.W., Differential weathering of PCB congeners in Lake Hartwell, South Carolina; In: *Environmental Chemistry of Lakes and Reservoirs*, Baker, L.A., editor, American Chemical Society; Washington DC, 1994, p. 575–600.
162. Magar, V.S.; Brenner, R.C.; Johnson, G.W.; Quensen, J.F. III, Long-term recovery of PCB-contaminated sediments at the Lake Hartwell Superfund site: PCB dechlorination. 2. Rates and extent; *Environ. Sci. Technol.* 2005, **39**, 3548–3554.
163. Pakdeesusuk, U.; Jones, W.J.; Lee, C.M.; Garrison, A.W.; O'Neill, W.L.; Coates, J.T.; Wong, C.S., Changes in enantiomeric fraction (EF) during microbial reductive dechlorination of PCB 132, PCB 149, and Aroclor 1254 in Lake Hartwell sediment microcosms; *Environ. Sci. Technol.* 2003, **37**, 1100–1107.
164. García-Ruiz, C.; Andrés, R.; Valera, J.L.; Laborda, F.; Marina, M.L., Monitoring the stereoselectivity of biodegradation of chiral polychlorinated biphenyls using electrokinetic chromatography; *J. Sep. Sci.* 2002, **25**, 17–22.
165. Singer, A.C.; Wong, C.S.; Crowley, D.E., Differential enantioselective transformation of atropisomeric polychlorinated biphenyls by multiple bacterial strains with differing inducing compounds; *Appl. Environ. Microbiol.* 2002, **68**, 5756–5759.
166. Asturias, J.A.; Diaz, E.; Timmis, K.N., The evolutionary relationship of biphenyl dioxygenase from Gram-positive *Rhodococcus globerulus* P6 to multicomponent dioxygenases from gram-negative bacteria; *Gene* 1995, **156**, 11–18.
167. Finizio, A.; Bidleman, T.F.; Szeto, S.Y., Emission of chiral pesticides from an agricultural soil in the Fraser Valley, British Columbia; *Chemosphere* 1998, **36**, 345–355.
168. Jantunen, L.M.M.; Bidleman, T.F.; Harner, T.; Parkhurst, W.J., Toxaphene, chlordane, and other organochlorine pesticides in Alabama air; *Environ. Sci. Technol.* 2000, **34**, 5097–5105.
169. Bidleman, T.F.; Leone, A.D., Soil-air exchange of organochlorine pesticides in the Southern United States; *Environ. Pollut.* 2004, **128**, 49–57.
170. Li, J.; Zhang, G.; Qi, S.; Li, X.; Peng, X.; Concentrations, enantiomeric compositions, and sources of HCH, DDT, and chlordane in soils from the Pearl River Delta, South China; *Sci. Total Environ.* 2006, **372**, 215–224.
171. Ulrich, E.M.; Hites, R.A., Enantiomeric ratios of chlordane-related compounds in air near the Great Lakes; *Environ. Sci. Technol.* 1998, **32**, 1870–1874.
172. Shen, L.; Wania, F.; Lei, Y.D.; Teixeira, C.; Muir, D.C.G.; Bidleman, T.F., Atmospheric distribution and long-range transport behavior of organochlorine pesticides in North America; *Environ. Sci. Technol.* 2005, **38**, 409–420.
173. Shen, L.; Wania, F.; Lei, Y.D.; Teixeira, C.; Muir, D.C.G.; Bidleman, T.F., Hexachlorocyclohexanes in the North American atmosphere; *Environ. Sci. Technol.* 2004, **38**, 965–975.
174. Meijer, S.N.; Halsall, C.J.; Harner, T.; Peters, A.J.; Ockenden, W.A.; Johnston, A.E.; Jones, K.C., Organochlorine pesticide residues in archived UK soil; *Environ. Sci. Technol.* 2001, **35**, 1989–1995.
175. Eitzer, B.D.; Mattina, M.I.; Iannucci-Berger, W., Compositional and chiral profiles of weathered chlordane residues in soil; *Environ. Toxicol. Chem.* 2001, **20**, 2198–2204.
176. White, J.C.; Mattina, M.I.; Eitzer, B.D.; Iannucci-Berger, W., Tracking chlordane compositional and chiral profiles in soil and vegetation; *Chemosphere* 2002, **47**, 639–646.

177. Mattina, M.I.; White, J.; Eitzer, B.; Iannucci-Berger, W., Cycling of weathered chlordane residues in the environment: Compositional and chiral profiles in contiguous soil, vegetation, and air compartments; *Environ. Toxicol. Chem.* 2002, **21**, 281–288.
178. Mattina, M.I.; Isleyen, M.; Eitzer, B.; Iannucci-Berger, W.; White, J.C., Uptake by cucurbitaceae of soil-borne contaminants depends upon plant genotype and pollutant properties; *Environ. Sci. Technol.* 2006, **40**, 1814–1821.
179. Kelly, B.C.; Ikonomou, M.G.; Blair, J.D.; Morin, A.E.; Gobas, F.A.P.C., Food web-specific biomagnification of persistent organic pollutants; *Science* 2007, **317**, 236–239.
180. Kurt-Karakus, P.B.; Stroud, J.L.; Bidleman, T.; Semple, K.T.; Jantunen, L.; Jones, K.C., Enantioselective degradation of organochlorine pesticides in background soils: Variability in field and laboratory studies; *Environ. Sci. Technol.* 2007, **41**, 4965–4971.
181. Lewis, D.L.; Garrison, A.W.; Wommack, E.; Whittemore, A.; Steudler, P.; Melillo, J., Influence of environmental changes on degradation of chiral pollutants in soils; *Nature* 1999, **401**, 898–901.
182. Robson, M.; Harrad, S., Chiral PCB signatures in air and soil: Implications for atmospheric source apportionment; *Environ. Sci. Technol.* 2004, **38**, 1662–1666.
183. Jamshidi, A.; Hunter, S.; Hazrati, S.; Harrad, S., Concentrations and chiral signatures of polychlorinated biphenyls in outdoor and indoor air and soil in a major U.K. conurbation; *Environ. Sci. Technol.* 2007, **41**, 2153–2158.
184. Harrad, S.; Ren, J.; Hazrati, S.; Robson, M., Chiral signatures of PCBs 95 and 149 in indoor air, grass, duplicate diets and human faeces; *Chemosphere* 2006, **63**, 1368–1376.
185. Qin, S.; Gan, J., Enantiomeric differences in permethrin degradation pathways in soil and sediment; *J. Agric. Food Chem.* 2006, **54**, 9145–9151.
186. Klump, J.V.; Kaster, J.L.; Sierszen, M.E., *Mysis relicta* assimilation of hexachlorobiphenyl from sediments; *Can. J. Fish. Aquat. Sci.* 1991, **48**, 284–289.
187. Landrum, P.F.; Frez, W.A.; Simmons, M.S., The effect of food consumption on the toxicokinetics of benzo(a)pyrene and 2,2',4,4',5,5'-hexachlorobiphenyl in *Mysis relicta*; *Chemosphere* 1992, **25**, 397–415.
188. Landrum, P.F.; Nalepa, T.F., A review of the factors affecting the ecotoxicity of *Diporeia* spp.; *J. Great Lakes Res.* 1998, **24**, 889–904.
189. Hoekstra, P.F.; Wong, C.S.; O'Hara, T.M.; Solomon, K.R.; Mabury, S.A.; Muir, D.C.G., Enantiomer-specific accumulation of PCB atropisomers in the bowhead whale (*Balaena mysticetus*); *Environ. Sci. Technol.* 2002, **36**, 1419–1425.
190. Hoekstra, P.F.; O'Hara, T.M.; Karlsson, H.; Solomon, K.R.; Muir, D.C.G., Enantiomer-specific biomagnification of α -hexachlorocyclohexane and selected chiral chlordane-related compounds within an Arctic marine food web; *Environ. Toxicol. Chem.* 2003, **22**, 2482–2491.
191. Borgå, K.; Bidleman, T.F., Enantiomer fractions of organic chlorinated pesticides in Arctic marine ice fauna, zooplankton, and benthos; *Environ. Sci. Technol.* 2005, **39**, 3464–3473.
192. Warner, N.A.; Norstrom, R.J.; Wong, C.S.; Fisk, A.T., Enantiomeric fractions of chiral PCBs provide insights on biotransformation capacity of Arctic biota; *Environ. Toxicol. Chem.* 2005, **24**, 2763–2767.
193. Tomy, G.T.; Pleskach, K.; Oswald, T.; Halldorson, T.; Helm, P.A.; MacInnis, G.; Marvin, C.H., Enantioselective bioaccumulation of hexabromocyclododecane and congener-specific accumulation of brominated diphenyl ethers in an eastern Canadian arctic marine food web; *Environ. Sci. Technol.* 2008, **42**, 3634–3639.
194. Asher, B.J.; Wong, C.S.; Rodenburg, L.A., Chiral source apportionment of polychlorinated biphenyls to the Hudson River estuary atmosphere and food web; *Environ. Sci. Technol.* 2007, **41**, 6163–6169.
195. Corsolini, S.; Covaci, A.; Ademollo, N.; Focardi, S.; Schepens, P., Occurrence of organochlorine pesticides (OCPs) and their enantiomeric signatures, and concentrations of polybrominated diphenyl ethers (PBDEs) in the Adélie penguin food web, Antarctica; *Environ. Pollut.* 2006, **140**, 371–382.
196. Wong, C.S.; Garrison, A.W.; Smith, P.D.; Foreman, W.T., Enantiomeric composition of chiral polychlorinated biphenyl atropisomers in aquatic and riparian biota; *Environ. Sci. Technol.* 2001, **35**, 2448–2454.

197. Gatermann, R.; Biselli, S.; Hühnerfuss, H.; Rimkus, G.G.; Franke, S.; Hecker, M.; Kallenborn, R.; Karbe, L.; König, W.A., Synthetic musks in the environment. Part 2: Enantioselective transformation of the polycyclic musks fragrances HHCb, AHTN, AHDI and ATII in freshwater fish; *Arch. Environ. Contam. Toxicol.* 2002, **42**, 447–453.
198. Wong, C.S.; Mabury, S.A.; Whittle, D.M.; Backus, S.M.; Teixeira, C.; DeVault, D.S.; Bronte, C.R.; Muir, D.C.G., Polychlorinated biphenyls in Lake Superior: Chiral congeners and biotransformation in the aquatic food web; *Environ. Sci. Technol.* 2004, **38**, 84–92.
199. Warner, N.A.; Wong, C.S., The freshwater invertebrate *Mysis relicta* can eliminate chiral organochlorine compounds enantioselectively; *Environ. Sci. Technol.* 2006, **40**, 4158–4164.
200. Stegeman, J.J.; Klopper-Sams, P.J., Cytochrome P-450 isozymes and monooxygenase activity in aquatic animals; *Environ. Health Perspect.* 1987, **71**, 87–95.
201. Kleinow, K.M.; Melancon, M.J.; Lech, J.J., Biotransformation and induction: Implications for toxicity, bioaccumulation, and monitoring of environmental xenobiotics in fish; *Environ. Health Perspect.* 1987, **71**, 105–119.
202. James, M.O., Cytochrome P450 monooxygenases in crustaceans; *Xenobiotica* 1989, **19**, 1063–1076.
203. Livingstone, D.R.; Kirchin, M.A.; Wiseman, A., Cytochrome P-450 and oxidative metabolism in molluscs; *Xenobiotica* 1989, **19**, 1041–1062.
204. Melancon, Jr. M.J.; Lech, J.J., Isolation and identification of a polar metabolite of tetrachlorobiphenyl from bile of rainbow trout exposed to ¹⁴C-tetrachlorobiphenyl; *Bull. Environ. Contam. Toxicol.* 1976, **15**, 181–188.
205. Hutzinger, O.; Nash, D.M.; Safe, S.; DeFreitas, A.S.W.; Norstrom, R.J.; Wildish, D.J.; Zitko, V., Polychlorinated biphenyls: Metabolic behavior of pure isomers in pigeons, rats, and brook trout; *Science* 1978, **178**, 312–314.
206. McFarland, V.A.; Clarke, J.U., Environmental occurrence, abundance, and potential toxicity of polychlorinated biphenyl congeners: Considerations for a congener-specific analysis; *Environ. Health Perspect.* 1989, **81**, 225–239.
207. Boon, J.P.; Eijgenraam, F.; Everaarts, J.M.; Duinker, J.C., A structure-activity relationship (SAR) approach towards metabolism of PCBs in marine animals from different trophic levels; *Mar. Environ. Res.* 1989, **27**, 159–176.
208. Brown, J.F. Jr., Metabolic alterations of PCB residues in aquatic fauna: distributions of cytochrome P4501A- and P4502B-like activities; *Mar. Environ. Res.* 1992, **34**, 261–266.
209. Norstrom, R.J.; Muir, D.C.G.; Ford, C.A.; Simon, M.; Macdonald, C.R.; Béland, P., Indications of P450 monooxygenase activities in beluga whale (*Delphinapterus leucas*) and narwhal (*Monodon monoceros*) from patterns of PCB, PCDD and PCDF accumulation; *Mar. Environ. Res.* 1992, **34**, 267–272.
210. Kannan, N.; Reusch, T.B.H.; Schulz-Bull, D.E.; Petrick, G.; Duinker, J.C., Chlorobiphenyls: Model compounds for metabolism in food chain organisms and their potential use as ecotoxicological stress indicators by application of the metabolic slope concept; *Environ. Sci. Technol.* 1995, **29**, 1851–1859.
211. Niimi, A.J., Evaluation of PCBs and PCDD/Fs retention by aquatic organisms; *Sci. Total Environ.* 1996, **192**, 123–150.
212. Thomann, R.V., Bioaccumulation model of organic chemical distribution in aquatic food chains; *Environ. Sci. Technol.* 1989, **23**, 699–707.
213. Gobas, F.A.P.C., A model for predicting the bioaccumulation of hydrophobic organic compounds in aquatic food-webs: Application to Lake Ontario; *Ecol. Modell.* 1993, **69**, 1–17.
214. Vetter, W.; Krock, B.; Klobes, U.; Luckas, B., Enantioselective analysis of a heptachlorobornane isolated from the technical product Malipax by gas chromatography/mass spectrometry; *J. Agric. Food Chem.* 1997, **45**, 4866–4870.
215. Koske, G.; Leupold, G.; Angerhöfer, D.; Parlar, H., Multidimensional gas chromatographic enantiomer identification of some chlorinated xenobiotics in cod liver and fish oils; *Chemosphere* 1999, **39**, 683–688.

216. Wiberg, K.; Letcher, R.J.; Sandau, C.D.; Norstrom, R.J.; Tysklind, M.; Bidleman, T.F., The enantioselective bioaccumulation of chiral chlordane and α -HCH contaminants in the polar bear food chain; *Environ. Sci. Technol.* 2000, **34**, 2668–2674.
217. Buser, H.-R.; Müller, M.D., Enantiomer separation of chlordane components and metabolites using high-resolution gas chromatography and detection by mass spectrometric techniques; *Anal. Chem.* 1992, **64**, 3168–3175.
218. Buser, H.-R.; Müller, M.D., Isomer- and Enantiomer-selective analyses of toxaphene components using chiral high-resolution gas chromatography and detection by mass spectrometry/mass spectrometry; *Environ. Sci. Technol.* 1994, **28**, 119–128.
219. Wiberg, K.; Oehme, M.; Haglund, P.; Karlsson, H.; Olsson, M.; Rappe, C., Enantioselective analysis of organochlorine pesticides in herring and ringed seal from the Swedish marine environment; *Mar. Poll. Bull.* 1998, **36**, 345–353.
220. Karlsson, H.; Oehme, M.; Skopp, S.; Burkow, I.C., Enantiomer ratios of chlordane congeners are gender specific in cod (*Gadus morhua*) from the Barents Sea; *Environ. Sci. Technol.* 2000, **34**, 2126–2130.
221. Wiberg, K.; Bergman, A.; Olsson, M.; Roos, A.; Blomkvist, G.; Haglund, P., Concentrations and enantiomer fractions of organochlorine compounds in Baltic seals hit by reproductive impairment; *Environ. Toxicol. Chem.* 2002, **21**, 2452–2551.
222. Blanch, G.P.; Glausch, A.; Schurig, V.; Gonzalez, M.J., Quantification and determination of enantiomeric ratios of chiral PCB 95, PCB 132, and PCB 149 in shark liver samples (*C. coelelepis*) from the Atlantic Ocean; *J. High Resol. Chromatogr.* 1996, **19**, 392–396.
223. Bethan, B.; Bester, K.; Hühnerfuss, H.; Rimkus, G., Bromocyclen contamination of surface water, waste water and fish from northern Germany, and gas chromatographic chiral separation; *Chemosphere* 1997, **34**, 2271–2280.
224. Vetter, W.; Smalling, K.L.; Maruya, K.A., Interpreting nonracemic ratios of chiral organochlorines using naturally contaminated fish; *Environ. Sci. Technol.* 2001, **35**, 4444–4448.
225. Maruya, K.A.; Smalling, K.L.; Vetter, W., Temperature and congener structure affect the enantioselectivity of toxaphene elimination by fish; *Environ. Sci. Technol.* 2005, **39**, 3999–4004.
226. Seemamahannop, R.; Berthod, A.; Maples, M.; Kapila, S.; Armstrong, D.W., Uptake and enantioselective elimination of chlordane compounds by common carp (*Cyprinus carpio*, L.); *Chemosphere* 2005, **59**, 493–500.
227. Wong, C.S.; Lau, F.; Clark, M.; Mabury, S.A.; Muir, D.C.G., Rainbow trout (*Oncorhynchus mykiss*) can eliminate chiral organochlorine compounds enantioselectively; *Environ. Sci. Technol.* 2002, **36**, 1257–1262.
228. Kleinow, K.M.; Haasch, M.L.; Williams, D.E.; Lech, J.J., A comparison of hepatic P450 induction in rat and trout (*Oncorhynchus mykiss*): Delineation of the site of resistance of fish to phenobarbital-type inducers; *Comp. Biochem. Physiol. Part C* 1990, **96**, 259–270.
229. Buckman, A.H.; Brown, S.B.; Small, J.; Muir, D.C.G.; Parrott, J.; Solomon, K.R.; Fisk, A.T., Role of temperature and enzyme induction in the biotransformation of polychlorinated biphenyls and bioformation of hydroxylated polychlorinated biphenyls by rainbow trout (*Oncorhynchus mykiss*); *Environ. Sci. Technol.* 2007, **41**, 3856–3863.
230. Wiberg, K.; Andersson, P.L.; Berg, H.; Olsson, P.-E.; Haglund, P., The fate of chiral organochlorine compounds and selected metabolites in intraperitoneally exposed Arctic char (*Salvelinus alpinus*); *Environ. Toxicol. Chem.* 2006, **25**, 1465–1473.
231. Konwick, B.J.; Garrison, A.W.; Black, M.C.; Avants, J.K.; Fisk, A.T., Bioaccumulation, biotransformation, and metabolite formation of fipronil and chiral legacy pesticides in rainbow trout; *Environ. Sci. Technol.* 2006, **40**, 2930–2936.
232. Buckman, A.H.; Wong, C.S.; Chow, E.A.; Brown, S.B.; Solomon, K.R.; Fisk, A.T., Biotransformation of polychlorinated biphenyls (PCBs) and bioformation of hydroxylated PCBs in fish; *Aquat. Toxicol.* 2006, **78**, 176–185.
233. Bright, D.A.; Grundy, S.L.; Reimer, K.J., Differential bioaccumulation of non-ortho-substituted and other PCB congeners in coastal Arctic invertebrates and fish; *Environ. Sci. Technol.* 1995, **29**, 2504–2512.

234. Stapleton, H.M.; Letcher, R.J.; Baker, J.E., Metabolism of PCBs by the deepwater sculpin (*Myoxocephalus thompsoni*); *Environ. Sci. Technol.* 2001, **35**, 4747–4752.
235. Franke, S.; Meyter, C.; Heinzel, N.; Gatermann, R.; Hühnerfuss, H.; Rimkus, G.; König, W.A.; Francke, W., Enantiomeric composition of the polycyclic musks HHCB and AHTN in different aquatic species; *Chirality* 1999, **11**, 795–801.
236. Janák, K.; Sellström, U.; Johannsson, A.-K.; Becher, G.; de Wit, C.A.; Lindberg, P.; Helander, B., Enantiomer-specific accumulation of hexabromocyclododecanes in eggs of predatory birds; *Chemosphere* 2008, **73**, S193–S200.
237. Hiebl, J.; Vetter, W., Detection of hexabromocyclododecane and its metabolite pentabromocyclododecene in chicken egg and fish from the official food control; *J. Agric. Food Chem.* 2007, **55**, 3319–3324.
238. Kallenborn, R.; Hühnerfuss, H.; König, W., Enantioselective metabolism of (\pm)- α -1, 2,3,4,5,6-hexachlorocyclohexane in organs of the Eider duck; *Angew. Chem. Int. Ed. Engl.* 1991, **30**, 320–321.
239. Möller, K.; Hühnerfuss, H.; Rimkus, G., On the diversity of enzymatic degradation pathways of α -hexachlorocyclohexane as determined by chiral gas chromatography; *J. High Resol. Chromatogr.* 1993, **16**, 672–673.
240. Iwata, H.; Tanabe, S.; Iida, T.; Baba, N.; Ludwig, J.P.; Tatsukawa, R., Enantioselective accumulation of α -hexachlorocyclohexane in northern fur seals and double-crested cormorants: Effects of biological and ecological factors in the higher trophic levels; *Environ. Sci. Technol.* 1998, **32**, 2244–2249.
241. Fisk, A.T.; Moisey, J.; Hobson, K.A.; Karnovsky, N.J.; Norstrom, R.J., Chlordane components and metabolites in seven species of Arctic seabirds from the Northwater Polynya: Relationships with stable isotopes of nitrogen and enantiomeric fractions of chiral components; *Environ. Pollut.* 2001, **113**, 225–238.
242. Vetter, W.; Scholz, E.; Luckas, B.; Maruya, K.A., Structure of a persistent heptachlorobornane in toxaphene (B7-1000) agrees with molecular model predictions; *J. Agric. Food Chem.* 2001, **49**, 759–765.
243. Karásek, L.; Hajšlová, J.; Rosmus, J.; Hühnerfuss, H., Methylsulfonyl PCB and DDE metabolites and their enantioselective gas chromatographic separation in human adipose tissues, seal blubber and pelican muscle; *Chemosphere* 2007, **67**, S22–S27.
244. Herzke, D.; Kallenborn, R.; Nygård, T., Organochlorines in egg samples from Norwegian birds of prey: Congener-, isomer- and enantiomer specific considerations; *Sci. Total Environ.* 2002, **291**, 59–71.
245. Gómara, B.; González, M.J., Enantiomeric fractions and congener specific determination of polychlorinated biphenyls in eggs of predatory birds from Doñana National Park (Spain); *Chemosphere* 2006, **63**, 662–669.
246. Jörundsdóttir, H.; Norström, K.; Olsson, M.; Pham-Tuan, H.; Hühnerfuss, H.; Bignert, A.; Bergman, Å., Temporal trend of bis(4-chlorophenyl) sulfone, methylsulfonyl-DDE and -PCBs in Baltic guillemot (*Uria aalge*) egg 1971–2001: A comparison to 4,4'-DDE and PCB trends; *Environ. Pollut.* 2006, **141**, 226–237.
247. Kallenborn, R.; Planting, S.; Haugen, J.-E., Congener-, isomer-, and enantiomer-specific distribution of organochlorines in dippers (*Cinclus cinclus L.*) from southern Norway; *Chemosphere* 1998, **37**, 2489–2499.
248. Ross, M.S.; Verreault, J.; Letcher, R.J.; Gabrielsen, G.W.; Wong, C.S., Chiral organochlorine contaminants in blood and eggs of glaucous gulls (*Larus hyperboreus*) from the Norwegian Arctic; *Environ. Sci. Technol.* 2008, **42**, 7181–7186.
249. von der Recke, R.; Mariussen, E.; Berger, U.; Götsch, A.; Herzke, D.; Vetter, W., Determination of the enantiomer fraction of PBB 149 by gas chromatography/electron capture negative ionization tandem mass spectrometry in the selected reaction monitoring mode; *Rapid Commun. Mass Spectrom.* 2005, **19**, 3719–3723.
250. Klobes, U.; Vetter, W.; Luckas, B.; Skirnisson, K.; Plötz, J., Levels and enantiomeric ratios of α -HCH, oxychlordane, and PCB 149 in blubber of harbour seals (*Phoca vitulina*) and grey seals (*Halichoerus grypus*) from Iceland and further species; *Chemosphere* 1998, **37**, 2501–2512.

251. Fisk, A.T.; Holst, M.; Hobson, K.A.; Duffe, J.; Moisey, J.; Norstrom, R.J., Persistent organochlorine contaminants and enantiomeric signatures of chiral pollutants in ringed seals (*Phoca hispida*) collected on the east and west side of the Northwater Polynya, Canadian Arctic; *Arch. Environ. Contam. Toxicol.* 2002, **42**, 118–226.
252. Mössner, S.; Spraker, T.R.; Becker, P.R.; Ballschmiter, K., Ratios of enantiomers of alpha-HCH and determination of alpha-, beta-, and gamma-HCH in brain and other tissues of neonatal Northern fur seals (*Callorhinus ursinus*); *Chemosphere* 1992, **24**, 1171–1180.
253. Hummert, K.; Vetter, W.; Luckas, B., Levels of alpha-HCH, lindane, and enantiomeric ratios of alpha-HCH in marine mammals from the northern hemisphere; *Chemosphere* 1995, **31**, 3489–3500.
254. Vetter, W.; Hummer, K.; Luckas, B.; Skírnisson, K., Organochlorine residues from several species from Western Iceland; *Sci. Total Environ.* 1995, **170**, 159–164.
255. Kallenborn, R.; Oehme, M.; Vetter, W.; Parlar, H., Enantiomer selective separation of toxaphene congeners isolated from seal blubber and obtained by synthesis; *Chemosphere* 1994, **28**, 89–98.
256. Vetter, W.; Klobes, U.; Krock, B.; Luckas, B.; Glotz, D.; Scherer, G., Isolation, structure elucidation, and identification of a further major toxaphene compound in environmental samples; *Environ. Sci. Technol.* 1997, **31**, 3023–3028.
257. Vetter, W.; Luckas, B., Enantioselective determination of persistent and partly degradable toxaphene congeners in high trophic level biota; *Chemosphere* 2000, **41**, 499–506.
258. van Hezik, C.M.; Letcher, R.J.; de Geus, H.-J.; Wester, P.G.; Goksyör, A.; Lewis, W.E.; Boon, J. P., Indications for the involvement of a CYP3A-like *iso*-enzyme in the metabolism of chlorobornane (Toxaphene) congeners in seals from inhibition studies with liver microsomes; *Aquat. Toxicol.* 2001, **51**, 319–333.
259. Ulrich, E.M.; Willett, K.L.; Caperell-Grant, A.; Bigsby, R.M.; Hites, R.A., Understanding enantioselective processes: A laboratory rat model for α -hexachlorocyclohexane accumulation; *Environ. Sci. Technol.* 2001, **35**, 1604–1609.
260. Wiberg, K.; Letcher, R.; Sandau, C.; Duffe, J.; Norstrom, R.; Haglund, P.; Bidleman, T. Enantioselective gas chromatography/mass spectrometry of methylsulfonyl PCBs with application to Arctic marine mammals; *Anal. Chem.* 1998, **70**, 3845–3852.
261. Larsson, C.; Norström, K.; Athanasiadis, I.; Bignert, A.; König, W.A.; Bergman, Å., Enantiomeric specificity of methylsulfonyl-PCBs and distribution of bis(4-chlorophenyl) sulfone, PCB, and DDE methyl sulfones in grey seal tissues; *Environ. Sci. Technol.* 2004, **38**, 4950–4955.
262. Tanabe, S.; Watanabe, S.; Kan, H.; Tatsukawa, R., Capacity and mode of PCB metabolism in small cetaceans; *Mar. Mamm. Sci.* 1988, **4**, 103–124.
263. Tanabe, S.; Kumaran, P.; Iwata, H.; Tatsukawa, R.; Miyazaki, N., Enantiomeric ratios of α -hexachlorocyclohexane in blubber of small cetaceans; *Mar. Poll. Res.* 1996, **32**, 27–31.
264. Chu, S.; Covaci, A.; Van de Vijver, K.; De Coen, W.; Blust, R.; Schepens, P., Enantiomeric signatures of chiral polychlorinated biphenyl atropisomers in livers of harbour porpoises (*Phocoena phocoena*) from the southern North Sea; *J. Environ. Monit.* 2003, **5**, 521–526.
265. Chu, S.; Covaci, A.; Haraguchi, K.; Voorspoels, S.; Van de Vijver K.; Das, K.; Bouquegneau, J.-M.; De Coen, W.; Blust, R.; Schepens, P., Levels and enantiomeric signatures of methyl sulfonyl PCB and DDE metabolites in liver of harbor porpoises (*Phocoena phocoena*) from the southern North Sea; *Environ. Sci. Technol.* 2003, **37**, 4573–4578.
266. Peck, A.M.; Pugh, R.S.; Moors, A.; Ellisor, M.B.; Porter, B.J.; Becker, P.R.; Kucklick, J.R., Hexabromocyclododecane in white-side dolphins: Temporal trend and stereoisomer distribution in tissues; *Environ. Sci. Technol.* 2008, **42**, 2650–2655.
267. Klobes, U.; Vetter, W.; Glotz, D.; Luckas, B.; Skírnisson, K.; Hersteinsson, P., Levels and enantiomeric ratios of chlorinated hydrocarbons in livers of Arctic fox (*Alopex lagopus*) and adipose tissue and liver of a polar bear (*Ursus maritimus*) sampled in Iceland; *Intern. J. Environ. Anal. Chem.* 1998, **69**, 67–81.
268. Hoekstra, P.F.; Braune, B.M.; Wong, C.S.; Williamson, M.; Elkin, M.; Muir, D.C.G., Profile of persistent chlorinated contaminants, including selected chiral compounds, in wolverine (*Gulo gulo*) livers from the Canadian Arctic; *Chemosphere* 2003, **53**, 551–560.

269. Covaci, A.; Gheorghe, A.; Schepens, P., Distribution of organochlorine pesticides, polychlorinated biphenyls and α -HCH enantiomers in pork tissues; *Chemosphere* 2004, **56**, 757–766.
270. Hühnerfuss, H.; Faller, J.; Kallenborn, R.; König, W.A.; Ludwig, P.; Pfaffenberger, B.; Oehme, M.; Rimkus, G., Enantioselective and nonenantioselective degradation of organic pollutants in the marine ecosystem; *Chirality* 1993, **5**, 393–399.
271. Skopp, S.; Oehme, M.; Drenth, H., Study of the enantioselective elimination of four toxaphene congeners in rat after intravenous administration by high resolution gas chromatography negative ion mass spectrometry; *Chemosphere* 2002, **46**, 1083–1090.
272. Bondy, G.S.; Coady, L.; Doucet, J.; Armstrong, C.; Kriz, R.; Liston, V.; Robertson, P.; Norstrom, R.; Moisey, J., Enantioselective and gender-dependent depletion of chlordane compounds from rat tissues; *J. Toxicol. Environ. Health Part A* 2005, **68**, 1917–1938.
273. Lehmler, H.-J.; Price, D.J.; Garrison, A.W.; Birge, W.J.; Robertson, L.W., Distribution of PCB 84 enantiomers in C57BL/6 mice; *Fresenius Environ. Bull.* 2003, **12**, 254–260.
274. Kania-Korwel, I.; Shaikh, N.S.; Hornbuckle, K.C.; Robertson, L.W.; Lehmler, H.J., Enantioselective disposition of PCB 136 (2,2',3,3',6,6'-hexachlorobiphenyl) in C57BL/6 mice after oral and intraperitoneal administration; *Chirality* 2007, **19**, 56–66.
275. Kania-Korwel, I.; Hornbuckle, K.C.; Robertson, L.W.; Lehmler, H.-J., Influence of dietary fat on the enantioselective disposition of 2,2',3,3',6,6'-hexachlorobiphenyl (PCB 136) in female mice; *Food Chem. Toxicol.* 2008, **46**, 637–644.
276. Kania-Korwel, I.; Hornbuckle, K.C.; Robertson, L.W.; Lehmler, H.-J., Dose-dependent enantiomeric enrichment of 2,2',3,3',6,6'-hexachlorodiphenyl in female mice; *Environ. Toxicol. Chem.* 2008, **27**, 299–305.
277. Kania-Korwel, I.; Hrycay, E.G.; Bandiera, S.M.; Lehmler, H.-J., 2,2',3,3',6,6'-Hexachlorobiphenyl (PCB 136) atropisomers interact enantioselectively with hepatic microsomal cytochrome P450 enzymes; *Chem. Res. Toxicol.* 2008, **21**, 1295–1303.
278. Kania-Korwel, I.; Xie, W.; Hornbuckle, K.C.; Robertson, L.W.; Lehmler, H.-J., Enantiomeric enrichment of 2,2',3,3',6,6'-hexachlorobiphenyl (PCB 136) in mice after induction of CYP enzymes; *Arch. Environ. Contam. Toxicol.* 2008, **55**, 510–517.
279. Kania-Korwel, I.; Garrison, A.W.; Avants, J.K.; Hornbuckle, K.C.; Robertson, L.W.; Sulkowski, W.W.; Lehmler, H.-J., Distribution of chiral PCBs in selected tissues in the laboratory rat; *Environ. Sci. Technol.* 2006, **40**, 3704–3710.
280. Larsson, C.; Ellerichmann, T.; Hühnerfuss, H.; Bergman, Å., Chiral PCB methyl sulfones in rat tissues after exposure to technical PCBs; *Environ. Sci. Technol.* 2002, **36**, 2833–2838.
281. Norström, K.; Eriksson, J.; Haglund, J.; Silvani, V.; Bergman, Å., Enantioselective formation of methyl sulfone metabolites of 2,2',3,3',4,6'-hexachlorobiphenyl in rats; *Environ. Sci. Technol.* 2006, **40**, 7649–7655.
282. Hühnerfuss, H.; Bergman, Å.; Larsson, C.; Peters, N.; Westendorf, J., Enantioselective transformation of atropisomeric PCBs or of their methylsulfonyl metabolites by rat hepatocytes?; *Organohalogen Compounds* 2003, **62**, 265–268.
283. Ueno, D.; Darling, C.; Alaei, M.; Campbell, L.; Pacepavicius, G.; Teixeira, C.; Muir, D., Detection of hydroxylated polychlorinated biphenyls (OH-PCBs) in the abiotic environment: Surface water and precipitation from Ontario, Canada; *Environ. Sci. Technol.* 2007, **41**, 1841–1848.
284. Warner, N.A.; Martin, J.W.; Wong, C.S., Chiral polychlorinated biphenyls are biotransformed enantioselectively by mammalian cytochrome P-450 isozymes to form hydroxylated metabolites; *Environ. Sci. Technol.* 2009, **43**, 114–121.
285. Bicker, W.; Lämmerhofer, M.; Lindner, W., Comment on “Stereoselective degradation kinetics of theta-cypermethrin in rats”; *Environ. Sci. Technol.* 2006, **40**, 7950–7951.
286. Shen, H.; Virtanen, H.E.; Main, K.M.; Kaleva, M.; Andersson, A.M.; Skakkebæk, N.E.; Toppari, J.; Schramm, K.-W., Enantiomeric ratios as an indicator of exposure processes for persistent pollutants in human placentas; *Chemosphere* 2006, **62**, 390–395.
287. Skopp, S.; Oehme, M.; Fürst, P., Enantiomer ratios, patterns and levels of toxaphene congeners in human milk from Germany; *J. Environ. Monit.* 2002, **4**, 389–394.

288. Chu, S.; Covaci, A.; Schepens, P., Levels and chiral signatures of persistent organochlorine pollutants in human tissues from Belgium; *Environ. Res.* 2003, **93**, 167–176.
289. Ellerichmann, T.; Bergman, Å.; Franke, S.; Hühnerfuss, H.; Jakobsson, E.; König, W.A.; Larsson, C., Gas chromatographic enantiomer separations of chiral PCB methyl sulfons and identification of selectively retained enantiomers in human liver; *Fresenius Environ. Bull.* 1998, **7**, 244–257.
290. Weiss, J.; Wallin, E.; Axmon, A.; Jönsson, B.A.G.; Åkesson, H.; Janák, K.; Hagmar, L.; Bergman, Å., Hydroxy-PCBs, PBDEs, and HBCDDs in serum from an elderly population of Swedish fishermen's wives and associations with bone density; *Environ. Sci. Technol.* 2006, **40**, 6282–6289.
291. Jeremiason, J.D.; Hornbuckle, K.C.; Eisenreich, S.J., PCBs in Lake Superior, 1978–1992: Decreases in water concentrations reflect loss by volatilization; *Environ. Sci. Technol.* 1994, **28**, 903–914.
292. DeVault, D.S.; Willford, W.A.; Helleberg, R.J.; Nortrup, D.A.; Rundberg, E.G.S.; Alwan, A.K.; Bautista, C., Contaminant trends in lake trout (*Salvelinus namaycush*) from the Upper Great Lakes; *Arch. Environ. Contam. Toxicol.* 1986, **15**, 349–356.
293. DeVault, D.S.; Clark, J.; Lahvis, G.; Weishaar, J., Contaminants and trends in fall run coho salmon; *J. Great Lakes Res.* 1988, **14**, 23–33.
294. Borgmann, U.; Whittle, D., Contaminant concentration trends in Lake Ontario lake trout (*Salvelinus namaycush*): 1977 to 1988; *J. Great Lakes Res.* 1991, **17**, 368–381.
295. Miller, M.A.; Madenjian, C.P.; Masnado, R.G., Patterns of organochlorine contamination in lake trout from Wisconsin waters of the Great Lakes; *J. Great Lakes Res.* 1992, **18**, 742–754.
296. Braune, B.M.; Donaldson, G.M.; Hobson, K.A., Contaminant residues in seabird eggs from the Canadian Arctic. Part I. Temporal trends 1975–1998; *Environ. Pollut.* 2001, **114**, 39–54.
297. Oliver, B.G.; Charlton, M.N.; Durham, R.W., Distribution, redistribution, and geochronology of polychlorinated biphenyl congeners and other chlorinated hydrocarbons in Lake Ontario sediments; *Environ. Sci. Technol.* 1989, **23**, 200–208.
298. Wong, C.S.; Capel, P.D.; Nowell, L.H., Organochlorine pesticides and PCBs in stream sediment and aquatic biota: Initial results from the National Water-Quality Assessment Program, 1992–1995; Water-Resources Investigations Report 00-4053, U. S. Geological Survey, 2000.
299. Webster, E.; Mackay, D.; Qiang, K., Equilibrium lipid partitioning concentrations as a multimedia synoptic indicator of contaminant levels and trends in aquatic ecosystems; *J. Great Lakes Res.* 1999, **25**, 318–329.
300. Smith, D.W., Analysis of rates of decline of PCBs in different Lake Superior media; *J. Great Lakes Res.* 2000, **26**, 152–163.
301. Hebert, C.E.; Norstrom, R.J.; Weseloh, D.V.C., A quarter century of environmental surveillance: The Canadian Wildlife Service's Great Lakes herring gull monitoring program; *Environ. Rev.* 1999, **7**, 147–166.
302. Fisk, A.T.; Norstrom, R.J.; Cymbalisty, C.D.; Muir, D.C.G., Dietary accumulation and depuration of hydrophobic organochlorines: Bioaccumulation parameters and their relationship with the octanol/water partition coefficient; *Environ. Toxicol. Chem.* 1998, **17**, 951–961.
303. Bidleman, T.F.; Falconer, R.L., Enantiomer ratios for apportioning two sources of chiral compounds; *Environ. Sci. Technol.* 1999, **33**, 2299–2301.
304. Bailey, R.; Barrie, L.A.; Halsall, C.J.; Fellin, P.; Muir, D.C.G., Atmospheric organochlorine pesticides in the western Canadian Arctic: Evidence of transpacific transport; *J. Geophys. Res.* 2000, **105** (D9), 11805–11811.
305. Killin, R.K.; Simonich, S.L.; Jaffe, D.A.; DeForest, C.L.; Wilson, G.R., Transpacific and regional atmospheric transport of anthropogenic semivolatile organic compounds to Cheeka Peak Observatory during the spring of 2002; *J. Geophys. Res.* 2004, **109**, D23S15.
306. Kurt-Karakus, P.B.; Bidleman, T.F.; Staebler, R.M.; Jones, K.C., Measurement of DDT fluxes from a historically treated agricultural soil in Canada; *Environ. Sci. Technol.* 2006, **40**, 4578–4585.

307. Leone, A.D.; Ulrich, E.M.; Bodnar, C.E.; Falconer, R.L.; Hites, R.A., Organochlorine pesticide concentrations and enantiomer fractions for chlordane in indoor air from the US cornbelt; *Atmos. Environ.* 2000, **34**, 4131–4138.
308. Gouin, T.; Jantunen, L.; Harner, T.; Blanchard, P.; Bidleman, T., Spatial and temporal trends of chiral organochlorine signatures in Great Lakes air using passive air samplers; *Environ. Sci. Technol.* 2007, **41**, 3877–3883.
309. Wong, F.; Alegria, H.A.; Jantunen, L.M.; Bidleman, T.F.; Salvador-Figueroa, M.; Gold-Bouchot, G.; Ceja-Moreno, V.; Waliszewski, S.M.; Infanzon, R., Organochlorine pesticides in soils and air of southern Mexico: Chemical profiles and potential for soil emissions; *Atmos. Environ.* 2008, **42**, 7737–7745.
310. Meijer, S.N.; Shoeib, M.; Jantunen, L.M.M.; Jones, K.C.; Harner, T., Air-soil exchange of organochlorine pesticides in agricultural soils. 1. Field measurements using a novel *in situ* sampling device; *Environ. Sci. Technol.* 2003, **37**, 1292–1299.
311. Eitzer, B.D.; Iannucci-Berger, W.; Mattina, M.I., Volatilization of weathered chiral and achiral chlordane residues from soil; *Environ. Sci. Technol.* 2003, **37**, 4887–4893.
312. Alcock, R.E.; Johnston, A.E.; McGrath, S.P.; Berrow, M.L.; Jones, K.C., Long term changes in the polychlorinated biphenyl content of United Kingdom soils; *Environ. Sci. Technol.* 1993, **27**, 1918–1923.
313. Harner, T.; Mackay, D.; Jones, K.C., Model of the long-term exchange of PCBs between soil and the atmosphere in the southern U.K.; *Environ. Sci. Technol.* 1995, **29**, 1200–1209.
314. Harrad, S.J.; Sewart, A.P.; Alcock, R.; Boumphrey, R.; Burnett, V.; Duarte-Davidson, R.; Halsall, C.; Sanders, G.; Waterhouse, K.; Wild, S.R.; Jones, K.C., Polychlorinated biphenyls (PCBs) in the British environment: Sinks, sources and temporal trends; *Environ. Pollut.* 1994, **85**, 131–146.
315. Totten, L.A.; Gigliotti, C.L.; Vanry, D.A.; Offenber, J.H.; Nelson, E.D.; Dachs, J.; Reinfelder, J.R.; Eisenreich, S.J., Atmospheric concentrations and deposition of polychlorinated biphenyls to the Hudson River estuary; *Environ. Sci. Technol.* 2004, **38**, 2568–2573.
316. Currado, G.M.; Harrad, S., Factors influencing atmospheric concentrations of polychlorinated biphenyls in Birmingham, U.K.; *Environ. Sci. Technol.* 2000, **34**, 78–82.
317. Halsall, C.J.; Lee, R.G.M.; Coleman, P.J.; Burnett, V.; Harding-Jones, P.; Jones, K.C., PCBs in U.K. urban air; *Environ. Sci. Technol.* 1995, **29**, 2368–2376.
318. Harrad, S.; Hazrati, S.; Ibarra, C., Concentrations of polychlorinated biphenyls in indoor air and polybrominated diphenyl ethers in indoor air and dust in Birmingham, United Kingdom: Implications for human exposure; *Environ. Sci. Technol.* 2006, **40**, 4633–4638.
319. Bamford, H.A.; Ko, F.C.; Baker, J.E., Seasonal and annual air-water exchange of polychlorinated biphenyls across Baltimore Harbor and the northern Chesapeake Bay; *Environ. Sci. Technol.* 2002, **36**, 4245–4252.
320. Totten, L.A.; Brunciak, P.A.; Gigliotti, C.L.; Dachs, J.; Gleen, T.R. IV; Nelson, E.D.; Eisenreich, S.J., Dynamic air-water exchange of polychlorinated biphenyls in the New York–New Jersey Harbor estuary; *Environ. Sci. Technol.* 2001, **35**, 3834–3840.
321. Yu, Z.; Chen, L.; Mai, B.; Wu, M.; Sheng, G.; Fu, J.; Peng, P., Diastereomer- and enantiomer-specific profiles of hexabromocyclododecane in the atmosphere of an urban city in South China; *Environ. Sci. Technol.* 2008, **42**, 3996–4001.
322. Venier, M.; Hites, R.A., Chiral organochlorine pesticides in the atmosphere; *Atmos. Environ.* 2007, **41**, 768–775.
323. Jantunen, L.M.; Bidleman, T.F., Reversal of the air–water gas exchange direction of hexachlorocyclohexanes in the Bering and Chukchi Seas: 1993 versus 1998; *Environ. Sci. Technol.* 1995, **29**, 1081–1089.
324. Jantunen, L.M.; Helm, P.A.; Kylin, H.; Bidleman, T.F., Hexachlorocyclohexanes (HCHs) in the Canadian Archipelago: 2. Air–water gas exchange of α - and γ -HCH; *Environ. Sci. Technol.* 2008, **42**, 465–470.
325. Bethan, B.; Dannecker, W.; Gerwig, H.; Hühnerfuss, H.; Schulz, M., Seasonal dependence of the chiral composition of α -HCH in coastal deposition at the North Sea; *Chemosphere* 2001, **44**, 591–597.

326. Jantunen, L.M.; Helm, P.A.; Ridal, J.J.; Bidleman, T.F., Air-water gas exchange of chiral and achiral organochlorine pesticides in the Great Lakes; *Atmos. Environ.* 2008, **42**, 8533–8542.
327. Wiberg, K.; Brorström-Lundén, E.; Wängberg, I.; Bidleman, T.F.; Haglund, P., Concentrations and fluxes of hexachlorocyclohexanes and chiral composition of α -HCH in environmental samples from the southern Baltic Sea; *Environ. Sci. Technol.* 2001, **35**, 4739–4746.
328. Hutt, A.J.; Caldwell, J., The metabolic chiral inversion of 2-arylpropionic acids: A novel route with pharmacological consequences; *J. Pharm. Pharmacol.* 1983, **35**, 693–704.
329. Buser, H.-R.; Poiger, T.; Müller, M.D., Occurrence and environmental behavior of the chiral pharmaceutical drug ibuprofen in surface waters and in wastewater; *Environ. Sci. Technol.* 1999, **33**, 2529–2535.
330. Leicht, W.; Fuchs, R.; Londershausen, M., Stability and biological activity of cyfluthrin isomers; *Pestic. Sci.* 1996, **48**, 325–332.
331. Maguire, R.J., Chemical and photochemical isomerization of deltamethrin; *J. Agric. Food Chem.* 1990, **38**, 1613–1617.
332. Perschke, H.; Hussain, M., Chemical isomerization of deltamethrin in alcohols; *J. Agric. Food Chem.* 1992, **40**, 686–690.
333. Qin, S.; Gan, J., Abiotic enantiomerization of permethrin and cypermethrin: Effects of organic solvents; *J. Agric. Food Chem.* 2007, **55**, 5734–5739.
334. Ruzo, L.O.; Homstead, R.L.; Casida, J.E., Pyrethroid photochemistry: Decamethrin; *J. Agric. Food Chem.* 1977, **25**, 1385–1394.
335. Ruzo, L.O.; Krishnamurthy, V.V.; Casida, J.E.; Gohre, K., Pyrethroid photochemistry: Influence of the chloro(trifluoromethyl)vinyl substituent in cyhalothrin; *J. Agric. Food Chem.* 1987, **35**, 879–883.
336. Budakowski, W.; Tomy, G., Congener-specific analysis of hexabromocyclododecane by high-performance liquid chromatography/electrospray tandem mass spectrometry; *Rapid Commun. Mass Spectrom.* 2003, **17**, 1399–1404.
337. Tomy, G.T.; Halldorson, T.; Danell, R.; Law, K.; Arsenault, G.; Alaee, M.; MacInnis, G.; Marvin, C.H., Refinements to the diastereoisomer-specific method for the analysis of hexabromocyclododecane; *Rapid Commun. Mass Spectrom.* 2005, **19**, 2819–2826.
338. Guerra, P.; de la Torre, A.; Martínez, M.A.; Eljarrat, E.; Barceló, D., Identification and trace level determination of brominated flame retardants by liquid chromatography/quadrupole linear ion trap mass spectrometry; *Rapid Commun. Mass Spectrom.* 2008, **22**, 916–924.
339. MacLeod, S.L.; Sudhir, P.; Wong, C.S., Stereoisomer analysis of wastewater-derived beta-blockers, selective serotonin re-uptake inhibitors, and salbutamol by high-performance liquid chromatography-tandem mass spectrometry; *J. Chromatogr. A* 2007, **1170**, 23–33.
340. Asher, B.J.; D'Agostino, L.A.; Way, J.D.; Wong, C.S.; Harynuk, J.J., Comparison of peak integration methods for the determination of enantiomeric fraction in environmental samples; *Chemosphere* 2009, **75**, 1042–1048.
341. Garrison, A.W.; Nzungu, V.A.; Avants, J.K.; Ellington, J.J.; Jones, W.J.; Rennels, D.; Wolfe, N.L., Phytodegradation of *p,p'*-DDT and the enantiomers of *o,p'*-DDT; *Environ. Sci. Technol.* 2000, **34**, 1663–1670.

5

Persistent Organic Pollutants in the Developing World

Bondi Gevao¹, Henry Alegria², Foday M. Jaward³ and Mirza U. Beg¹

*¹Department of Environmental Science, Environment and Urban Development Division, Kuwait
Institute for Scientific Research, Safat, Kuwait*

*²Department of Environmental and Occupational Health, College of Public Health,
University of South Florida, Tampa, Florida, USA*

*³Department of Environmental Science, Policy and Geography, University of South
Florida, St Petersburg, Florida, USA*

5.1 Introduction

Persistent organic pollutants are a group of diverse chemicals that are persistent in the environment; having long half-lives in soils, sediments, air and biota; are hydrophobic and lipophilic; have the propensity to enter the gas phase under environmental temperatures and are subject to long-range transport; and (POPs) are globally distributed and even found in pristine environments such as the Arctic where they have never been used. The combination of their resistance to metabolism and lipophilicity means that they will bioaccumulate and be transported through food chains. Animal and human studies link a wide variety of health problems to exposure to POPs, such as reproductive abnormalities, birth defects, immune system dysfunction, neurological defects and cancer [1–3].

These chemicals have received intense international attention in recent years because of their ubiquity, persistence, high bioaccumulation potential and harmful biological effects. Under the Stockholm Convention on POPs (see Chapter 1), 12 chlorinated chemical substances have been banned or severely restricted. These include dioxins and furans (polychlorinated dibenzo-*p*-dioxins and polychlorinated dibenzofurans, PCDD/Fs),

polychlorinated biphenyls (PCBs), hexachlorobenzene (HCB) and several organochlorines used as pesticides: dichlorodiphenyl-trichloroethane (DDT), chlordane (CHLs), toxaphene, dieldrin, aldrin, endrin, heptachlor and mirex. These have been often referred to as 'legacy' POPs because of their long history of use and release into the environment. There are, however, numerous other POPs that are also environmental contaminants and are of great concern. Some of them are both persistent and toxic, and still in widespread production and use in both industrialized and less industrialized countries. These are often referred to as 'emerging' POPs. 'Emerging' POPs constitute those pollutants that have been recently discovered in the environment and are known or suspected to cause adverse effects in humans and wildlife. Examples of 'emerging' POPs in developing countries include several types of brominated flame retardants (BFRs) (see Chapter 2) such as polybrominated diphenyl ethers (PBDEs), perfluorinated compounds (see Chapter 3) and polychlorinated naphthalenes (PCNs).

Reports on the levels of POPs in the global environment indicate that emission sources of a number of 'legacy' POPs (such as DDT and HCHs) in the last 20 years have shifted from industrialized countries to developing countries in tropical and subtropical regions including India and China owing to late production bans or ongoing use, both legally and illegally, in agriculture [4, 5]. Also, as a result of recent changes in global trade, there has been a shift in the manufacture of goods to developing countries with cheap labor costs and weaker environmental laws. This shift in the industrial manufacturing of goods will also have implications for the global dispersal of 'emerging' POPs like PBDEs [4–6].

Exposure to POPs comes mainly from the consumption of food, especially meat, fish and dairy products. However, due to the ability of POPs to travel long-range, the POPs found in food do not always come from industries located near the farms where the food was produced or from the pesticides used on these farms. Instead, POPs cross international borders, moving thousands of miles in the air or water before entering a point source. This is why an international treaty to eliminate POPs is so important.

This chapter provides an overview of the status of POPs contamination in developing countries. It discusses the important classes of POPs in developing countries, including their current and past sources, environmental distribution and temporal trends, and examines the problems faced by developing countries with the effective management of POPs.

5.2 Sources of POPs in Developing Countries

Organochlorine pesticides used in agriculture and pest control, industrial chemicals like PCBs present in capacitors and transformers, unintentionally produced compounds such as polycyclic aromatic hydrocarbons (PAHs), dioxins and furans, and PBDEs, which are used as flame retardants in consumer products, are the main POP chemicals with significant sources in developing countries. PBDEs are 'emerging' POPs whose levels have the potential to increase in developing countries over time as a result of the current trend in the shift of the manufacturing base to developing countries [4] and the problem of dumping of e-wastes containing flame retardants in poorer developing countries [7–10]. Similarly, for perfluorinated compounds, their use in fire fighting foams might make them significant POPs in developing countries. Although often not included in the category of POPs, PAHs are considered so by some researchers. PAHs have many natural sources, but in developing countries the most important anthropogenic sources are vehicles and combustion of firewood for cooking. This section will examine the sources of the most important POPs in developing countries.

5.2.1 Summary of the Main POP Chemicals

5.2.1.1 Organochlorine Pesticides

Organochlorine (OC) pesticides constitute the major POPs in most developing countries around the world. They include DDTs, HCHs, chlordanes, toxaphene, dieldrin, aldrin, HCB, and newer ones not currently on the Stockholm Convention list (e.g. endosulfans). OC pesticides are released into the atmosphere by spray drift, post-application volatilization and wind erosion of soils. These emissions are influenced by numerous physical and chemical factors [11]. Although the use of many organochlorine pesticides was banned in North America, most of Europe and other industrialized countries during the 1970s and 1980s, they continued to be used in many developing countries in agriculture and in public health [12–15]. Some of the pesticides were even being manufactured as recently as the late 1990s in some Asian countries [16]. Well into the 1990s, for example, usage of technical HCH continued in India, Vietnam and other isolated parts of the world [17]. Most countries have made the switch to γ -HCH (lindane), although it is believed there are areas still using technical HCH, including India, Central America and parts of Asia [18]. Restricted use of DDTs for public health purposes is allowed under the Stockholm Convention, although it is suspected that there is ongoing use in agriculture in some developing countries.

As pointed out above, these pesticides are generally not produced in most of the developing countries except mainly in India and China. Developing countries are therefore net importers of these compounds. Over the past several decades many developing countries received thousands of tons of pesticides as donations, mostly from developed countries, to enhance food production and for the control of mosquitoes, flies and lice that spread malaria, typhoid fever and cholera. Although well-intentioned, in many cases the pesticide donations exceeded the true need of the countries. Pesticides therefore constitute the major source of POPs in developing countries, particularly sub-Saharan Africa, Asia and Latin America. There is a lack of precise figures on quantities of pesticides still held in many developing countries, but the Food and Agriculture Organization (FAO) of the United Nations estimates that there are around 500 000 tonnes of obsolete pesticide stocks in developing countries [19, 20]. The FAO has documented sites in developing countries where stockpiles are held in the open for prolonged periods of time, leading to the uncontrolled release of these chemicals to air and contamination of land and water resources. It is estimated that probably up to 120 000 tonnes are held on the African continent alone [21] and are present in virtually every country on the continent. Stockpiles in Asia are currently recorded at 6000 tonnes, a figure that does not include China, where the problem of pesticide waste is believed to be widespread. In the Middle East and Latin America together, around 10 000 tonnes have been declared. Stockpiles have also been reported for some Eastern European countries. For example, it is estimated that the Ukraine has around 19 500 tonnes of ageing chemicals, Macedonia 10 000 tonnes, Poland 15 000 tonnes and Moldova 6600 tonnes [21]. The condition of obsolete pesticide stockpiles varies from well-stored products that can still be used in the field to products that have leaked from corroded steel drums and other containers into the soil. The waste sites contain some of the most dangerous insecticides like aldrin, chlordane, DDT, dieldrin, endrin, heptachlor and organophosphates. It is estimated that about 30% of the known obsolete stockpiles are those currently targeted by the Stockholm Convention. Most of these pesticide stocks held in developing countries are obsolete for one or more of several reasons. These include: being banned while in storage; substandard storage and poor management of stockpiles; overstocking of products as a result of poor

assessment of requirements; strategic stockpiling in anticipation of pest incidence; purchase of inappropriate formulations; poor quality of pesticides and lack of analytical facilities; excessive donations and poor coordination among aid agencies; changes in national policy; and aggressive sales promotions by the pesticide industry [15, 20, 22].

5.2.1.2 Polychlorinated Biphenyls

Polychlorinated biphenyls (PCBs) are a class of chlorinated hydrocarbons consisting of 209 compounds ranging from three monochlorinated isomers to the fully chlorinated deca-chlorobiphenyl isomer. PCBs were first manufactured in 1929 for industrial use. Because of their properties (e.g. high chemical and thermal stability, electrical resistance, low or no flammability, high permittivity), PCBs have been used extensively as cooling liquids in transformers, dielectric liquids in capacitors, lubricating fluids, sealing liquids, adhesives, plasticisers, fire-resistant hydraulic fluids in mining equipment and vacuum pumps, fire-proofing agents, inks and paints, etc. [23, 24].

China is the only developing country known to have manufactured PCBs for its own use. The other countries known to have manufactured PCBs include Austria, Japan, Italy, Czechoslovakia (now Czech Republic), France, Germany, Spain, United Kingdom, United States and the Russian Federation. Breivik *et al.* [25] provided updated global production, consumption and emission information for PCBs. Of the 1.324 million tonnes of PCBs produced globally, only 0.6% was produced in developing countries [26]. It is estimated that the total consumption of PCBs in non-OECD (Organization for Economic Co-operation and Development) countries amounted to 11.2% (148 kt) of the global production of PCBs [25]. The global estimates suggest that the bulk of the PCBs was used in the northern hemisphere between latitudes 40° and 60° N (Figure 5.1). Recent surveys of soil [27] have shown that the latitudinal distribution of PCBs is similar to the production and use information given above.

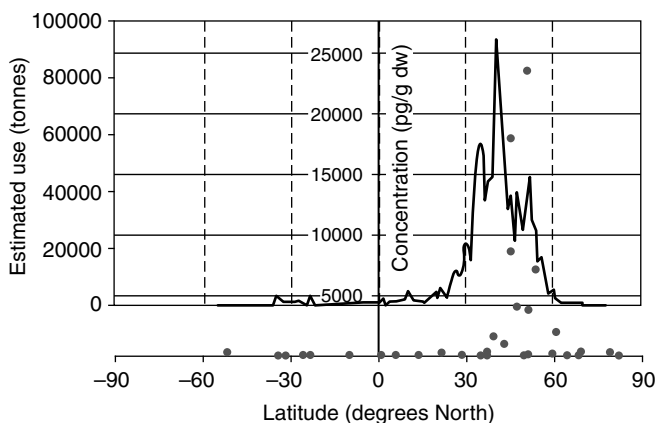

Figure 5.1 PCB concentration in background soils across the globe, including the estimated usage of PCB. (Reproduced with permission from *Environmental Science and Technology, Global Distribution and Budget of PCBs and HCB in Processes*, by S. N. Meijer, W. A. Ockenden *et al.*, 37(4), 667–672. Copyright (2003) American Chemical Society)

Many of the countries that formerly produced PCBs, except Russia, ceased production in the 1970s; however, PCBs remain in the environment for decades, where they are available for uptake and subsequent bioaccumulation in organisms. Before their ban PCBs had entered the environment through point and diffuse sources, such as from landfill sites, accidental spillages/releases during commercial use of electrical equipment and transformer and capacitor fires, incineration of PCB waste, etc. [24, 28, 29]. Leakage from old equipment, building materials, stockpiles and landfill sites continue to supply the environment. In addition, some production has been reported for certain countries with economies in transition [30, 31].

The use of PCBs in electrical transformers is the single largest source of PCBs in the vast majority of developing countries. In Vietnam, for example, about 2700–3000 tonnes of oil containing PCBs were imported from the former USSR, China and Romania [32]. Very little is known about the exact quantities of PCBs in most developing countries since no inventories exist for these compounds in most countries. Tentative estimates from South America indicate that Brazil has 130 000 tonnes, Chile 700 tonnes, Peru 1000 tonnes and Uruguay 81 tonnes of PCB-containing oils [21]. National inventories of PCBs are currently being generated by most developing countries in fulfillment of their obligations in the drafting of national implementation plans under the Stockholm Convention. One such survey carried out in the Philippines found that significant quantities of PCBs were present mainly in electrical equipments. The inventory revealed that 2089 tonnes of PCB oils were present in electrical transformers, capacitors and circuit breakers [14]. It was also revealed that there were approximately 498 tonnes of PCB oil in addition to a further 1903 tonnes suspected of containing PCBs. This example illustrates the vast quantities of stockpiles of POPs held by some developing countries, most of which lack the technical expertise to dispose safely of these chemicals.

In developing countries, additional sources of PCBs may come from the illegal dumping of toxic wastes containing these chemicals. In 1987, for example, an Italian company shipped and dumped illegally 8000 drums of PCBs in a small town, Koko, in the Nigerian Delta [33]. The dumping of hazardous waste in developing countries has been going on for years and is often shrouded in secrecy on the part of both the exporter and destination country in contravention of the Basel Convention [7, 22, 33–35].

Most developing countries are located in the tropical belt characterized by high temperatures and heavy rainfall. These climatic conditions mean that chemicals released in developing countries will volatilize and be transported to colder regions of the world [24, 29, 36]. This means that developing countries may continue to act as potential sources of POPs for many more years despite the bans on the use of these compounds in industrialized countries. The decreases in global levels in POP contamination can only be maintained if developing countries receive the help required to manage their stockpiles.

5.2.1.3 Polychlorinated Dibenzo-p-dioxins and Polychlorinated Dibenzofurans

Dioxins and furans are planar tricyclic compounds that have very similar chemical structures and properties. They may contain between 1 and 8 chlorine atoms; dioxins have 75 possible positional isomers and furans have 135 positional isomers. They are generally highly insoluble in water, lipophilic and very persistent. Neither dioxins nor furans are

produced commercially, and they have no known use. They are by-products resulting from the production of other chemicals and may be present as impurities in the end-product or released into the air [37–39]. Dioxins may be released into the environment through the production of pesticides and other chlorinated substances. Both dioxins and furans are related to a variety of incineration reactions, combustion and the synthesis and use of a variety of chemical products. They have been detected in emissions from the incineration of hospital waste, municipal waste, hazardous waste, car emissions and the incineration of coal, peat and wood. Significant sources of dioxins/furans include smelting, cement kilns, pulp and paper industries, electrical power generation, fuel burning (including diesel fuel and fuel for agriculture and home heating) and tobacco smoke [37, 39, 40]. Of the 210 dioxins and furans, 17 contribute most significantly to the toxicity of complex mixtures. Dioxins/furans are released into the environment mostly in air. The prevailing hypothesis is that most exposure of humans to dioxins/furans is via diet, with atmospheric deposition being the mechanism by which they enter the food chains and human diet [41–43].

Important sources of dioxins in the vast majority of developing countries are from waste incineration [39, 44], domestic burning [39], forest clearance for agriculture by the slash and burn technique [45, 46] and vehicular emissions due to weak emission control regulations [37–39]. In China, India, some Middle Eastern countries and South America, some municipal, industrial and hospital wastes are disposed of by incineration in small plants. This and other traditional sources of dioxins are also important in these countries. An additional source of dioxins in some developing countries is from the production and use of the sodium salt of pentachlorophenol [47, 49]. Although banned in many developed countries, this pesticide is used currently in China and possibly some African countries to control schistosomiasis [49] and as a wood preservative for making sleepers for railways. High levels of dioxins have been reported in areas where this pesticide was used, e.g. in China [50–52].

A legacy of the use of an estimated 600 kg of the herbicide Agent Orange during the conflict in Vietnam has been the contamination of soil, rivers, sediment and biota with dioxins [53, 54]. Hot spots of contaminated soils in the Aluoi Valley and other former US bases where the pesticides were stored have recently been identified [53]. These sites have considerably higher dioxin levels compared with regions where dioxins were aerially sprayed. These sites, if not cleaned up, will be a continued source of dioxins to the local environment for the foreseeable future.

5.2.1.4 Hexachlorobenzene (HCB)

HCB was used as an agricultural fungicide up to the 1970s but its use is now believed to be discontinued [55]. However, its continuing major source is as a contaminant in a range of chlorinated products, including pesticides such as the fungicide pentachloronitrobenzene (PCNB) and solvents, and in a wide variety of chemical manufacturing processes [55]. It is also a common constituent of flue gases, possibly originating from the combustion of chlorine-containing materials, as well as a product of incomplete combustion [55, 56]. HCB has been predicted to have an atmospheric characteristic travel distance (CTD) of ~100 000 km [57] because of its volatility and persistence. Thus it is distributed uniformly in the atmosphere. Bailey [56] assembled information from a variety of sources to give a picture of global HCB emissions in the mid-1990s. He suggested that no single overwhelming source dominated but, rather, emissions resulted from (largely past) pesticide applications,

manufacturing and combustion. It was estimated that the current global emission of HCB is 12–92 tonnes/year [56].

HCB has been detected in the environment in some studies carried out in developing countries. Its major source is likely to be combustion processes, especially open combustion of landfills containing chlorinated products.

5.2.1.5 Perfluorinated Compounds (see also Chapter 3)

Perfluorinated Compounds (PFCs) constitute another important class of chemicals that have recently been identified in the environment. They are used in fire fighting applications, herbicide and insecticide formulations, cosmetics, greases and lubricants, paints, polishes and adhesives [58, 59]. Perfluorooctanesulfonate (PFOS) is considered to be the terminal degradation product of many of the commercially used PFCs and is the predominant perfluorinated acid found in most environments that have been studied. In addition to PFOS, there are other commercially used PFCs that can occur in the environment, including perfluorooctanoic acid (PFOA), perfluorooctane sulfonamide (PFOSA), perfluorohexanesulfonate (PFHS), perfluorobutanesulfonate (PFBS) and perfluorononanoic acid (PFNA) [60]. The global production of sulfonyl-based fluorochemicals in 2000 was estimated at 2.9 million kg [61]. PFOS has been shown to be ubiquitous in the global environment, including water [62], fish [61, 63], birds [64], and marine and terrestrial mammals [63]. Distribution patterns are thought to be similar to those of “legacy” POPs and, like “legacy” POPs, the levels in remote locations are generally several times lower than those found in urbanized and industrialized regions.

As is the case with most POP chemicals, most of the studies reported in the scientific literature so far are from developed countries. The sources of PFOS in developing countries are poorly understood and there are no inventories of quantities imported or used in these countries. Releases of PFOS may be linked to its use in fire fighting applications, accidental releases or disposal of items to which they were added during their manufacture, such as rugs, carpets, fabrics, leather articles, paper packaging and photographic material. Landfilling of PFOS-containing material will result in releases of PFOS into air, ground or surface waters.

5.2.1.6 Polychlorinated Naphthalenes (PCNs)

PCNs are a group of compounds with similar physical chemical properties to PCBs [65]. They contain one to eight chlorine atoms per naphthalene molecule and form a complex mixture of 75 congeners. They were produced before PCBs but were replaced by the latter compounds after incidents of worker-related toxicity [66]. Although the use of PCNs has declined in the past few decades, they are not prohibited in most countries and still occur in many PCB-like applications such as capacitor fluids, engine oil additives and electrical insulators [67].

PCNs have also been found in incinerator and metal refining emissions, as contaminants in PCB formulations [68, 69] and have also been detected in air [65, 66, 70]. Other sources of PCNs to the atmosphere include chlor-alkali processes and thermal processes [71], particularly emissions from municipal solid waste incinerators (MSWI) [72]. In developing countries, sources of PCNs are likely to be incinerators. Jaward *et al.* [70] measured significant levels of PCNs in air off the coast of West Africa and South Africa, indicating that this class of compounds cannot be neglected in developing countries. It also indicates that

there is definitely a need for monitoring in developing countries to determine typical levels and sources.

Despite much lower production than PCBs, PCNs are now found to be widespread in the environment, having been detected in biological samples from even remote regions of the Arctic [73, 74]. Consumption of contaminated fish is considered to be an important route of exposure of humans to PCNs. High concentrations of penta- and hexachloronaphthalenes in human blood plasma have been correlated with fish consumption [75].

5.2.1.7 Polybrominated Diphenyl Ethers (PBDEs) (see also Chapter 2)

PBDEs are a class of chemicals widely used as flame retardants in a variety of applications. They are ubiquitous in the environment and have been detected in various environmental media including air [76, 77], water [78], biota [1, 79], soil [80], sediments [81, 82], house dust [83, 84], cars [85], humans [86] and sewage sludge [87]. PBDEs are similar in molecular structure to several well-known POPs such as PCBs and dioxins/furans. They have very similar physicochemical properties and, like these compounds, PBDEs are of environmental concern because of their high lipophilicity, persistence and resistance to degradation [88–90].

As PBDE concentrations have increased exponentially in very remote regions [91] and because of their similarity to ‘legacy’ POPs in structure, bioaccumulative and toxicological properties, concern over their use has grown in recent years [3, 92–94]. Levels of PBDEs appear to be rising rapidly in human tissues, as evidenced by studies of human breast milk [95–98]. Although PBDEs and other brominated flame retardants (BFRs) are not included on the Stockholm list of compounds targeted for elimination, both the penta- and the octa-mix PBDE formulations are being considered for inclusion (see Chapter 1).

The estimated global production of PBDEs, one of the most widely used BFRs, was estimated to be 40 000 metric tonnes in 1990 [89, 99]. Israel is the only known developing country where PBDEs are manufactured. PBDEs can enter the environment through emissions from the manufacturing process, volatilization from products containing them, through waste recycling and leaching from landfill and dumpsites. It is difficult to estimate the quantities of PBDEs used or present in developing countries because the compounds are imported primarily as additives in consumer products. Three different formulations of PBDEs are available commercially: penta-, octa- and deca-PBDE. The penta-product is added principally to polyurethane foams that are used in household furniture, and is also used in carpet underlay and on bedding. The octa-product is used in hard casings of computers, cell phones, electronic games, televisions and home appliances. The deca-product is added to high-impact polystyrene for television sets, computers and other electronic housings and circuit boards [89, 90, 99].

As is the case with “legacy” POPs, source inventories for environmental releases of PBDEs are not available. However, it is thought that the main source of PBDEs in the vast majority of developing countries is from the recycling of electronic goods, the so-called e-waste, which is increasingly becoming a profitable enterprise in developing countries, particularly China, India, Pakistan, Vietnam and several African countries [7–10]. E-waste refers to end-of-life electronic products including computers, printers, photocopying machines, television sets, mobile phones and electrical cables [7, 10]. It is estimated that 50 million tonnes of e-wastes are produced annually in the world and are by far the fastest growing waste streams in developed countries [100]. It is estimated that about 80% of all

computer e-waste is being exported to Asia, with 90% of these exports ending up in China for recycling. This is because of lower environmental and working standards in these countries. The technologies adopted in these countries for recycling e-wastes are often environmentally unfriendly, hazardous and primitive. It includes stripping of metals in open-pit acid baths to recover gold and other metals; removing electronic components from printed circuit boards by heating over a grill using honeycombed coal blocks as fuel; chipping and melting plastics without proper ventilation; burning cables for recovering metals and burning unwanted materials in open air; disposing of unsalvageable materials in fields and riverbanks; and dismantling electronic equipment [7, 10]. Flame retardants in these electronics can be released during the recycling process. Kemmlein, Haln and Jann [101] measured emission rates of PBDEs from electronic devices and estimated that PBDEs were emitted at a rate of between 0.2 and 6.6 ng/m²h at 60 °C with emission rates increasing 500-fold at higher temperatures. Incineration of e-waste containing PBDEs is also considered to contribute significant amounts of PBDEs and toxic dioxins into the environment in developing countries. A recent study by Leung *et al.* [100] found extremely high PBDE concentrations in soil from a former electronic recycling site in Southern China (33 000–97 400 ng/g dry weight (d.w.)), an acid leaching site (2720–4250 ng/g d.w.) and a printer roller dump site (593–2890 ng/g d.w.), all of which illustrate the potential problems of contamination associated with e-waste recycling. These concentrations at these sites are 4–8 times higher than those in soils from a polyurethane foam manufacturing site in the United States, which uses penta-BDE as a flame retardant, whereas the concentrations in soil at the printer roller site is reported to be 131 times higher than concentrations at the highest background soil concentrations in the United Kingdom [100].

5.2.2 Municipal Landfill Sites as Potential Sources of POPs to the Environment

Solid waste management is a major challenge faced by developing countries. In the absence of advanced solid waste management technologies, municipal waste is often dumped in the open at landfill sites, often within close proximity to residential areas. These dumpsites are increasingly being recognized as potential sources of toxic chemicals including dioxins, PBDEs, PCBs, and in some cases pesticides and PCNs. Uncontrolled combustion of solid waste particularly of cables and other electronic equipments, is a crude method used by people scavenging at these sites to recover metals. Low-level combustion of waste at these sites is favorable to the formation of dioxins and related compounds.

A recent soil survey from dumpsites and background sites from Cambodia, India, Vietnam and the Philippines showed that residue levels of dioxins/furans and co-planer PCBs in dumpsite soils were significantly higher than background soils, suggesting that dumpsites are potential sources of these compounds [102, 103]. Mean concentrations of dioxins/furans and co-planar PCBs were highest in the Philippines, followed by soils from Vietnam, Cambodia and India (see Table 5.1). The concentrations in soil samples from the Philippines are even higher than values that have been reported in the literature for dioxin contaminated sites around the world [102]. While these landfill sites act as emission sources for dioxins/furans and related compounds, they might also be a potentially important reservoir of other POPs and heavy metals.

Since these landfill sites are usually located near human habitats, the local populations, particularly those scavenging through the garbage for 'valuables', are potentially exposed to

Table 5.1 Comparison of concentrations of POPs (ng/g d.w.) in soils from municipal dumpsites and background sites from some developing countries. (After Minh et al. [102])

Country	Year	Σ PCDD/F		Co-planar PCBs		DDT ^a		HCHs		CHLs		HCB	
		DS	BS	DS	BS	DS	BS	DS	BS	DS	BS	DS	BS
				DS	BS								
Philippines	1999	61	0.057	41.5	7.6								
Cambodia	1999	30	0.13	7.6	0.011								
India	2000	7.4	0.033	6.6	0.028	24	0.08	30	0.06	6.4	0.06	0.2	<0.02
Hanoi, Vietnam	2000	6.1	0.37	2.6	0.13	21	6	0.75	0.35	0.3	<0.03	0.5	0.07
Hochiminh, Vietnam	2002	0.37	0.19	0.91	0.16	23	5.5	0.56	0.54	1.2	0.2	0.12	0.15

^aData from Minh et al. (Conference paper).

DS = dumpsite, BS = background site.

high concentrations of toxic chemicals, with serious health implications. Concentrations of dioxins/furans have indeed been shown to be significantly higher in hair samples of people scavenging at a dumpsite in Egypt [44]. Recently, a series of studies by Kunisue and coworkers [103–105] have shown elevated levels of dioxins/furans, PCBs and OC pesticides, such as DDT, HCHs, CHLs and HCB, in human breast milk from residents around landfill sites in India, Cambodia, Vietnam, Malaysia, China, Philippines and Indonesia. Another study of milk from cows and buffaloes indicated a similar pattern, with significantly higher concentrations of dioxins/furans and related POPs in animals grazing on and close to the dumpsites compared to those from remote locations [103–105]. The wider implication of these studies is that landfill sites in developing countries may continue to act as sources of POPs (especially chemicals like flame retardants contained in electronic wastes now shipped to developing countries) to the global environment.

5.2.3 Dumping of Toxic Wastes as a Source of POPs in Developing Countries

The practice of illegal shipment and dumping of hazardous wastes to developing countries has gone on for several decades now [22, 33–35]. Uncontrolled dumping of toxic wastes in developing countries can be traced back to the early 1970s [35]. By using developing countries as disposal sites, industrialized countries minimize the costs of disposing or recycling these by-products. The illegal dumping of 8000 drums of PCB-containing waste in a small town in the Niger Delta in Nigeria by an Italian company in 1987 is a classic example of the unique contamination problem faced by poor African and other developing countries around the world in dealing with environmental contamination of POPs [33]. Improper waste disposal can result in the release of hazardous chemicals into the environment. Chemicals such as PCBs can seep from waste sites into soil and water.

As discussed previously, industrialized countries are increasingly shipping electronic items nearing the end of their useful life under the guise of ‘bridging the digital divide’ [7–10]. Most of the growth of the IT industry in Africa and Eastern Europe is fuelled by the importation of ‘hand-me-down’ used equipment from rich, developed countries. Developing countries have now become dumping sites of tonnes of used computers, fax machines,

cell phones and other electronic items. It is reported that over 75% of the electronics shipped to developing countries is 'junk' which will end up at landfill sites or being burnt. As discussed in the previous section on electronic waste, brominated flame retardants and other toxic chemicals are present in electronic equipment, which will be released and contaminate the environment or groundwater from either landfill sites or during their recycling.

5.3 Levels of POPs in Developing Countries

A wide range of biotic and abiotic matrices have been used to measure the concentrations of POPs in the environment. These include air, sediment, water, soils, human tissue (blood, adipose tissue), fish, birds, eggs, plants and food. There is a huge amount of data on levels of 'legacy' POPs, in particular, in different regions of the world. A detailed compilation of data on POPs has been undertaken recently by UNEP chemicals [21] and released as a global report (<http://www.chem.unep.ch/pts>). The report showed clearly that the southern hemisphere is underrepresented in terms of information and that huge data gaps exist for most POPs in developing countries. Other excellent reviews have been carried out on levels of 'legacy' and 'emerging' POPs, particularly in the Asia Pacific region [5, 6, 14, 106–109] and Latin America [15] but also for Egypt [13]. Most of the high-quality data that exists for developing countries is based on work carried out in Asia and South America with only a few studies in the Middle East and Africa. The data in most developing countries are often patchy since most of the studies are one-off exercises. Most of these studies are from individual studies and in most cases data on POPs in some developing countries are not published in the scientific literature. Long-term monitoring data from which to interpret trends in the environment is often unavailable for most developing countries. This can be blamed partially on financial constraints as well as a lack of trained scientists and advanced analytical facilities needed for the analysis of POPs. The comparison of data that is reported in the literature from developing countries poses challenges due to differences in analytical methodologies used in the studies and reporting protocols. For example, PCBs are reported as Aroclor equivalents in some studies whereas recent studies quantify individual congeners. Advances in analytical methods also make data comparisons extremely difficult between different studies. Another problem relates to differences in reporting protocols in various studies in the literature. For example, the concentration of POPs in biota is reported on a wet weight, dry weight or lipid weight basis; concentrations are also often reported for whole organisms or for specific organs, and there are also differences in processing the samples for analyses. These differences often mean that data reported in the literature cannot be used easily to compare levels on a regional basis. The ideal approach to understanding spatial distributions of POPs is having a network on a regional or global basis where samples are collected and analyzed using the same protocols, either in the same laboratory or in several laboratories, using similar analytical methods following interlaboratory comparisons. There are a few large-scale studies in the developing world that were carried out in the same laboratory using the same sampling and analytical protocols. Examples of such good practice include the work of Pozo *et al.* [110] and Iwata *et al.* [111, 112] on air, that by Kalantzi on butter [113], the 'Mussel Watch' programs [114–116] and soil [27], among others. A selection of studies will be discussed in the following section to highlight the differences in the concentrations of POPs in different developing countries and to relate

these differences with known factors that control concentrations such as sources, emission characteristics, and the fate and transportation of these chemicals. Several environmental matrices have been recommended as being suitable for assessing the global distribution of POPs. These include air, bivalves and other biota, and human milk.

5.3.1 Air

Because air responds rapidly to changes in primary emissions of POPs, it has been suggested as a very useful matrix for regional and global monitoring studies. The most comprehensive analysis to date on the global distribution of organochlorine pesticides and PBDEs is the Global Atmospheric Passive Samplers (GAPS) study [110]. The GAPS study used polyurethane foam disks to passively sample air in 47 countries on seven continents, covering parts of the world where no reliable data existed. In general, the findings from this study showed levels consistent with usage patterns around the globe.

The highest concentrations of hexachlorocyclohexane (HCH) in the GAPS study were measured in developing countries where they were heavily used. Concentrations of α -HCH, the main component of technical HCH used as a pesticide in the past, were highest in South Africa (117 pg/m³) and Harbin and Chengdu in China (132 pg/m³ and 145 pg/m³, respectively) (Figure 5.2(a)). The γ -isomer (lindane), which replaced the technical HCH, was highest in Africa and Asia, with the highest recorded concentrations encountered in Chengdu, China (68 pg/m³), and De Aar, South Africa (67 pg/m³) (Figure 5.2(b)). The distribution of endosulfan, a current-use pesticide, also showed higher concentrations in developing countries (Figure 5.2(c)), primarily in Africa and South America. Very high concentrations were encountered in Bahia Blanca, Argentina and Las Palmas on the Canary Islands. The distribution of chordanes also shows that the levels in developing countries, particularly in the Philippines (338 pg/m³), were higher than in most industrialized countries (Figure 5.2(d)). The distribution of heptachlor and heptachlor epoxide also showed elevated levels in developing countries, particularly in Bahia Blanca (Argentina), Costa Rica and the Philippines. A similar distribution pattern was observed for dieldrin and DDT. *p,p'*-DDT, the dominant component of DDT, was detected at three sites, with the highest concentration (190 pg/m³) measured in Manila, in the Philippines. In general, the distribution of pesticides in the GAPS study reflected their use in agriculture and for pest/vector control, as exhibited clearly by the distribution pattern of endosulfan.

These results are in agreement with a regional study carried out recently in Mexico using a combination of passive samplers and high-volume samplers in a network of 14 sites [117]. DDTs ranged from 15 pg/m³ to 2360 pg/m³, with levels higher in southern Mexico, where DDTs were most heavily used in agriculture and for public health reasons. Similarly, the most elevated concentrations of endosulfan in air (26 765 pg/m³) were found in an agricultural area in north-west Mexico, near Mazatlan. The highest levels of toxaphene were found in Baja California, Mazatlan and Chiapas in Mexico, precisely the areas where this pesticide was used most heavily in agriculture in the recent past.

Profiles of toxaphene congeners indicated that the toxaphene in air in Mexico was mainly from soil emissions due to past usage. Similarly, a study carried out by Shen *et al.* [118] using passive samplers in a 40-site network in North America (including Mexico, Belize and Costa Rica) indicated higher levels of OC pesticides in areas of ongoing or past usage. Batterman *et al.* [119] recently reported on air concentrations of organochlorine pesticides

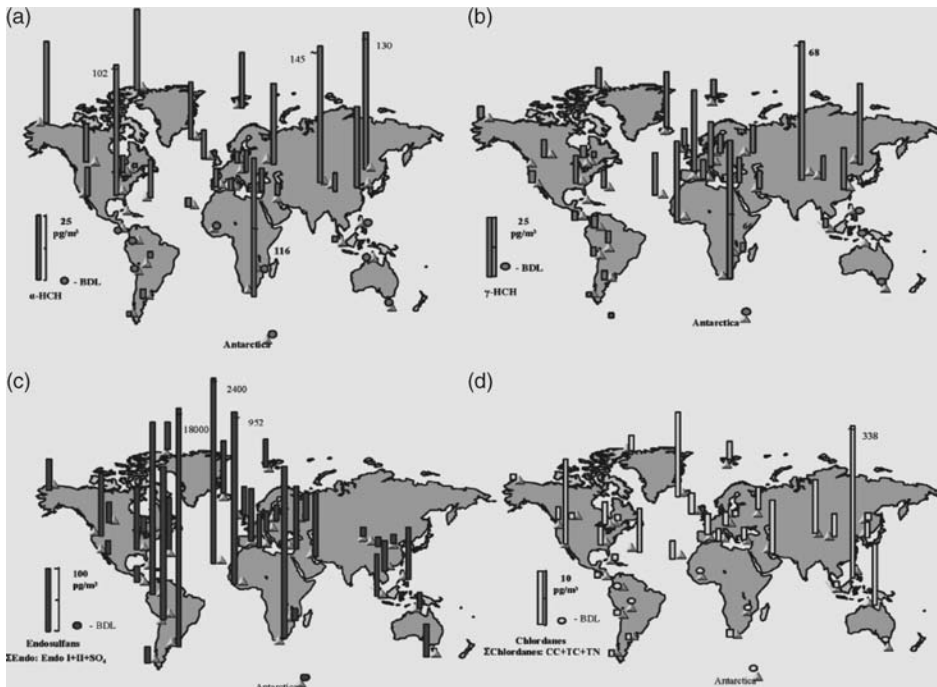

Figure 5.2 Air concentrations (pg/m^3) of α -HCH (hexachlorocyclohexane), γ -HCH, endosulfans (sum of endo I, endo II and endosulfan sulfate) and chlordanes (sum of trans-chlordane, cis-chlordane, and trans-nonachlor) between December 2004 and March 2005 at GAPS sites around the world. (Reproduced with permission from Environmental Science and Technology, *Toward a Global Network for Persistent Organic Pollutants in Air: Results from the GAPS Study*, by Karia Pozo, Tom Harner *et al.*, **40**(16), 4867–4873. Copyright (2006) American Chemical Society)

around Durban, South Africa. Average concentrations in pg/m^3 were: Σ DDTs \sim 78, lindane 133, α -HCH 1.60, HCB 4.50, Σ chlordanes 25.3, Σ toxaphenes 12 and aldrin 10.1.

PCB concentrations shown in Figure 5.3 show that PCB levels were generally higher in developed countries except for samples collected in Manila and South Africa. The highest concentration ($2800 \text{ pg}/\text{m}^3$) in this survey was surprisingly from the Manila site. This may be due to the site being an urban site reflecting emissions from the city. Using a different method of sampling (high volume air sampling), Iwata *et al.* in 1994 [111] reported a wide variation in the levels of PCBs in oceanic air between different locations in tropical Southeast Asia (74 – $4600 \text{ pg}/\text{m}^3$), although levels comparable to the GAPS study were observed over the whole region. The regional study carried out in Mexico also indicated low levels of PCBs, even in urban areas, in agreement with the GAPS study [117].

The spatial distribution of Σ PBDEs in the GAPS campaign described above appears to reflect patterns of usage (Figure 5.3) [110]. The levels were generally higher in North American samples. The second highest concentrations of PBDEs ($17 \text{ pg}/\text{m}^3$) was measured at a site in Kuwait. There are no known sources of PBDEs in Kuwait besides their presence in consumer products. However, PBDEs are manufactured in Israel by the Dead Sea

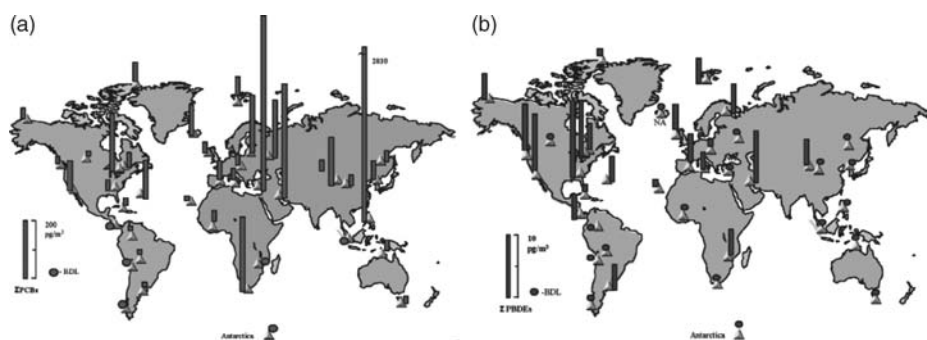

Figure 5.3 Air concentrations (pg/m^3) of (a) PCBs and (b) PBDEs between December 2004 and March 2005 at GAPS sites. (Reproduced with permission from *Environmental Science and Technology, Toward a Global Network for Persistent Organic Pollutants in Air: Results from the GAPS Study*, by Karia Pozo, Tom Harner et al., **40**(16), 4867–4873. Copyright (2006) American Chemical Society)

Bromine Company and releases that occur during the production of these chemicals may influence levels in the region. Relatively high concentrations were measured in the southern part of Africa, South America and China. These may reflect releases from e-waste recycling activities that are carried out in developing countries.

5.3.2 Butter

Butter has also been used effectively as a matrix for studying the distribution of POPs on a global scale. Butter offers an ‘indirect’ method of determining atmospheric concentrations of POPs in various parts of the world. The most significant attempt at a comparative assessment of levels of POPs on a global scale using butter as a matrix comes from the work of Kalantzi et al. [113]. Samples of butter were collected simultaneously from various parts of the world, including several developing countries, and analyzed by a standardized procedure in the same laboratory for organochlorine pesticides and PCBs. The concentrations for developing countries reported in the study (Table 5.2) reflect usage patterns around the globe. The highest concentration of DDT and HCHs from developing countries were in

Table 5.2 Global comparison of POPs concentrations (ng/g l.w. (lipid weight)) in butter from developing countries. (After Kalantzi et al. [113])

Country	PCBs	DDTs	HCHs	HCB
Brazil	1.06	4.25	2.33	0.52
India	4.51	248.88	222.76	0.63
Israel	3.57	20.89	3.59	1
Mexico	1.18	101.22	2.86	1.11
Philippines	0.52	71.29	0.91	0.92
South Africa	4.16	4.02	2.48	0.72
Thailand	1.21	3.95	2.49	0.83
Tunisia	11.81	7.8	6.41	2.34
UK	3.37	2.39	3.86	2.12
USA	2.25	23.61	1.33	0.9

samples collected from India followed by Mexico. Samples from the southern hemisphere contained consistently the lowest concentrations of PCBs, in line with observations from surface soils [27].

5.3.3 Sediments

Because of their hydrophobic nature, upon reaching aquatic environments, POPs are very quickly sequestered by organic-rich particles and delivered to the bottom sediments where they are ultimately buried. Sediments tend to integrate contaminants over long periods of time and are often the best matrix for assessing spatial and temporal concentrations of hydrophobic organic contaminants. Sediments are thought to act as the ultimate 'sink' of POPs, and sediment samples have been analyzed extensively in developing countries to understand historical and recent levels of pollution, especially along coastal areas affected by industrial developments. In Mexico, for example, several studies have documented OC pesticides and PAHs in sediments collected in primarily coastal lagoons [120]. Concentrations of OC pesticides in several developing countries are summarized in Table 5.3. Published studies [106, 121–124] were selected to highlight differences between various developing countries. It is evident that clear differences exist in levels in various countries, which appear to reflect usage patterns in these countries/regions.

The Regional Organization for the Protection of the Marine Environment (ROPME) carries out periodic sediment surveys in the Arabian Gulf. The results from these surveys show that distribution of OC pesticides was generally 'patchy' with hot spots of contamination. The highest concentrations in Arabian Gulf sediments were encountered in the Shatt Al-Arab River, which drains a heavily agricultural region in Southern Iraq. The concentrations of PCBs are generally less than 10 ng/g in sediments from the Arabian Gulf. The exceptions are patches of coastal sediments opposite marinas, harbours and industrial estates where concentrations range from 100 to 150 ng/g [126, 127].

5.3.4 Soils

Soils, particularly those with high organic carbon content like peat, are natural sinks for POPs. Compounds are delivered to soil from wet and dry atmospheric deposition, accidental spills, sewage sludge application to land and direct pesticide applications. Soil-bound POPs can be taken up by crops and by grazing animals and hence reach the human food chain. They may also be washed in run-off from the land into watercourses. In tropical and subtropical regions characterized by heavy rainfall, soil erosion can be severe and eroded soils may therefore cause significant pollution of waterways in tropical countries. The levels of POPs in 'background' soils, which receive chemicals solely from atmospheric deposition, vary depending on soil type and organic carbon content. Within a given geographical region, POP concentrations in 'background' soils have been shown to be higher in forested soils compared to those in grasslands.

The concentrations of POPs in soils in developing countries vary depending on the proximity to sources or history of pesticide use in the region. A comparative assessment of the concentrations of POPs in soils from developing countries is given in Table 5.4. A selection of published studies [106, 122, 128–135] from different developing countries were used to highlight differences brought about due to usage patterns in various countries.

Table 5.3 Comparison of concentrations (ng/g d.w.) of various POPs in sediments from various water bodies in developing countries

Country	Year	DDTs	HCHs	CHLs	PCBs	HCB	Aldrin	Endrin	Dieldrin	References
Iraq	1985	2000–7000						35 000–50 000	8000–40 000	[125]
Kuwait	1998	5.0–1400	82–115		1.2–98	15–3500	<d.l.–220	<d.l.–93	<d.l.–110	[148]
Saudi Arabia	1998	0.7–91	0.44–5.6		0.008–0.19	3.5–28		4.8–53	1–6.7	[148]
Iran	1997	2400–3400	51–230		0.62–0.65	210–810	14–59	23	56–59	[148]
Vietnam	1990	2.1–790	6.0–12		440–630					[122]
Ghana	2000	0.46	3.2			0.9				[123]
Honduras	1995–7	<d.l.	33 (α -HCH)	<d.l.				<d.l.	3	[135]
Vietnam	2002				144–370					
Vietnam	2003–4	0.01–110		0.004–1.9	0.039–9.2	<0.006–0.080				[106]
Singapore	2003	2.2–11.9	3.3–46.2	1.4–18.7	1.4–329.6					[124]
Korea	1997	0.2–80.2	<d.l.–1.3	<d.l.–1.7	1.2–41.4					[151]

d.l. = detection limit.

Table 5.4 Comparison of concentrations (ng/g d.w.) of various POPs in soils from various developing countries

Country	Year	Soil type	DDTs	HCHs	CHLs	PCBs	Endosulfans	References
Philippines	1994	Agricultural	1.2–200	0.1–5.2		<1		[128]
Philippines	1994	Dumpsite	50–1100	10–190		30–200		[128]
Indonesia	2003	Urban	25	29				[131]
India	2000	Dumpsite	24	30		180		[102]
India	2000	Rural	0.079	0.048		0.052		[102]
China	2000	Agricultural	68	16				[138]
Cambodia	2000	Dumpsite	350	1.7		140		[102]
Cambodia	2000	Rural	1.1	0.01		0.85		[102]
Vietnam	2000	Rural	35	2.1		12		[139]
Egypt	1996	Urban	1.4			2.3		[129]
Argentina	1996	Agricultural	30	21				[130]
Honduras	1995–7	Agricultural	~200–>2000		70–110			[135]
Costa Rica	2004	Background	~1.5	~0.14	<0.05			[133]
Ethiopia	2003–4	Agricultural	~60–~230	Nd–~9.4			~7.6–>1300	[134]
Nepal	2004	Variety						[132]

Recently, a survey has been carried out on the levels of DDTs and HCHs in differently cultivated and noncultivated soils from the Pearl River Delta (China) in 2000 [136]. The concentrations of DDTs ranged from 15 to 125 ng/g, while HCHs ranged from 2 to 30 ng/g in agricultural soils. In nonagricultural soils, mean DDT and HCH concentrations were 6.7 ng/g and 8.2 ng/g respectively. The highest DDT concentrations were measured on paddy fields used for rice cultivation. High concentrations of HCHs were detected in vegetable, banana, sugarcane and fruit plantation soils, as well as fish-pond causeway soils, suggesting its former use in agriculture or for the purposes of maintaining fish health.

A survey of soils from 224 sites in India used for the cultivation of cotton, wheat, rice and vegetables had DDT concentrations ranging from 5 to 49 ng/g [137]. In Cuba, DDT levels reported in soil samples from rice-producing fields ranged from 60 to 350 ng/g, whereas total insecticide concentrations (DDTs, heptachlor, lindane and metoxychlor) ranged from 10 to 840 ng/g. Very high concentrations of HCHs were reported in soil samples from Kazakhstan, ranging from 1000 to 1900 ng/g [21].

Soil samples from paddy fields, uplands and urban areas (gardens and roadsides) collected from Vietnam, Thailand and Taiwan show high levels of DDTs, HCHs and PCBs [122, 139, 140]. The DDT levels in soil samples from Vietnam were found to be highest, with a mean value of 110 ng/g, while the Taiwanese soils averaged 20 ng/g. HCH concentrations averaged 4.8 ng/g and 1.2 ng/g in Vietnamese and Taiwanese soils, respectively. Concentrations of PCBs were extremely high and averaged 95 ng/g in Taiwanese soil samples. Interestingly, relatively high concentrations of PCBs in rural cultivated-soil samples from Vietnam were measured (mean of 25 ng/g), probably suggesting PCB release from different kinds of weapons used during the Second Indochina War. Thailand recorded the lowest concentrations of these compounds [140]. A detailed study by Iwata *et al.* recorded high levels of HCB, HCHs, DDTs, PCBs and chlordanes in soils from the Lake Baikal region in Russia [141].

A recent study in southern Mexico [117] indicated that the POPs present in highest levels in soils were DDTs and toxaphene. Σ DDTs in soils ranged from 0.057 to 360 ng/g while toxaphene ranged from 0.066 to 69 ng/g.

5.3.5 Bivalves

Bivalves have been used extensively to monitor POPs in coastal marine ecosystems. Their restricted mobility and contact with substrate, resistance to stress, tolerance to a wide range of salinities and ability to accumulate a wide variety of contaminants makes them useful as monitors of local pollution [142]. Because they are sessile, the concentrations of POPs in their tissues, obtained through respiration and diet, should reflect the state of pollution within their immediate vicinity. They can, therefore, serve to identify point sources of pollutant inputs into coastal marine environments. The 'Mussel Watch' programmes, which examine the levels of POP compounds in bivalves around the world, offer another way of comparing data from different regions of the world as well as a way of investigating temporal trends in changes in POP contamination over the long term. There are 'Mussel Watch' monitoring programmes that have been on-going in Asia and South American countries for some time now [114–116]. The International Mussel Watch (IMW) Program, for example, was carried out at the behest of the United Nations Educational, Scientific and Cultural Organization (UNESCO), the Intergovernmental Oceanographic Commission and

the United Nations Environment Programme (UNEP), the Ocean and Coastal Areas Program, to assess the extent of chemical contamination, primarily in the equatorial and subequatorial areas of the southern hemisphere, with particular attention to coastal areas of developing countries.

A total of 76 sites were sampled in South America, Central America, the Caribbean and Mexico. Selection of sites included locations near known or suspected contamination sources in addition to noncontaminated sites. Analyses showed that concentrations of OC pesticides were not elevated for most of the stations and were similar to the range of concentrations found in the United States. Several stations near urban or agricultural areas in this region show elevated concentrations of one or more OC pesticides. Individual PCB concentrations were generally lower for the Latin America data set in comparison to the NOAA Mussel Watch data set for the US coast. PAH concentrations in the sample set were generally within the range of PAH concentrations found in the NOAA Mussel data set but with several locations exhibiting elevated concentrations (document available at http://ccma.nos.noaa.gov/stressors/pollution/assessments/as_intl_mw_study.html).

Monirith *et al.* [115] summarized results of surveys of mussels carried out between 1994 and 2001 from coastal waters of Cambodia, China, Hong Kong, India, Indonesia, Korea, Malaysia, Philippines, Singapore and Vietnam for OC pesticides and PCBs. The results are shown in Tables 5.5 and 5.6, together with studies from selected peer-reviewed literature [14, 107, 114, 115, 143–152] from other countries for comparison. The levels found in bivalves from various regions of the developing world reflect continued usage of these compounds for public health reasons and in pest control. For example, DDT levels are highest in mussel samples from the coastal waters of South China, Hong Kong and Vietnam. The composition of DDT in the samples from Asian countries showed a dominance of *p,p'*-DDT, suggesting the presence of current emission sources of DDT in Asian countries despite a ban on their continued usage in 1983. On the other hand, the highest concentrations of HCHs are for mussels from India, the world's largest consumer of technical HCHs [12, 17]. The agricultural use of technical HCH is banned in India but with exemptions allowed on public health grounds [153]. The highest concentrations of PCBs were found in samples from the Philippines and Vietnam, consistent with the presence of large stockpiles of these compounds present in electrical transformers, capacitors and circuit breakers, as revealed by recent surveys conducted in these countries during the drafting of national implementation plans under the Stockholm Convention. The concentrations of CHLs were higher in mussels from coastal waters from China, Hong Kong, Malaysia, Singapore and the Philippines, which are linked to their use in the fishing industry. The only country with elevated levels of HCB in mussel samples is China.

The levels are similar to samples from most other developing countries. In general, the distribution patterns of POPs in mussels from developing countries appear to mirror their usage patterns in these countries.

5.3.6 Breast Milk

Humans are exposed to pollutants via inhalation, dermal uptake and dietary and nondietary ingestion. In fact, human exposure begins from the womb and continues until death. Since POPs are lipophilic contaminants, they tend to accumulate in large quantities in lipid rich tissues. Their accumulation in human milk has received considerable attention because of

Table 5.5 Comparison of PCBs and organochlorine pesticides (ng/g wet weight) in bivalve molluscs

Location	Year	Species	PCBs	DDTs	CHLs	HCHs	HCB	Reference
Guanabara Bay, Brazil	1986–1993	<i>Mytilus edulis</i>	34					[114]
Guanabara Bay, Brazil	1996	<i>Perna veridis</i>		1.1–10		0.1–0.9	<0.01–0.7	[143]
Cambodia	1998	<i>Perna veridis</i>	<0.50–5.1	0.1–0.2	<0.01	<0.01	<0.01–0.03	[154]
China	1999–2001	<i>Perna veridis</i>	0.3–3.1	58–630	1.0–10	0.10–0.60	<0.01–0.50	[154]
China	1999	<i>Perna veridis</i>		151–200				[145]
China	1994–1995	<i>Perna veridis</i>	0.52–10	240–310		0.70–5.4		[151]
India	1998	<i>Perna veridis</i>	0.2–11	0.6–15	<0.01–3.3	0.2–7.7	<0.01–0.3	[154]
India	1994–1995	<i>Perna veridis</i>	0.31–15	0.9–40	<0.01–2.0	1.5–12	<0.01–0.4	[147]
India	1998–1999	<i>Perna veridis</i>	0.7–7.1	3.0–40		4.3–16		[144]
Indonesia	1998	<i>Perna veridis</i>	0.1–2.7	0.1–3.1	<0.01–0.3	<0.01–0.1	<0.01–0.03	[154]
Isla de Aserradores, Nicaragua	1986–1993	<i>Mytilus edulis</i>		32	2			[114]
Malaysia	1998	<i>Perna veridis</i>	<0.05–5.1	0.06–0.8	0.1–9.6	<0.01–0.20	<0.01–0.60	[154]
Puerto Madero, Mexico	1986–1993	<i>Mytilus edulis</i>		21				[114]
Tampico, Mexico	1986–1993	<i>Mytilus edulis</i>		18	2			[114]
Philippines	1998	<i>Perna veridis</i>	0.4–14	0.07–0.8	0.10–2.8	<0.01–0.05	<0.01	[154]
Philippines	1994–1997	<i>Perna veridis</i>	0.7–36	0.2–4.2	0.15–9.5	<0.01–0.20	<0.01–0.04	[14]
Thailand	1994–1995	<i>Perna veridis</i>	<0.01–20	1.2–38	0.25–6.0	<0.01–0.33	<0.01–0.12	[146]
Vietnam	1997	<i>Perna veridis</i>	0.2–3.4	2.4–310	0.10–1.4	0.04–0.11	<0.01–0.03	[154]
Kuwait	1998	<i>Circentia callipyga</i>	0.05–3.8	3.1		0.29	0.13	[152]
Saudi Arabia	1998	<i>Meretrix meretrix</i>	0.18–0.71	1.3		0.003–0.27	0.005–0.009	[152]
Iran	1997	<i>Saccostrea cucullata</i>	3.8	2.7		0.05	0.59	[152]
Bahrain	1984	<i>Pinctada margaritifera</i>	1.7–10.5	0.1–0.67		<d.l.–0.07	0.03–0.04	[150]

Table 5.6 Mean (and range) of concentrations (ng/g lipid weight) of organochlorine contaminants in mussels

Country	Year	PCBs	CHLs	DDTs	HCHs	HCB	Reference
Japan	1994	3000 (510–12 000)	550 (150–1800)	600 (70–2900)	28 (13–50)	8.2 (<0.60–29)	[115]
Hong Kong	1998	307 (40–710)	240 (18–750)	7700 (640–61 000)	18 (2.1–30)	<1.0 (<1.5)	[115]
South Korea	1998	170 (30–340)	25 (3.7–40)	150 (14–360)	14 (1.9–80)	2.3 (<0.4–7.3)	[115]
Malaysia	1997–1998	56 (<4.2–250)	140 (17–630)	90 (16–270)	3.9 (<0.8–12)	0.9 (<0.5–3.3)	[115]
Thailand	1994–1995	170 (5.0–1100)	80 (10–510)	380 (48–3300)	9.0 (0.16–27)	3.3 (<0.5–8.0)	[147]
Philippines	1994/1998	660 (22–2100)	120 (5.1–460)	69 (4.0–200)	4.5 (0.5–10)	0.8 (<0.4–2.0)	[14, 115]
China	1999–2001	120 (15–540)	190 (10–870)	17 000 (830–54 000)	44 (11–110)	56 (<0.9–540)	[115]
Indonesia	1998	87 (5.6–210)	19 (8.3–45)	70 (6.5–160)	2.7 (<0.6–5.3)	0.8 (<0.5–1.5)	[115]
India	1994–1997/1998	202 (7.9–650)	38 (0.2–160)	430 (29–3000)	205 (20–590)	4.4 (<0.4–63)	[115, 146]
Vietnam	1997	160 (21–450)	35 (7.0–160)	4400 (220–34 000)	5.7 (3.0–11)	0.93 (<0.5–3.5)	[115]
Cambodia	1998	33 (<1.4–220)	<0.3 (<0.4–<1.1)	23 (16–42)	<0.3 (<0.8–<1.2)	1.2 (<0.4–2.6)	[115]

their transfer to babies at a vulnerable stage of their development. A considerable number of studies have been conducted around the world to determine the exposure of children to POPs in their early development. Among human tissues, breast milk is the most convenient matrix for measuring residue levels of hydrophobic contaminants. In their guidance document on the monitoring of POPs, UNEP recommended the use of breast milk for assessing levels of environmental pollution by lipophilic substances in different areas within and between countries. However, the data that exist currently in the literature for breast milk should be interpreted with caution since the sampling and analytical procedures often vary between different laboratories. In addition, the levels of POPs in breast milk is also dependent on the age and parity of the mother, sampling period and dietary habits, and these factors make comparison even more complicated.

The most reliable study of POPs in breast milk samples from developing countries comes from work carried out by Kunisue and colleagues [103–105, 155–157]. Here, samples were collected from across Asia and analyzed within the same laboratory using the same analytical procedures. Their studies revealed that relatively high concentrations of DDT, for example, were found in mothers from Vietnam, China, Cambodia and Malaysia, more than from other countries included in their studies. To compare levels in Asia with other developing countries, selected data from other published studies [103–105, 155–164] from the literature have been compiled in Table 5.7. Other countries with elevated levels of DDT in breast milk, as shown in Table 5.7, are Zimbabwe, Mexico and Pakistan, all countries with a history of widespread usage of DDT in malaria vector and pest control.

The levels of HCHs were also found to be higher in Chinese and Indian breast milk samples than in mothers from other developing countries in Asia. The relative concentrations of these

Table 5.7 *Global comparison of POPs concentrations (ng/g l.w.) in breast milk from developing countries*

Country	Year of survey	PCBs	DDTs	HCHs	CHLs	HCB	References
China	2002	42	2100	1400	16	81	[105]
Philippines	2000	72	190	4.7	15	<0.56	[105]
Vietnam	2000	74	2100	58	2	3.9	[155]
Cambodia	1999–2000	20	1800	5.6	1.6	1.6	[105]
Malaysia	2003	80	1600	230	23	11	[108]
Indonesia	2001	33	640	14	2	2.2	[108]
India	2000	30	430	640	0.91	1	[104]
Turkey	1995–1996		2400	480		50	[161]
Iran	1991		2000	600		61	[161]
Brazil	1992	150	1700	280		12	[158]
Mexico	1997–1998		4700	60		30	[163]
Kenya	1991		470	96			[160]
Kazakhstan	1994	380	2300	2300		91	[164]
Kuwait	1999		128–3606	<d.l.–20			[159]
Ghana	2000		490			40	[123]
Jordan	1993–1997		1510	710		290	[21]
Guatemala	2001		3–557				[21]
Panama	1987		10.0–4300				[21]
Zimbabwe	1989		6000	910			[21]
Pakistan			760–5230	93–3430			[21]
Saudi Arabia			247	0–440			[21]

two chemicals in breast milk samples appear to reflect their usage patterns across Asia. Extremely high values have also been reported in samples from Pakistan and Kazakhstan. The concentration and pattern of these compounds in breast milk from Asia suggests continued usage of these OC pesticides in developing countries across Asia. This suggests that these countries may continue to serve as sources of these chemicals to the global environment.

There is limited information of levels of PCBs, HCB and CHLs in developing countries in the literature. The available information indicates that levels in breast milk may be linked to the degree of urbanization and industrialization from which samples are collected.

A recent survey was conducted of dioxins and related compounds in breast milk from mothers living close to municipal dumpsites in India, Cambodia, Vietnam, Philippines, Malaysia, Indonesia, and China to investigate the influence of uncontrolled combustion of garbage that occurs at these sites on human exposure [103, 104]. The levels of dioxins in samples from India were significantly higher than in all other samples from other countries. In addition, the differences between levels from dumpsites and reference sites were greater for the Indian samples relative to those from Cambodia and Vietnam, suggesting that the Indian residents were exposed to higher levels than mothers from other developing countries. The differences in exposure between Indian mothers and those from other countries were due to dietary intake from milk of buffaloes that were reared close to the dumpsites.

5.4 Problems Related to POPs in Developing Countries

Developing countries face some of the same problems with POPs as developed countries. However, there are other problems that are unique to developing countries. The United Nations has identified some of the problems facing developing countries with regards to POPs [165]. Problems can generally be divided into three sections: those of a technical and economic nature, those of a legal nature and those of an educational nature.

5.4.1 Economic and Technical Problems

Inevitably, a country's economic conditions will determine its technical capacity since finances are needed to build and maintain a technical infrastructure. Thus, these two types of problems faced by developing countries are linked. In most developing countries there exists a lack of financial resources to build and maintain adequate laboratories, purchase and maintain sophisticated scientific equipments and train scientific personnel. Most developing countries thus lack the scientific/analytical capabilities needed to generate the comprehensive scientific data necessary to develop proper regulatory policies with respect to POPs. In order to develop sound policies developing countries must carry out detailed, long-term and wide-ranging studies regarding POPs, including monitoring of the environment, human and ecosystem health, and products (including food products). They must also produce accurate inventories of POPs. Generation of such scientific/technical data is costly, and unfortunately developing countries often lack the economic resources to do so.

In addition, in developing countries there is often a scarcity of personnel trained to manage any existing technical infrastructure. This is compounded by the diverse demands

often placed on the limited trained personnel. Thus, it is common in developing countries to place the few trained personnel in managerial capacities outside of science. The result is often limited coordination and poor harmonization of any scientific/technical projects that are carried out in developing countries. Thus, data on POPs generated in developing countries are often difficult to compare in both a regional context and with data from developed countries.

A problem that is specific to developing countries is the lack of knowledge on how to dispose of stockpiles of POPs. This problem epitomizes the link between economic and technical issues since developing countries usually lack both the financial resources and technical capacity to dispose of significant stockpiles of POPs.

5.4.2 Legal Problems

Developing countries often lack a suitable legislative framework to deal with the issue of POPs, linking the diverse aspects of their management from source/import through use to disposal and effects. This is, of course, tied to the economic and technical problems facing developing countries since sound scientific information is necessary to develop such a suitable legislative framework. This framework must be developed in consultation with all stakeholders on the issue of POPs (users, governmental and nongovernmental organizations, international agencies). Such processes, however, are costly in both financial and human resources, which are often lacking in developing countries. Such a lack of capacity makes the legal issue quite problematic in these countries.

Another legal problem in developing countries is the ineffective enforcement of any existing regulations on POPs. The mere fact of passing legislation governing the use, disposal, etc., of POPs does not mean that developing countries have the capacity to enforce such legislation. There is often a lack of trained personnel and required resources to enforce existing regulations on POPs. An additional problem that arises in developing countries as a result of the above is that of illegal trade and use of POPs. This may involve both illegal use of POPs that have been banned and use of restricted POPs for unauthorized use. This significant problem is exacerbated by the existence, as pointed out above, of stockpiles of banned and/or restricted POPs.

5.4.3 Educational Problems

Another set of problems facing developing countries with regards to POPs is the lack of education among the population and even among decision-makers. Very often sound information on POPs does not filter down to the general population, leading to a dearth of knowledge on the dangers of POPs or the country's international obligations with regards to them. As a result, many people use POPs illegally as they are unaware of their status, and due to the fact that these compounds may be the cheapest and/or because of incorrect advice from their peers. With the lack of education/information campaigns, many people in developing countries have been known to reject alternatives. They may see proposed alternatives as ineffective or too expensive and lack the knowledge to make such judgments.

Suppliers of chemicals must also be properly trained so they do not inadvertently or willingly engage in illegal and/or inappropriate commerce of POPs, and so too must the operators of processes that may produce POPs unintentionally. This must include offering alternatives to prevent generation of POPs.

The lack of awareness and information may even extend to governmental personnel, who are then in no position to enforce legislation. For example, customs officials are often untrained in the issues surrounding POPs and do not effectively enforce legislation, exacerbating the legal problems discussed above.

5.5 Conclusions

POPs are now understood to be one of the most dangerous threats to human health and the environment today. However, there is a genuine lack of knowledge about POPs sources and releases in many developing countries. Existing data from Africa and other developing countries show concentrations of POPs equal to or higher than those in temperate or cold regions. Unfortunately, even after developed countries banned the use of many POPs, especially OC pesticides, they continued exporting them to developing countries. As a result, developing countries have experienced or are experiencing the same problems that developed countries did earlier. In addition, a more sophisticated understanding of the long-range transport of POPs has shown clearly that the same POPs that developed countries export to developing countries can potentially affect the former.

Experience and studies suggest that the problem of POPs is one that must be tackled jointly between developed and developing nations. It is not enough to ban their manufacture and use because their persistence means they continue to be found in the environment for years. Bans must be accompanied by educational programmes and real alternatives, otherwise poor inhabitants of developing countries will simply seek out the cheapest options available to them, which quite often are the banned POPs. Such alternatives might have to come via aid from developed countries.

This chapter has shown that in developing countries there is a paucity of data on quantities of POPs used, potential sources and environmental concentrations. This information is critical in order to develop plans to eliminate POPs in developing countries. The lack of data is due to lack of resources, personnel and facilities to carry out the necessary studies. What is needed is joint action whereby developed countries aid developing ones in establishing a cadre of trained professionals and suitable facilities to both conduct monitoring and to implement disposal plans. The international community needs to respond in a coherent and cost-effective fashion with measures acceptable from a public health and socioeconomic perspective. The available data indicates that POPs are indeed present in the environment and humans in developing countries and are likely to have an adverse impact on the environment and public health.

References

1. Darnerud, P. O. Toxic effects of brominated flame retardants in man and in wildlife. *Environment International*, **29**: 841–853(2003).
2. Legler, J., Brouwer, A. Are brominated flame retardants endocrine disruptors? *Environment International*, **29**: 879–885 (2003).
3. Santillo, D., Johnston, P. Playing with fire: the global threat presented by brominated flame retardants justifies urgent substitution. *Environment International*, **29**: 725–734(2003).
4. Lohmann, R., Breivik, K., Dachs, J., Muir, D. C. Global fate of POPs: current and future research directions. *Environmental Pollution*, **150**: 150–165 (2007).

5. Tanabe, S. Contamination by persistent toxic substances in the Asia-Pacific Region. In *Persistent Organic Pollutants in Asia. Sources, Distributions Transport and Fate* (eds A. Li S. Tanabe G. Jiang J. P. Giesy P. K. S. Lam). Elsevier Ltd, 2007, pp. 773–817.
6. Tanabe, S., Ramu, K., Isobe, T., Takahashi, S. Brominated flame retardants in the environment of Asia-Pacific: an overview of spatial and temporal trends. *Journal of Environmental Monitoring*, **10**: 188–197 (2008).
7. Wong, M. H., Wu, S. C., Deng, W. J., Yu, X. Z., Luo, Q., Leung, A. O. W., *et al.* Export of toxic chemicals – a review of the case of uncontrolled electronic-waste recycling. *Environmental Pollution*, **149**: 131–140 (2007).
8. Liu, X., Tanaka, M., Matsui, Y. Electrical and electronic waste management in China: progress and the barriers to overcome. *Waste Management Research*, **24**: 92–101 (2006).
9. Brigden, K., Labunska, I., Santillo, D., Johnston, P. Chemical contamination at e-waste recycling and disposal sites in Accra and Korforidua, Ghana. Greenpeace, 2008.
10. UNEP DG-E. E-waste, the hidden side of IT equipment's manufacture and use. Chapter 5 – Early warning on emerging environmental threats, 2005 (cited). Available from: <http://www.grid.unep.ch>.
11. Walker, K., Vallero, D. A., Lewis, R. G. Factors influencing the distribution of lindane and other hexachlorocyclohexanes in the environment. *Environmental Science and Technology*, **33**: 4373–4378 (1999).
12. Li, Y. F., Cai, D. J., Singh, A. Technical hexachlorohexane use trends in China and their impact on the environment. *Archives of Environmental Contamination and Toxicology*, **35**: 688–697 (1998).
13. Barakat, A. O. Assessment of persistent toxic substances in the environment of Egypt. *Environment International*, **30**: 309–322 (2004).
14. Prudente, M., Malarvanna, G., Tanabe, S. Persistent toxic substances in the Phiippine environment. In *Persistent Organic Pollutants in Asia. Sources Distribution, Transport and Fate* (eds A. Li S. Tanabe G. Jiang P. K. S. Lam). Elsevier Ltd, 2007, pp. 559–585.
15. Barra, R., Colombo, J. C., Eguren, G., Gamboa, N., Jardim, W. F., Mendoza, G. Persistent organic pollutants (POPs) in Eastern and Western South American countries. *Reviews of Environmental Contamination and Toxicology*, **185**: 1–33 (2006).
16. FCI. Marketing in the Asia-Pacific, September 1996.
17. Li, Y.-F. Global technical hexachlorocyclohexane usage and its contamination consequences in the environment: from 1948 to 1997. *Science of the Total Environment*, **232**: 121–158 (1999).
18. Voldner, E. C., Li, Y.-F. Global usage of selected persistent organochlorines. *Science of the Total Environment*, **160/161**: 201–210 (1995).
19. Karnatz, A. Obsolete pesticide disposal project. Department of Agriculture, Food and Markets, Montpelier, Vermont, 1991.
20. Schimpf, W.A. Obsolete pesticide stocks in developing countries. In *Chemistry of Crop Protection. Progress and Prospects in Science and Regulation* (eds G. Voss G. Ramos). Wiley-VCH, Weinheim, 2003, pp. 40–53.
21. UNEP. Regionally based assessment of persistent toxic substances. UNEP Chemicals, 2003.
22. Jain, V. Disposing of pesticides in the third world. *Environmental Science and Technology*, **26** (2): 226–229 (1992).
23. de-Voogt, P., Brinkman, U. A. T. (eds). *Production, Properties and Usage of Polychlorinated Biphenyls*. Elsevier–North Holland, Amsterdam, 1989.
24. Vallack, H. W., Bakker, D. J., Brandt, I., Brostrom-Lunden, E., Brouwer, A., Bull, K. R., *et al.* Controlling persistent organic pollutants – what next? *Environmental Toxicology and Pharmacology*, **6**: 143–175 (1998).
25. Breivik, K., Sweetman, A., Pacyna, J. M., Jones, K. C. Towards a global historical emission inventory for selected PCB congeners – a mass balance approach. 3. An update. *Science of the Total Environment*, **377**(2–3): 296–307 (2007).
26. Breivik, K., Sweetman, A., Pacyna, J. M., Jones, K. C. Towards a global historical emission inventory for selected PCB congeners – a mass balance approach 1. Global production and consumption. *Science of the Total Environment*, **290**: 181–198 (2002).

27. Meijer, S. N., Ockenden, W., Breivik, K., Grimalt, J. O., Jones, K. C. Global distribution and budget of PCBs and HCB in background surface soils: implications for sources and environmental processes. *Environmental Science and Technology*, **37**(4): 667–672 (2003).
28. Eduljee, G. H. PCBs in the environment. *Chemistry in Britain*, **24**: 241–244 (1988).
29. Jones, K. C., de Voogt, P. Persistent organic pollutants (POPs): state of the science. *Environmental Pollution*, **100**: 209–221 (1999).
30. UNECE. Protocol on persistent organic pollutants under the 1979 convention on long-range transport air pollution. Report ECE/EB.Air/60, Geneva, Switzerland, 1998.
31. UNECE. Preparation of an internationally binding instrument for implementing international action on certain persistent organic pollutants. Report UNEP/POPs/Inc.1/6, Geneva, Switzerland, 1998.
32. Kishida, M., Imamura, K., Maeda, Y., Lan, T. T. N., Thao, N. T. P., Viet, P. H. Distribution of persistent organic pollutants and polycyclic aromatic hydrocarbons in sediment samples from Vietnam. *Journal of Health Science*, **53**(3): 291–301 (2007).
33. Anyinam, C. A. Transboundary movements of hazardous wastes: the case of toxic waste dumping in Africa. *International Journal of Health Service*, **21**(4): 759–777 (1991).
34. Pellow, D. N. The politics of illegal dumping: an environmental justice framework. *Qualitative Sociology*, **27**(4): 511–525 (2004).
35. Vir, A. K. Toxic trade with Africa. *Environmental Science and Technology*, **23**: 23–25 (1989).
36. Wania, F., Mackay, D. Tracking the distribution of persistent organic pollutants: control strategies for these contaminants will require a better understanding of how they move around the globe. *Environmental Science and Technology*, **30**(9): 390A–396A (1996).
37. Baker, J. I., Hites, R. A. Is combustion the major source of polychlorinated dibenzo-*p*-dioxins and dibenzofurans to the environment? A mass balance investigation. *Environmental Science and Technology*, **34**: 2879–2886 (2000).
38. Deutsch, D. G., Goldfarb, T. D. PCDD/PCDF contamination following a plastic fire in a university lecture hall building. *Chemosphere*, **17**: 2423–2431 (1988).
39. Gullett, B. K., Lemieux, P. M., Lutes, C. C., Winterrowd, C. K., Winters, D. L. Emissions of PCDD/F from uncontrolled domestic waste burning. *Chemosphere*, **43**: 721–725 (2001).
40. Eduljee, G. H., Dyke, P. An updated inventory of PCDD and PCDF emissions sources in the UK. *Science of the Total Environment*, **177**: 303–321 (1996).
41. Brzuzy, L. P., Hites, R. A. Estimating the atmospheric deposition of polychlorinated dibenzo-*p*-dioxins from soils. *Environmental Science and Technology*, **29**(8): 2092–2098 (1995).
42. Welsch-Pausch, K., McLachlan, M. S. Fate of airborne polychlorinated dibenzo-*p*-dioxins and dibenzofurans in agricultural ecosystems. *Environmental Pollution*, **102**(1): 129–137 (1998).
43. Rappe, C. Sources and environmental concentrations of dioxins and related compounds. *Pure and Applied Chemistry*, **68**(9): 1781–1789 (1996).
44. Kocan, A., Bencko, V., Sixl, W. Polychlorinated dibenzo-*p*-dioxins (PCDDs) and dibenzofurans (PCDFs) in the hair of people living on municipal refuse dumping sites in Cairo (Egypt). *Toxicology and Environmental Chemistry*, **36**: 33–37 (1992).
45. Crutzen, P. J., Andrea, M. O. Biomass burning in the tropics – impacts on atmospheric chemistry and biogeochemical cycles. *Science*, **250**: 1669–1678 (1990).
46. Kasischke, E. S., Penner, J. E. Improving global estimates of atmospheric emissions from biomass burning. *Journal of Geophysical Research Atmospheres*, **109**: D14 (2004).
47. Zheng, M.-H., Bao, Z.-C., Wang, K.-O., Yang, H., Xu, X.-B. Polychlorinated dibenzo-*p*-dioxins and dibenzofurans in lake sediments from Chinese schistosomiasis areas. *Bulletin of Environmental Contamination and Toxicology*, **59**: 653–656 (1997).
48. Bao, Z.-C., Wang, K. O., Kang, J. X., Zhao, L. W. Analysis of polychlorinated dibenzo-*p*-dioxins and dibenzofurans in pentachlorophenol and sodium pentachlorophenate. *Environmental Chemistry (China)*, **14**: 317–321 (1995).
49. Zheng, M.-H., Chu, S.-G., Sheng, G.-Y., Min, Y.-S., Bao, Z.-C., Xu, X. B. Polychlorinated dibenzo-*p*-dioxins and dibenzofurans in surface sediments from Pearl River Delta in China. *Bulletin of Environmental Contamination and Toxicology*, **66**: 504–507 (2001).

50. Wu, W. Z., Schramm, K.-W., Henkelmann, B., Xu, Y., Yediler, A., Kettrup, A., PCDD/Fs, PCBs HCHs, and HCB in sediment and soil of Ya-Er Lake area in China: results on residue levels and correlation to organic carbon and particle size. *Chemosphere*, **34**: 191–202 (1997).
51. Wu, W. Z., Schramm, K.-W., Xu, Y., Kettrup, A. Mobility and profiles of polychlorinated dibenzo-*p*-dioxins and dibenzofurans in sediment of Ya-Er Lake. China. *Water Research*, **35**: 3025–3033 (2001).
52. Wu, W. Z., Schramm, K.-W., Kettrup, A. Bioaccumulation of polychlorinated dibenzo-*p*-dioxins and dibenzofurans in sediments of Ya-Er Lake. China. *Water Research*, **35**: 1141–1148 (2001).
53. Dwernychuk, L. W. Dioxin hot spots in Vietnam. *Chemosphere*, **60**: 998–999 (2005).
54. Schecter, A., Cao, D. L., Papke, O., Prange, J., Constable, J. D., Matsuda, M., *et al.* Recent dioxin contamination from agent orange in residents of a southern Vietnam city. *Journal of Occupational Environmental Medicine*, **43**: 435 (2001).
55. Connel, D. W., Miller, G. J., Mortimer, M. R., Shaw, G. R., Anderson, S. M. Persistent lipophilic contaminants and other chemical residues in the southern hemisphere. *Environmental Science and Technology*, **29**: 47–82 (1999).
56. Bailey, R. E. Global hexachlorobenzene emissions. *Chemosphere*, **43**: 167–182 (2001).
57. Beyer, A., Mackay, D., Matthies, M., Wania, F., Webster, E. Assessing long-range transport potential of persistent organic pollutants. *Environmental Science and Technology*, **34**: 699–703 (2000).
58. Moody, C. A., Field, J. A. Perfluorinated surfactants and the environmental implications of their use in fire-fighting foams. *Environmental Science and Technology*, **34**(18): 3864–3870 (2000).
59. Kissa, E., *Fluorinated Surfactants and Repellants*, 2nd edition. Marcel Dekker, New York, 2001.
60. Giesy, J. P., Kannan, K. Perfluorochemical surfactants in the environment. *Environmental Science and Technology*, **36**: 147A–152A. (2002).
61. Kannan, K., Newsted, J., Halbrook, R. S., Giesy, J. P. Perfluorooctanesulfonates and related fluorinated hydrocarbons in mink and river otters from the United States. *Environmental Science Technology*, **36**: 2566–2571 (2002).
62. Guruge, K. S., Taniyasu, S., Yamashita, N., Manage, P. M. Occurrence of perfluorinated acids and fluorotelomers in waters from Sri Lanka. *Marine Pollution Bulletin*, **54**: 1663–1672 (2007).
63. Kannan, K., Koistinen, J., Beckmen, K., Evans, T., Jones, P. D., Eero, H., *et al.* Accumulation of perfluorooctane sulfonate in marine mammals. *Environmental Science and Technology*, **35**: 1593–1598 (2001).
64. Kannan, K., Franson, J. C., Bowerman, W. W., Hansen, K. J., Jones, P. D., Giesy, J. P. Perfluorooctane sulfonate in fish eating water birds including bald eagles and albatrosses. *Environmental Science Technology*, **35**: 3065–3070 (2001).
65. Falandysz, J. Polychlorinated naphthalenes: an environmental update. *Environmental Pollution*, **101**: 77–90 (1998).
66. Harner, T., Bidleman, T., Lee, R. G. M., Jones, K. C. Polychlorinated naphthalenes in the atmosphere. In *Persistent Bioaccumulative and Toxic Chemicals II. Assessment and New Chemicals* (eds R.L. Lipnik, B. Jansson, D. Mackay, M. Petreas). American Chemical Society, Washington, 2000.
67. Crookes, M. J., Howe, P. D. Environmental hazard assessment: halogenated naphthalenes. Report TSD/13, Department of the Environment, London, 1993.
68. Schneider, M., Stieglitz, L., Will, R., Zwick, G. Formation of polychlorinated naphthalenes on fly ash. *Chemosphere*, **37**: 2055–2070 (1998).
69. Theisen, J., Maulshagen, A., Fuchs, J. Organic and inorganic substances in the copper slag ‘Kieselrot’. *Chemosphere*, **26**: 881–896 (1993).
70. Jaward, F. M., Barber, J. L., Booij, K., Jones, K. C. Spatial distribution of atmospheric PAHs and PCNs along a north–south Atlantic transect. *Environmental Pollution*, **132**: 173–181 (2004).
71. Kannan, K., Imagawa, T., Blankenship, A. L., Giesy, J. P. Isomer-specific analysis and toxic evaluation of polychlorinated naphthalenes in soil, sediment, and biota collected near the site of a former chlor-alkali plant. *Environmental Science and Technology*, **32**: 2507–2514 (1998).

72. Oehme, M., Mano, S., Mikalsen, A. Formation and presence of polyhalogenated and polycyclic compounds in the emissions of small and large scale municipal waster incinerators. *Chemosphere*, **16**: 102–114 (1987).
73. Helm, P., Bidleman, T., Stern, G., Koczanski, K. Polychlorinated naphthalenes and coplanar polychlorinated biphenyls in beluga whale (*Delphinapterus leucas*) and ringed seal (*Phoca hispida*) from the eastern Canadian Arctic. *Environmental Pollution*, **119**(1): 69–78 (2002).
74. Jarnberg, U., Asplund, L., de Wit, C., Grafström, A. K., Haglund, P., Jansson, B., *et al.* Polychlorinated biphenyls and polychlorinated naphthalenes in Swedish sediment and biota: levels, patterns, and time trends. *Environmental Science and Technology*, **27**: 1364–1374 (1993).
75. Kannan, K., Yamashita, N., Imagawa, T., Decoen, W., Khim, J. S., Day, R. M., *et al.* Polychlorinated naphthalenes and polychlorinated biphenyls in fishes from Michigan waters including the Great Lakes. *Environmental Science and Technology*, **34**(4): 566–572 (2000).
76. Gevao, B., Al-Omair, A., Sweetman, A., Al-Bahloul, M., Al-Ali, L., Helaleh, M., *et al.* Passive-sampler derived air concentrations for polybrominated diphenyl ethers and polycyclic aromatic hydrocarbons in Kuwait. *Environmental Toxicology and Chemistry*, **25**(6): 1496–1502 (2006).
77. Harrad, S., Hunter, S. Spatial variation in atmospheric levels of PBDEs in passive air samples on an urban–rural transect. *Organohalogen Compounds*, **66**: 3786–3792 (2004).
78. Rayne, S., Ikononou, M. G., Antcliffe, B. Rapidly increasing polybrominated diphenyl ether concentrations in the Columbia River system from 1992 to 2000. *Environmental Science and Technology*, **37**(13): 2847–2854 (2003).
79. Zhu, L. Y., Hites, R. A. Temporal trends and spatial distributions of brominated flame retardants in archived fishes from the Great Lakes. *Environmental Science and Technology*, **38**(10): 2779–2784 (2004).
80. Hassanin, A., Breivik, K., Meijer, S. N., Steinnes, E., Thomas, G. O., Jones, K. C. PBDEs in European background soils: levels and factors controlling their distribution. *Environmental Science and Technology*, **38**(3): 738–745 (2004).
81. Gevao, B., Beg, M. U., Al-Ghadban, A. N., Al-Omair, A., Helaleh, M., Zafar, J. Spatial distribution of polybrominated diphenyl ethers in coastal marine sediments receiving industrial and municipal effluents in Kuwait. *Chemosphere*, **62**: 1078–1086 (2006).
82. Song, W., Ford, J. C., Li, A., Mills, W. J., Buckley, D. R., Rockne, K. J. Polybrominated diphenyl ethers in the sediments of the Great Lakes. 1. Lake Superior. *Environmental Science and Technology*, **38**(12): 3279–3285 (2004).
83. Gevao, B., Al-Bahloul, M., Al-Ghadban, A. N., Al-Omair, A., Ali, L., Zafar, J., *et al.* House dust as a source of human exposure to polybrominated diphenyl ethers in Kuwait. *Chemosphere*, **64**: 603–608 (2006).
84. Jones-Otazo, H. A., Clarke, J. P., Diamond, M., Archbold, J. A., Ferguson, G., Harner, T., *et al.* Is house dust the missing exposure pathway for PBDEs? An analysis of the urban fate and human exposure to PBDEs. *Environmental Science and Technology*, **39**(14): 5121–5130 (2005).
85. Gearhart, J., Posselt, H. Toxic at any speed. Chemicals in cars and the need for safe alternatives. The Ecology Center, Ann Arbor, Michigan, January, 2006.
86. Hites, R. A. Polybrominated diphenyl ethers in the environment and in people. *Environmental Science and Technology*, **38**(4): 945–956 (2004).
87. North, K. D. Tracking polybrominated diphenyl ether releases in wastewater treatment plant effluent, Palo Alto, California. *Environmental Science and Technology*, **38**(17): 4484–4488 (2004).
88. Alae, M., Wenning, R. J. The significance of brominated flame retardants in the environment: current understanding, issues and challenges. *Chemosphere*, **46**: 579–582 (2002).
89. de Wit, C. A. An overview of brominated flame retardants in the environment. *Chemosphere*, **46**: 583–624 (2002).
90. D’Silvia, K., Fernandes, A., Rose, M. Brominated organic micropollutants – igniting the flame retardant issue. *Critical Reviews in Environmental Science and Technology*, **34**: 141–207 (2004).
91. Ikononou, M. G., Rayne, S., Addison, R. F. Exponential increase of brominated flame retardants, polybrominated diphenyl ethers, in the Canadian Arctic from 1981 to 2000. *Environmental Science and Technology*, **36**: 1886–1892 (2002).

92. Betts, K. S. Mounting concern over brominated flame retardants. *Environmental Science and Technology*, **35**: 274A–275A (2001).
93. McDonald, T. A. A perspective on the potential health risks of PBDEs. *Chemosphere*, **46**: 745–755 (2003).
94. Rahman, F., Langford, K. H., Scrimshaw, M. D., Lester, J. N. Polybrominated diphenyl ether (PBDE) flame retardants. *Science of the Total Environment*, **275**: 1–17 (2001).
95. Meironyte, D., Bergman, A., Noren, K. Analysis of brominated diphenyl ethers in human milk. *Organohalogen Compounds*, **35**: 387–390 (1998).
96. Meironyte, D., Noren, K., Bergman, A. Analysis of polybrominated diphenyl ethers in Swedish human milk. A time-related trend study, 1972–1997. *J. Toxicology and Environmental Health A*, **58**: 101–113 (1997).
97. Noren, K., Meironyte, D. Contaminants in Swedish human milk. Decreasing levels of organochlorine and increasing levels of organobromine compounds. *Organohalogen Compounds*, **35**: 1–4 (1998).
98. Noren, K., Meironyte, D. Certain organochlorine and organobromine contaminants in Swedish human milk in perspective of past 20–30 years. *Chemosphere*, **40**: 1111–1123 (2000).
99. Alaei, M., Arias, P., Sjodin, A., Bergman, A. An overview of commercially used brominated flame retardants, their applications, their use patterns in different countries/regions and possible modes of release. *Environment International*, **29**: 683–689 (2003).
100. Lueung, A. O. W., Luksemburg, W. J., Wong, A. S., Wong, M. H. Spatial distribution of polybrominated diphenyl ethers and polychlorinated dibenzo-*p*-dioxins and dibenzofurans in soil and combusted residue at Guiyu, an electronic waste recycling site in Southern China. *Environmental Science and Technology*, **41**: 2730–2737 (2007).
101. Kemmlin, S., Hahn, O., Jann, O. Emissions of organophosphate and brominated flame retardants from selected consumer products and building materials. *Atmospheric Environment*, **37**: 5485–5493 (2003).
102. Minh, N. H., Minh, T. B., Watanabe, M., Kunisue, T., Monirith, I., Tanabe, S., *et al.* Open dumping site in Asia developing countries: A potential source of polychlorinated dibenzo-*p*-dioxins and polychlorinated dibenzofurans. *Environmental Science and Technology*, **37**: 1493–1501 (2003).
103. Kunisue, T., Watanabe, M., Iwata, H., Subramanain, A., Monirith, I., Minh, T. B., *et al.* Dioxins and related compounds in human breast milk collected around open dumpsites in Asian developing countries: bovine milk as a potential source. *Archives of Environmental Contamination and Toxicology*, **47**: 414–426 (2004).
104. Kunisue, T., Watanabe, M., Someya, M., Monirith, I., Minh, T. B., Subramanain, A., *et al.* PCDDs, PCDFs, PCBs and organochlorine insecticides in human breast milk collected from Asian developing countries: risk assessment for infants. *Organohalogen Compounds*, **58**: 285–288 (2002).
105. Kunisue, T., Someya, M., Kayama, F., Jin, Y., Tanabe, S. Persistent organochlorines in human breast milk collected from primiparae in Dalian and Shenyang. *China. Environmental Pollution*, **131**: 381–392 (2004).
106. Minh, T. B., Minh, N. H., Iwata, H., Takahashi, S., Viet, P. H., Tuyen, B. C., *et al.* Persistent organic pollutants in Vietnam: levels, patterns, trends, and human health implications. In *Persistent Organic Pollutants in Asia. Sources Distributions Transport and Fate* (eds A. Li, S. Tanabe, G. Jiang, J. P. Giesy, P. K. S. Lam). Elsevier Ltd, 2007, pp. 515–555.
107. Kan-attireklap S. Subramanain A. Tanabe S. Persistent toxic substances in Thailand. In *Persistent Organic Pollutants in Asia. Sources, Distributions Transport and Fate* (eds A. Li, S. Tanabe, G. Jiang, J. P. Giesy, P. K. S. Lam). Elsevier Ltd, 2007, pp. 487–513.
108. Sudaryanto A. Takahashi S. Tanabe S. Persistent toxic substances in the environment of Indonesia. In *Persistent Organic Pollutants in Asia. Sources, Distributions Transport and Fate* (eds A. Li, S. Tanabe, G. Jiang, J. P. Giesy, P. K. S. Lam). Elsevier Ltd, 2007, pp. 587–627.
109. Li, A., Tanabe, S., Jiang, G., Giesy, J. P., Lam, P. K. S. (eds), *Persistent Organic Pollutants in Asia. Sources, Distribution, Transport, and Fate*. Elsevier Ltd, 2007.

110. Pozo, K., Harner, T., Wania, F., Muir, D. C., Jones, K. C., Barrie, L. A. Toward a global network for persistent organic pollutants in air: results from the GAPs study. *Environmental Science and Technology*, **40**(16): 4867–4873 (2006).
111. Iwata, H., Tanabe, S., Sakai, N., Nishimura, A., Tatsukawa, R. Geographical distribution of persistent organochlorines in air, water and sediments from Asia and Oceania, and their implications for global redistribution from lower latitudes. *Environmental Pollution*, **85**: 15–33 (1994).
112. Iwata, H., Tanabe, S., Sakai, N., Tatsukawa, R. Distribution of persistent organochlorines in the oceanic air and surface seawater and the role of ocean on their global transport and fate. *Environmental Science and Technology*, **27**(6): 1080–1098 (1993).
113. Kalantzi, O. I., Alcock, R. E., Johnston, P. A., Santillo, D., Stringer, R. L., Thomas, G. O., *et al.* The global distribution of PCBs and organochlorine pesticides in butter. *Environmental Science and Technology*, **35**: 1013–1018 (2001).
114. Sericano, J. L., Wade, T. L., Jackson, T. J., Brooks, P. W., Tripp, B. W., Farrington, J. W., *et al.* Trace organic contamination in the Americas: an overview of the US national status and trends and the international 'Mussel Watch' programmes. *Marine Pollution Bulletin*, **31**(4–12): 214–225 (1995).
115. Monirith, I., Ueno, D., Takahashi, S., Nakata, H., Sudaryanto, A., Subramanian, A. N., *et al.* Asia-Pacific mussel watch: monitoring contamination of persistent organochlorine compounds in coastal waters of Asian countries. *Marine Pollution Bulletin*, **46**: 281–300 (2003).
116. Tanabe, S., Prudente, M., Kan-atireklap, S., Subramanian, A. Mussel watch: marine pollution monitoring of butyltins and organochlorines in coastal waters of Thailand, Philippines and India. *Ocean and Coastal Management*, **43**: 819–839 (2000).
117. Wong, F., Alegria, H. A., Jantunen, L., Bidleman, T. F., Salvador-Figueroa, M., Gold-Bouchot, G., *et al.* Organochlorine pesticides in soils and air of southern Mexico: chemical profiles and potential for soil emissions. *Atmospheric Environment*, **42**: 7737–7745 (2008).
118. Shen, L., Wania, F., Lei, Y. D., Teixeira, C., Muir, D. C., Bidleman, T. F. Hexachlorocyclohexanes in the North American atmosphere. *Environmental Science and Technology*, **38**(4): 965–975 (2004).
119. Batterman, S. A., Chernyak, S. M., Gounden, Y., Matoane, M., Naidoo, R. N. Organochlorine pesticides in ambient air in Durban, South Africa. *Science of the Total Environment*, **397**: 119–130 (2008).
120. Galindo-Reyes, J. G., Fossato, V. U., Villagrana-Lizarraga, C., Dolci, F. Pesticides in water, sediments, and shrimp from a coastal lagoon off the Gulf of California. *Marine Pollution Bulletin*, **38**(9): 837–841 (1999).
121. DouAbul, A. A. Z., Al-Saad, H. T., Darmoian, S. A. Distribution of petroleum residues in surficial sediments from the North-West region of the Arabian Gulf. *Marine Pollution Bulletin*, **15**: 198–200 (1984).
122. Thao, V. D., Kawano, M., Tatsukawa, R. Organochlorine residues in soils from Taiwan Thailand and Vietnam. *Environmental Pollution*, **81**: 61 (1993).
123. Ntow, W. J. Organochlorine pesticides in water, sediment, crops, and human fluids in a farming community in Ghana. *Archives of Environmental Contamination and Toxicology*, **40**: 557–563 (2001).
124. Wurl, O., Obbard, J. P. Organochlorine pesticides, polychlorinated biphenyls and polybrominated diphenyl ethers in Singapore's coastal marine sediments. *Chemosphere*, **58**: 925–933 (2005).
125. Douabul, A. Z., Al-Saad, H. T., Al-Timari, A., Al-Rekabi, N. Tigris-Euphrates Delta: a major source of pesticides to the Shatt Al-Arab River (Iraq). *Archives of Environmental Contamination and Toxicology*, **17**: 405–418 (1988).
126. Gevaio, B., Beg, M. U., Al-Omair, A., Helaleh, M., Zafar, J. Spatial distribution of polychlorinated biphenyls in coastal marine sediments receiving industrial effluents in Kuwait. *Archives of Environmental Contamination and Toxicology*, **50**: 166–174 (2006).
127. ROPME. Regional report on the state of the marine environment. ROPME, Kuwait, 2000.
128. Lee, D. B., Prudente, M., Tanabe, S., Tatsukawa, R. Organochlorine residues in soils and sediments from Manila and nearby provinces. *Toxicology and Environmental Chemistry*, **60**: 171–181 (1997).

129. Ahmed, M. T., Ismail, S. M. M., Mabrouk, S. S. Residues of some chlorinated hydrocarbon pesticides in rainwater, soil and groundwater and their influence on some soil microorganisms. *Environment International*, **24**: 665–670 (1998).
130. Miglioranza, K. S. B., Moreno, J. E. A., Moreno, V. J., Osterrieth, M. L., Escalate, A. H. Fate of organochlorine pesticides in soils and terrestrial biota of Los Padres pond watershed Argentina. *Environmental Pollution*, **105**: 91–99 (1999).
131. EMC. Monitoring of persistent organic pollutants in the coastal hydrosphere of Indonesia. Country Report UNU, Japan, 2003.
132. Aichner, B., Glaser, B., Zech, W. Polycyclic aromatic hydrocarbons and polychlorinated biphenyls in urban soils from Kathmandu. *Nepal. Organic Geochemistry*, **38**: 700–715 (2007).
133. Daly, G. L., Lei, Y. D., Teixeira, C., Muir, D. C., Castillo, L. E., Juantunen, L. M. M., *et al.* Organochlorine pesticides in the soils and atmosphere of Costa Rica. *Environmental Science and Technology*, **41**: 1124–1130 (2007).
134. Westbom, R., Hussein, A., Megersa, N., Retta, N., Mathiasson, L., Bjorklund, E. Assessment of organochlorine pesticide pollution in Upper Awash Ethiopian state farm soils using selective pressurized liquid extraction. *Chemosphere*, **72**: 1181–1187 (2008).
135. Kammerbauer, J., Moncada, J. Pesticide residue assessment in three selected agricultural production systems in the Choluteca River Basin of Honduras. *Environmental Pollution*, **103**: 171–181 (1998).
136. Zhang, G. Q., Parker, A., Li, X., Li, J., Wang, X. Distribution of organochlorine pesticides and polycyclic aromatic hydrocarbons in soils from the Pearl River delta, South China. In 3rd Asia-Pacific Symposium on *Environmental Chemistry*, GuangZhou, China, 2001, p. 93.
137. ICAR. All India Coordinated Research Project on Pesticide Residue. Anand. ICAR Annual Report, 2002.
138. Fu, J., Mai, B., Sheng, G., Zhang, G., Wang, X., Peng, P., *et al.* Persistent organic pollutants in environment of the Pearl River Delta China: an overview. *Chemosphere*, **52**: 1411–1422 (2003).
139. Thao, V. D., Kawano, M., Matsuda, M., Wakimoto, T., Tatsukawa, R., Cau, H. D., *et al.* Chlorinated hydrocarbon insecticide and polychlorinated biphenyl residues in soils from southern provinces of Vietnam. *International Journal of Environmental Analytical Chemistry*, **50**: 147–159 (1993).
140. Thao, V. D., Kawano, M., Tatsukawa, R. Persistent organochlorine residues in soils from tropical and sub-tropical Asian countries. *Environmental Pollution*, **81**: 61–71 (1993).
141. Iwata, H., Tanabe, S., Ueda, K., Tatsukawa, R. Persistent organochlorine residues in air, water, sediments, and soils from the Lake Baikal region Russia. *Environmental Science and Technology*, **29**(3): 792–801 (1995).
142. Goldberg, E. D., Bowen, V. T., Farrington, J. W., Harvey, G., Martin, J. H., Parker, P. L., *et al.* The mussel watch. *Environmental Conservation*, **5**: 101–125 (1978).
143. de Brito, A. P. X., Bruning, I. M. R. D. A. Chlorinated pesticides in mussels from Guanabara Bay, Rio de Janeiro, Brazil. *Marine Pollution Bulletin*, **44**: 71–81 (2002).
144. Ramesh, A., Tanabe, S., Subramanain, A., Mohan, D., Venugopalan, V. K., Tatsukawa, R. Persistent organic residues in green mussels from coastal waters of South India. *Marine Pollution Bulletin*, **21**: 587–590 (1990).
145. Klumpp, D. W., Huansheng, H., Humphrey, C., Xinhong, W., Codi, S. Toxic contaminants and their biological effects in coastal waters of Xiamen, China. I. Organic pollutants in mussels and fish tissues. *Marine Pollution Bulletin*, **44**: 752–760 (2002).
146. Kan-atireklap, S., Tanabe, S., Sanguansin, J., Tabucanon, M. S., Hungspreugs, M. Contamination by butylin compounds and organochlorine residues in green mussels (*Perna viridis* L.) from Thailand coastal waters. *Environmental Pollution*, **97**: 79–89 (1997).
147. Kan-atireklap, S., Yen, N. T. H., Tanabe, S., Subramanain, A. Butylin compounds and organochlorine residues in green mussel (*Perina viridis* L.) from India. *Toxicology and Environmental Chemistry*, **67**: 409–424 (1998).
148. IAEA. Contaminant Screening Project. First Mission Report, IAEA/ROPME, Monaco, 1999.
149. IAEA. Contaminant Screening Project. Second Mission and Final Report, IAEA/ROPME, Monaco, 1998.

150. Fowler, S. W. Agrochemicals. In *The Gulf Ecosystem: Health and Sustainability* (eds N. Y. Khan, M. Munawar, A. R. G. Price). Backhuys Publishers, Leiden, 2002, pp. 193–204.
151. Hong, H., Wang, X., Xu, L., Chen, W., Zhang, L., Zhang, Z. Trace organic pollutants in the Southeast estuarine environments of China. *Journal of Environmental Science and Health A*, **35**: 1833–1847 (2000).
152. IAEA. Contaminant Screening Project. Mid-term Progress Report, Monaco, 1996.
153. Li, Y.-F., Bidleman, T., Barrie, L. A., McConnell, L. L. Global hexachlorocyclohexane use trends and their impact on the Arctic atmospheric environment. *Geophysical Research Letters*, **25**: 39–41 (1998).
154. Monirith, I., Ueno, D., Takahashi, S., Nakata, H., Sudaryanto, A., Subramanian, A., *et al.* Asia-Pacific mussel watch: monitoring contamination of persistent organochlorine compounds in coastal waters of Asian countries. *Marine Pollution Bulletin*, **46**: 281–300 (2003).
155. Minh, N. H., Someya, M., Minh, T. B., Kunisue, T., Iwata, H., Watanabe, M., *et al.* Persistent organochlorine residues in human breast milk from Hanoi and Hochiminh, Vietnam: contamination, accumulation kinetics and risk assessment for infants. *Environmental Pollution*, **129**: 431–441 (2004).
156. Sudaryanto, A., Kunisue, T., Tanabe, S., Niida, M., Hashim, H. Persistent organic compounds in human breast milk from mothers living in Penang and Kedah, Malaysia. *Archives of Environmental Contamination and Toxicology*, **49**: 429–437 (2005).
157. Sudaryanto, A., Kunisue, T., Kajiwaru, N., Iwata, H., Adibroto, T. A., Hartono, P., *et al.* Specific accumulation of organochlorines in human breast milk from Indonesia: levels, distribution, accumulation, kinetics and infant health risk. *Environmental Pollution*, **139**: 107–117 (2006).
158. Paumgarten, F. J. R., Cruz, C. M., Chahoud, I., Palavinskas, R., Mathar, W. PCDDs, PCDFs, PCBs, and other organochlorine compounds in human milk from Rio de Janeiro, Brazil. *Environmental Research*, **83**: 293–297 (2000).
159. Saeed, T., Sawaya, W., Ahmad, N., Rajagopal, S., Dashti, B., Al-Awadhi, S. Assessment of the levels of chlorinated pesticides in breast milk in Kuwait. *Food Additives and Contaminants*, **17**(12): 1013–1018 (2000).
160. Kinyamu, J. K., Kanja, L. W., Skaare, J. U., Maitho, T. E. Levels of organochlorine pesticide residues in milk of urban mothers in Kenya. *Bulletin of Environmental Contamination and Toxicology*, **60**: 732–738 (1998).
161. Cok, I., Bilgili, A., Ozdemir, M., Bilgili, N., Burgaz, S. Organochlorine pesticide residues in human breast milk from agricultural regions of Turkey, 1995–1996. *Bulletin of Environmental Contamination and Toxicology*, **59**: 577–582 (1997).
162. Cok, I., Karakaya, A. E., Afkham, B. L., Burgaz, S. Organochlorine pesticide contaminants in human milk samples collected in Tebriz (Iran). *Bulletin of Environmental Contamination and Toxicology*, **63**: 444–450 (1999).
163. Waliszewski, S. M., Aguirre, A. A., Infanzon, R. M., Silva, C. S., Siliceo, J. Organochlorine pesticide levels in maternal adipose tissue, maternal blood serum, umbilical blood serum, and milk from inhabitants of Veracruz, Mexico. *Archives of Environmental Contamination and Toxicology*, **40**: 432–438 (2001).
164. Hooper, K., Petreas, M. X., She, J., Visita, P., Winkler, J., Mckinney, M., *et al.* Analysis of breast milk to assess exposure to chlorinated contaminants in Kazakhstan: PCBs and organochlorine pesticides in southern Kazakhstan. *Environmental Health Perspectives*, **105**: 1250–1254 (1997).
165. UNEP. Regionally based assessment of persistent toxic substances. Sub-Saharan Africa Regional Report, United Nations Environment Programme, December 2002.

6

Sources, Fate and Effects of Contaminant Emissions in Urban Areas

Erin Hodge and Miriam Diamond

Department of Geography, University of Toronto, Toronto, Ontario, Canada

6.1 Introduction

With a quick look out the window of any first world city one sees the fabric of urban life – infrastructure constructed to facilitate the activities and flows of people, goods and services. Turning one's eyes to within one's office or home, you see a wide array of products, commodities and infrastructure. Much of what you see has been built or manufactured since 1900 and, more so, since World War II. This is reflected in the exponential rate of resource use since the early 1900s, which is predominantly nonrenewable construction materials that comprise our cities and especially the city infrastructure (Matos and Wagner, 1998; Brunner and Rechberger, 2001). An extremely small fraction of the total material can be classified as POPs. Some POPs were synthesized to facilitate industrial and construction activities that allowed the safe expansion and efficiency of infrastructure and human activities that are concentrated in cities. POPs in this list include polychlorinated naphthalenes (PCNs) and polychlorinated biphenyls (PCBs) as stabilizers of dielectric fluids, PCBs in exterior paints and sealants to increase product longevity and performance, PCBs in some paint pigments and perfluorinated compounds on carpets and fabrics to minimize their staining and, again, to prolong their useful life. Other POPs such as polychlorinated dibenzodioxins and furans (PCDD/Fs), polybrominated dibenzodioxins and furans (PBDD/Fs), polyaromatic hydrocarbons (PAHs) and PCNs are produced as we combust materials either for energy or to reduce our waste.

Cities are reservoirs of POPs, just by virtue of the enormous stock of products and materials geographically concentrated in the urban technosphere. Considerably less than 1% of the reservoir of POPs ‘leak’ out of the materials and products into which they were intentionally added. Urban form, due to its simplistic architecture (relative to nature) and disturbed hydrologic regime, promotes the mobility of the POPs that escape. The ‘leakage’ of POPs to the surrounding environment is of concern with respect to human and ecosystem exposure, as explained in Chapter 8.

This chapter reviews the sources and types of POPs emissions in urban areas and ensuing environmental effects, examines some of the chemical interactions and transformations that occur within complex chemical mixtures that are found in urban areas and discusses some of the links between urban form and chemical emissions. We identify gaps, of which there are many, in the scientific understanding of contaminant dynamics in urban areas. We conclude by discussing the implications of urban contaminants on health and recommend ways to maximize the health benefits afforded by urban areas.

6.2 Cities in the 21st Century

Rapid urbanization has occurred on a global scale in the past century. Urban areas import vast quantities of materials and energy from a global geographic range (Newman, 1999), have high rates of material and energy use, and concentrate large stocks of a wide diversity of chemicals (Brunner and Rechberger, 2001). These factors elevate the rates of chemical emissions to the areas surrounding cities (e.g. Hafner and Hites, 2003; Diamond and Hodge, 2007). Many of the particular challenges and opportunities facing urban areas with respect to environmental quality are related to the elevated concentrations of chemical contaminants in virtually all urban media.

The lopsided material–energy balance between urban areas and their hinterlands is reflected by urban–rural gradients in concentrations of contaminants in air (Cotham and Bidleman, 1995), vegetation (Wagrowski and Hites 1996), sediments (Van Metre *et al.*, 2000), surface water (Asher *et al.*, 2007) and soil (Wong *et al.*, 2009). In addition, because the contaminants concentrated in urban areas are mobile and are exported on either a regional or global scale (Newman, 1999; Brook *et al.*, 2002) urban areas become regional point sources of contaminants. Through atmospheric transport and then deposition of POPs, many such chemicals are imported back into cities through the food supply (Harrad and Diamond, 2006; see Chapter 8).

Although urban areas are nodes of emissions, this does not imply that human populations should become more dispersed to improve the sustainability of human settlements or health. On the contrary, urban areas present particular opportunities to improve sustainability and to mitigate health risks that arise from anthropogenic activity (Jackson, 2003). Some urban areas, characterized by high densities, embody inherent opportunities to enact large-scale improvements and efficiencies, such as mass transit and centralized, tertiary sewage treatment. Well-planned urban areas potentially can support the lowest *per capita* quantities of chemical emissions possible for human settlements (e.g. Jacob and Lopez, 2009). Thus, urban areas can be managed to minimize environmental impacts, outside obvious point source regulations. Human health is often higher in cities because of the numerous opportunities available and improved access to institutions including health care.

Economic and demographic shifts have changed the profile of urban chemical emissions in high-income countries (HICs). Historically, industrial point source emissions, which tended to occur in urbanized areas with large work forces, were obvious and egregious contributors to urban environmental degradation. The development of cleaner industrial processes in specific instances (Hill *et al.*, 2002; Hilson, 2000; Overcash, 2002), the implementation of policies and regulations drafted for the control of point source emissions and urban zoning regulations have been effective at reducing and/or relocating such emissions within cities (Douglas *et al.*, 2002; Salzman, 1999; Perdue *et al.*, 2003). Concurrently, many cities have 'de-industrialized' in HICs, including North America and Europe (Salzman, 1999; Alderson, 1999; Ansari, 1992), and much of the more polluting industries have relocated to low-income countries (LICs) (Rock, 2002). An alternative view is that commodities that are consumed in HIC cities are increasingly produced in LICs: product manufacturing can and does pollute LICs whereas product use can pollute HIC cities, although to a lesser extent (e.g. Hertwich and Peters, 2009). As a result, in HICs, the relative importance to environmental degradation of the numerous non-point-source emissions (e.g. stationary and mobile fossil fuel combustion by both domestic and commercial activities) present in cities has increased (Salzman, 1999). Controlling diffuse non-point-source emissions may be a more difficult challenge than addressing the obvious smokestack 'culprits' of previous decades, but is nonetheless important because the cumulative effect of numerous emissions, even in trace amounts, can be appreciable concentrations in environmental media that are subsequently contaminated.

Population growth is associated with absolute increases in chemical emissions, but this general tendency is affected substantially by factors such as demography, infrastructure, urban form and societal wealth. In North America, the effect of urban sprawl and rising rates of car ownership on total vehicle kilometres travelled (VKT), and hence on emissions associated with use of motor vehicles, is one example of how urban form and rising affluence can affect chemical emissions (Frank *et al.*, 2000; Van Metre *et al.*, 2000; Ewing *et al.*, 2002; Cameron *et al.*, 2004). The trend of increasing household numbers is an example of a demographic trend with implications for rates of chemical emission. In urban regions worldwide, the number of separate households is increasing faster than total population (Liu, J. G., *et al.*, 2003), a trend that is expected to increase *per capita* demands for energy, household products, building materials and other goods, and hence increase chemical emissions related to the use and manufacture of such items (Liu, J. G., *et al.*, 2003).

Although chemical emissions are important contributors to environmental degradation in virtually all cities, there are significant differences between cities located in high and low income countries with respect to particular trends in urban form and infrastructure, patterns of resource use and chemical fate. The insights and observations that we have garnered in the course of our research primarily relate to cities in HICs and, consequently, such cities will be the focus of this chapter. The focus on cities in HICs is not meant to downplay the ongoing adverse and serious effects of environmental contamination of cities and megacities in many LICs.

6.3 Urban Emission Sources

The list below summarizes some of the sources of POPs typically emitted in urban areas. The list is not exhaustive, but provides a view of the wide range of sources that contribute to emissions and environmental degradation in urban centres:

- Vehicles emit a wide range of organic and inorganic constituents from fuel combustion, uncombusted fuels, crankcase leakage and the operation of catalytic converters. Polyaromatic hydrocarbons (PAHs) and trace levels of polychlorinated dibenzodioxins and furans (PCDD/Fs) are among the numerous compounds emitted as a result of vehicle operation (e.g. Rogge *et al.*, 1993a, 1993b; Chang *et al.*, 2004).
- Vehicles also emit flame retardants and plasticizers such as phthalates from their interior seating, dashboards and other plastic components. Vehicles are, presumably, sources of some bisphenol A through the deterioration of polycarbonate plastics used in high-impact plastic vehicle components. Extremely high concentrations of polybrominated diphenyl ethers (PBDEs) have been measured in cars as their degassing is promoted by the heating that occurs while the engine is in use (Gearhart and Posselt, 2006; Harrad *et al.*, 2008; Petreas and Oros, 2009).
- Products from fossil fuel combustion are emitted from residential heating systems, e.g. PAH (Traynor *et al.*, 1990).
- Trace emissions occur from building materials and infrastructure. For example, phthalates are released from polyvinyl chloride plastics, chlorinated solvents from paint strippers, degreasers, aerosols and adhesives, and CFCs from blown foam in which they were used as blowing agents; flame retardants (e.g. hexabromocyclododecane, or HBCD, and tetrabromobisphenol A, or TBBPA) are also used in construction foams (Rudel *et al.*, 2008; Abdallah *et al.*, 2008; Covaci *et al.*, 2006, 2009; Stapleton *et al.*, 2008). Materials such as flame retarded electronic cables and sealants in buildings constructed between World War II and the mid-1970s can contain PCBs (Kohler *et al.*, 2005; Herrick *et al.*, 2004; Rudel *et al.*, 2008). PCBs and PCNs can degas from electrical infrastructure (Helm and Bidleman, 2003; Du and Rodenburg, 2007).
- Older exterior paints and floor finishes can release PCBs, furniture finishes can release phthalates as well as more volatile solvents and paint pigments can release 'new' PCBs (e.g. PCB 11) as pigment by-products (Rudel and Perovich, 2009; Hu *et al.*, 2008).
- Road sealants can contain extremely high concentrations of PAH that are released over time (Mahler *et al.*, 2005; Van Metre and Mahler, 2005; Van Metre *et al.*, 2009).
- Pesticides are widely used outdoors in urban areas and use of phenoxy herbicides such as 2,4-D and prometon in urban areas exceeds that in rural areas (Templeton *et al.*, 1998; Struger *et al.*, 1994).
- Pesticides are also used indoors, from which release to outdoors occurs via ventilation (see Chapter 7). Indoor use of pesticides often results in indoor air and dust concentrations 10–100 times greater than that in outdoor air and surface soil because of minimal degradation indoors. Chlordane is still released via indoor air as a result of its application to house foundations to control termites in urban areas from the 1940s to its ban in the US in 1988 and global discontinuation of production in 1997 (Leone *et al.*, 2000; Offenberg *et al.*, 2004).
- Fabrics and polyurethane furniture, circuit boards, high-impact plastic casings around electronic equipment such as televisions, telephones, computers, hair dryers, etc., are sources of flame retardants such as PBDEs, HBCD, TBBPA and 'new' generation flame retardants bis(2,4,6-tribromophenoxy)ethane (BTBPE), (2-ethylhexyl)tetrabromophthalate (TBPH), decabromodiphenyl ethane (DeBDethane) and 2,4,6-tribromophenol (2,4,6-TB) (see Chapters 2, 5, 7 and 8) (Kemmlin *et al.*, 2003; Stapleton *et al.*, 2008; Takigami *et al.*, 2008, 2009; Kolic *et al.*, 2009). Traces of PBDD/F can

be found in plastics and dust collected from plastics containing highly brominated flame retardants (Kajiwara *et al.*, 2008). Surface treatments on textiles, food packaging, paper, nonstick cookware, etc., emit fluoropolymers (e.g. Scotch Guard, although production has ceased) (Ellis *et al.*, 2001; Fromme *et al.*, 2009; Bjorklund *et al.*, 2009; D'Eon *et al.*, 2009).

- Persistent chemicals that do not necessarily originate from within the urban area are atmospherically deposited after medium- or long-range transport. These include compounds such as DDT, DDE, DDD and hexachlorocyclohexanes (HCHs). It is often difficult to distinguish between the proportion of these chemicals that are transported atmospherically from agricultural regions versus those released within urban areas (Gingrich *et al.*, 2001). DDT was commonly used as a general agricultural pesticide and for controlling bat populations and pests in urban areas (Bidleman *et al.*, 1998; Gouin *et al.*, 2007).
- Sanitary and ultimately wastewater treatment plant (WWTP) discharges release numerous contaminants from hygiene and personal care products such as chlorinated benzenes (predominantly 1,2-dichlorobenzene) from deodorizers, *d*-limonene and diethyl and dibutyl phthalate from perfumes, soaps, air fresheners and detergents, styrene from carpets, rubber and adhesives (Edwards *et al.*, 2001; Yu and Crump, 1998; Salthammer *et al.*, 1999; Wolkoff, 1995), synthetic musks from deodorants, cleaning products, etc. (Rimkus *et al.*, 1994; Peck and Hornbuckle, 2004, 2006a), polydimethylsiloxanes (PDMSs) and other medium and high molecular weight siloxanes used in high volume in a wide variety of personal care and consumer products (Mueller *et al.*, 1995; Parker *et al.*, 1999), triclosan, which is a broad spectrum antibacterial of which 95% is used in 'down the drain' consumer products and the remainder in domestic surfaces such as chopping boards and food wrappers (Reiss *et al.*, 2002; Haggard *et al.*, 2006), and legal and illicit pharmaceuticals and drugs such as caffeine, cocaine, ibuprofen, carbamazepine, etc. (Kolpin *et al.*, 2004; Glassmeyer *et al.*, 2008; Loos *et al.*, 2009; van Nuijs *et al.*, 2009; Watkinson *et al.*, 2009).
- Structural fires in cities and fires at waste landfills and demolition sites emit a wide range of compounds, some of which are compounds present in materials (e.g. PBDEs, HBCD, PCBs) while others are produced by the low-temperature combustion process (e.g. PCDD/Fs and PBDD/Fs) (Farrar *et al.*, 2004b; Butt *et al.*, 2004b; Rayne *et al.*, 2005). The US EPA reported substantial amounts of numerous contaminants from simulated open fibreglass combustion, including benzo[*a*]pyrene, dibenzofuran, lead, naphthalene, phenanthrene, phenol, styrene and toluene (Lutes and Ryan, 1994). Analysis of the fibreglass used in building industry materials showed significant halogen concentrations that are probably due to the presence of brominated flame retardants in the material. The *de novo* production of some compounds, such as PCDD/Fs, PCNs, PCBs and PBDD/Fs, are favoured by low-temperature combustion of organic materials and are catalysed by metals such as copper in wiring under low oxygen conditions (Lemieux *et al.*, 2002; Helm and Bidleman, 2003). Firefighting foams are a source of PFCs (Moody *et al.*, 2002).
- Medical waste and municipal solid waste incineration has been the source of PCDD/Fs as well as PCNs, PAHs and PCBs, although emissions from the new generation of incinerators are much lower than those of decades past (Lemieux *et al.*, 2002; Capuano *et al.*, 2005; Kim *et al.*, 2009).

6.4 Urban Emissions and Urban–Rural Gradients

Emissions from urban sources increase the concentrations of nonagricultural, and even some presumed agricultural POPs, in virtually all urban media. Emissions are difficult to estimate as they originate from myriad non-point sources. Hites and co-workers have found significant relationships between atmospheric concentrations of PCBs, PAHs and PCDD/Fs with population (Hafner and Hites, 2003; Hafner *et al.*, 2005; Venier *et al.*, 2009). For PCDD/Fs, the slope of log–log concentration–population plots are slightly greater than 1, indicating that a doubling of the population results in slightly more than double the air concentrations, whereas the slope is ~ 0.5 for PAHs. This lower slope is likely to be attributable to the high photoreactivity of PAHs versus PCDD/Fs (Hafner *et al.*, 2005; Venier *et al.*, 2009). The observation by Venier *et al.* (2009) of seasonal periodicity in PCDD/F concentrations at remote Great Lakes sites but not an urban Chicago site is consistent with a constant emission source from Chicago, such as medical and municipal waste incineration, but not residential heating, and seasonal transport processes to the remote sites. Although the emission–population relationship holds generally, it breaks down at small spatial scales within urban areas where emissions from industrial areas with low population densities can be important (Du *et al.*, 2009).

Emissions have been estimated using a variety of modelling methods. Diamond and co-workers have used the fugacity-based multimedia urban model, or MUM, to ‘back-calculate’ emissions. Jones–Otazo *et al.* (2005), using a 470 km² area centred on downtown Toronto, estimated that Σ PBDE (12 congeners in penta- and octa-formulations) emission rates varied from 20 to 118 mg/capita year or 0.2 to 0.9 $\mu\text{g}/\text{m}^2$ year. Using the same approach, Clarke *et al.* (in prep.) back-calculated emissions of Σ PCB from downtown Hamilton, Canada, an industrial city located at the western end of Lake Ontario. They estimated that Σ PCB emissions representing 104 congeners (calculated as the sum of di- to nona-chlorobiphenyl homologues) ranged from 0.14 to 4 mg/m² year or 0.55 to 1.5 mg/capita year. Diamond *et al.* (2009) used a similar approach to calculate Σ PCB emissions (70 congeners) for Toronto, Canada, with a population of 2.5 million and a metropolitan population of over 5 million. Their estimate of 0.14–1.4 mg/m² year was very similar to that of Clarke *et al.* (in prep.), as well as modelled estimates of Eisenreich (2000) and Totten *et al.* (2004) of 0.4–3.6 and 0.4 mg/m² year for Chicago and New York City respectively. Expressed on a per capita basis, PCB emissions have been reported as 35–350, 360 and 1600 mg/capita year for Toronto, Wilrijk, Belgium and Zurich respectively (Diamond *et al.*, 2009; Van Gerven *et al.*, 2004; Gasic *et al.*, 2009).

These emissions have resulted, not surprisingly, in concentration gradients from urban to rural locations (Tables 6.1 and 6.2). The magnitude of the gradients typically ranges from 2 to 20 for POPs that are either predominantly in the gas phase (PCBs) or split between particle and gas phases (chlordanes, PBDEs). These relatively small gradients are the result of the long atmospheric travel distances of gas-phase compounds. In comparison, more particle-phase compounds or those that are more photoreactive with shorter travel distances have larger gradients, such as 20–60 for PAH in soils. Compounds with more recent histories of use, such as PBDEs, have less clear urban–rural gradients (Strandberg *et al.*, 2001; Hoh and Hites, 2005; Harner *et al.*, 2006). Urban–rural gradients in soils can be obscured by uncertain past uses or sources of urban soils such as residential suburban developments located near or on former industrial areas (Wong *et al.*, 2009).

Table 6.1 Summary of ratios of urban-rural concentrations of POPs

Medium	Chemical	Ratio	Location	Reference	Measurement Method	Comments
Air	PCB, gas-phase	3–5	Great Lakes	Hafner & Hites 2003	hi-vol	Magnitude very sensitive to wind direction
	PCB	≤8	Great Lakes	Tasdemir <i>et al.</i> 2004	hi-vol	
	PCB	≤20	Philadelphia-Camden	Totten <i>et al.</i> 2004, 2006	hi-vol	
	PCB	5–10	7 sites along 80 km N-S transect Toronto	Harner <i>et al.</i> 2004	PUF passive	
	PBDE	3–6	5 sites from L Michigan through East-Central US	Hoh and Hites 2005	hi-vol	
	PBDE	2–5	10 sites along 80 km transect in West Midlands	Harrad & Hunter 2006	PUF passive	
	PBDE	1–2	7 sites along 80 km N-S transect Toronto	Harner <i>et al.</i> 2004	PUF passive	
	Chlordane	5	Chicago & Great Lakes sites	Strandberg <i>et al.</i> 2001	hi-vol	
	Chlordane	4	15 sites including Toronto & Chicago	Gouin <i>et al.</i> 2007	PUF passive	
	Chlordane	1–2	7 sites along 80 km N-S transect Toronto	Harner <i>et al.</i> 2004	PUF passive	
	Dechlorane Plus	5	24 urban, 27 rural sites in China	Ren <i>et al.</i> 2008	PUF passive	
	DDT	3	Chicago & Great Lakes sites	Strandberg <i>et al.</i> 2001	hi-vol	

(continued)

Table 6.1 (Continued)

Medium	Chemical	Ratio	Location	Reference	Measurement Method	Comments
Atm Deposition	PCB	5	Hudson River estuary	Totten <i>et al.</i> 2004	gas absorption, wet & dry bulk wet & dry	
	PAH	2.5–6	Seine River	Garban <i>et al.</i> 2002		
Surface Films	PCB	50	7 sites along 80 km N-S transect Toronto	Gingrich <i>et al.</i> 2001		
	PCB	8–20	Southern Ontario	Wu <i>et al.</i> 2008		
	PBDE	10–20	7 sites along 80 km N-S transect Toronto	Butt <i>et al.</i> 2004a		
	PCDD/F	15–20	Southern Ontario	Butt <i>et al.</i> 2009		
Vegetation	PAH	30	7 sites along 80 km N-S transect Toronto	Gingrich <i>et al.</i> 2001		
	PAH	10	Illinois, Indiana, Michigan	Wagrowski & Hites 1996		
Soil	PCB	10	7 sites along Seine River basin	Motelay-Massei <i>et al.</i> 2004		
	PCB	> 100	3 sites in Romania	Covaci <i>et al.</i> 2001		
	PCB	12	10 sites along 80 km transect in West Midlands	Jamshidi <i>et al.</i> 2007		
	PBDE	15–20	10 sites along 80 km transect in West Midlands	Harrad & Hunter 2006		
	PAH	5	7 sites along Seine River basin	Motelay-Massei <i>et al.</i> 2004		
			4	7 sites along 80 km N-S transect Toronto	Wong <i>et al.</i> 2004, 2009	
	Chlordane	2	7 sites along 80 km N-S transect Toronto	Wong <i>et al.</i> 2009		

Table 6.2 Summary of POP concentrations measured in urban, suburban and rural locations. Rural locations were generally located within 300 km of urban locations and thus are not considered remote

Medium	Chemical	Congeners or Compounds	Unit	Concentration Urban	Concentration Suburban	Concentration Rural	Location	Reference	Measurement Method	Comments
Air	PCB - gas phase	87	pg/m ³	270–14200		230-690	Chicago and South Haven	Simcik <i>et al.</i> , 1997	hi-vol	
	PCB- particle phase	87	pg/m ³	7.2–590		ND				
	PCB	105	pg/m ³	3100 (32)	530 (30)	660 (18)	Chicago, Sturgeon Point, Sleeping Bear Dunes	Strandberg <i>et al.</i> 2001	hi-vol	(% std error)
	PCB - gas phase	60 peaks, 93 congeners	pg/m ³	1260–3250	430-540	150-220	Camden, Jersey City	Totten <i>et al.</i> 2004	hi-vol	
	PCB - total	35-50	pg/m ³	1160 (223–2360)	217 (54.5-2253)	46.3 (16.5-78.2)	Manchester, NW England	Halsall <i>et al.</i> 1999	hi-vol	
		35-50	pg/m ³	1490 (415–3710)			Cardiff, Wales			
	PCB	60	pg/m ³	350 ± 218		230 ± 180	97 sites in China	Zhi <i>et al.</i> 2008	PUF passive	
	PCB	90	pg/m ³	445	167	116	7 sites along 80 km N-S transect Toronto	Harner <i>et al.</i> 2004	PUF passive	summer/fall
	PCB	90	pg/m ³	424	66	NA	7 sites along 80 km N-S transect Toronto	Motelay-Massei <i>et al.</i> 2005	PUF passive	winter
	PCB	90	pg/m ³	1100	129	269	7 sites along 80 km N-S transect Toronto		PUF passive	spring
	PCB	48	pg/m ³	930	239	83	12 sites GL (Toronto, Chicago/ Downsview, Sturgeon Pt/8 rural)	Gouin <i>et al.</i> 2005	PUF passive	

(continued)

Table 6.2 (Continued)

Medium	Chemical	Congeners or Compounds	Unit	Concentration <i>Urban</i>	Concentration <i>Suburban</i>	Concentration <i>Rural</i>	Location	Reference	Measurement Method	Comments
Air	PCB	97	pg/m ³	3000		200	Camden, Lum's Pond	Du <i>et al.</i> 2009	hi-vol	NJADN
	PCB	77	pg/m ³	357	88	72	10 sites along 80 km transect West Midlands	Jamshidi <i>et al.</i> 2007	PUF passive	
	PCDD/F	17 congeners 2,3,7,8 substituted	fg WHO TEQ/m ³	35 ± 3	13 ± 2	7.4 ± 1.4	Chicago, Sturgeon Point, Sleeping Bear Dunes	Venier <i>et al.</i> 2009	hi-vol	
	PAH	12 (acenaphthylene to benzo[<i>g,h,i</i>]perylene)	ng/m ³	2.7–5.1	8.3–20.1	0.14–0.8	London, Hazelrigg UK, Rorvik	Prevedouros <i>et al.</i> 2004	hi-vol	
	PAH - gas phase	19	ng/m ³	27–430		4.0–55	Chicago and South Haven	Simcik <i>et al.</i> , 1997	hi-vol	
	PAH-particle phase	19	ng/m ³	3.2–460		0.1–1.1			hi-vol	
	PAH	17 (acenaphthylene to benzo[<i>g,h,i</i>]pyrene)	ng/m ³	58.5	18.4	11.5	7 sites along 80 km N-S transect in Toronto	Motelay-Massei <i>et al.</i> 2005	PUF passive	summer/fall
				17.0	14.8	8.3				winter
				17.5	3.9	3.5				spring
	Dechlorane Plus		pg/m ³	15.6 ± 15.1		3.5 ± 5.6	97 sites in China	Ren <i>et al.</i> 2008	PUF passive	
	PBDE	7 (BDE-47, 99, 100, 153, 154, 190, 209)	pg/m ³	52 (30)	7.2 (13)	15 (29)	Chicago, Sturgeon Point, Sleeping Bear Dunes	Strandberg <i>et al.</i> 2001	hi-vol	(% std error)

PBDE	15, from BDE-17 to 183	pg/m ³	17.5	8.8	8.2	6 sites along 80 km N-S transect in Toronto	Harner <i>et al.</i> 2006	PUF passive	summer/fall
			8.1	24.4	2.7				winter
			20	27	24				spring/summer
PBDE	6 (BDE-28, 47, 99, 100, 154, 153)	pg/m ³	34	23	8.6	12 sites GL (Toronto, Chicago/Downsview, Sturgeon Pt/8 rural)	Gouin <i>et al.</i> 2005	PUF passive	
PBDE	6 (BDE-28, 47, 99, 100, 153, 154)	pg/m ³	21	12	3.9	6 sites along 80 km transect West Midlands	Harrad & Hunter 2006	PUF passive	
Musks	HHCB, galaxolide, gas phase	ng/m ³	0.8	0.1	0.04	Iowa City and environs	Peck & Hornbuckle 2006b	hi-vol	median
Musks	AHTN tonalide, gas phase	ng/m ³	0.3	0.1	0.03				
Chlordane	trans-nonachlor cis-chlor-dane trans-chlordane	pg/m ³	28	7.8	8.8	Toronto, Chicago/Downsview and Sturgeon Pt/8 rural sites	Gouin <i>et al.</i> 2007	PUF	
			39	8.2	9.0				
			43	7.7	8.1				
Chlordane	trans-nonachlor cis-chlor-dane trans-chlordane	pg/m ³	31	8.1	15	6 sites along 80 km N-S transect in Toronto	Harner <i>et al.</i> 2004		
			25	8.9	19				
			27	8.7	16				

(continued)

Table 6.2 (Continued)

Medium	Chemical	Congeners or Compounds	Unit	Concentration <i>Urban</i>	Concentration <i>Suburban</i>	Concentration <i>Rural</i>	Location	Reference	Measurement Method	Comments
	Chlordane	trans-nonachlor, cis-and trans-chlordane, cis-heptachlorepoxyde, oxychlordane	pg/m ³	240 (46)	67 (26)	52 (39)	Chicago, Sturgeon Point, Sleeping Bear Dunes	Strandberg <i>et al.</i> 2001	hi-vol	(% std error)
	DDT	o,p-DDD, DDE, DDT	pg/m ³	110 (39)	55 (27)	35 (44)	Chicago, Sturgeon Point, Sleeping Bear Dunes	Strandberg <i>et al.</i> 2001	hi-vol	(% std error)
Precipitation	PAH	16 (naphthalene to indeno[1,2,3-c,d]pyrene)	ng/L	221		25	Paris, 50 km distance	Garban <i>et al.</i> 2002		
Surface Films	PCB	89	ng/m ²	95 (5–5800)	14 (4-160)	1.8 (0.6-0.7)	7 sites along 80 km N-S transect in Toronto	Gingrich <i>et al.</i> 2001		
	PCB	15(PCB-8,18,28, 52,49,101, 118,153, 105,137/ 138,156/1 71,180, 209)	ng/m ²	263 117		38 5		Wu <i>et al.</i> 2008		winter spring

	PBDE	9 (BDE-28, 47, 66, 99, 100, 153, 154, 183, 209)	ng/m ²	9.0 (2.5–14.5)	1.1	0.56	7 sites along 80 km N-S transect in Toronto	Butt <i>et al.</i> 2004a
	PCDD/F	Homologues tetra- to octa	pg/m ²	140 (47.7–3010)	8.1	19.2	Toronto to northern Ontario	Butt <i>et al.</i> 2009
	PAH	44	ng/m ²	6100 (900–62000)	1800 (1300-2600)	210(60-600)	7 sites along 80 km N-S transect in Toronto	Gingrich <i>et al.</i> 2001
Vegetation	PAH	18 (acenaphthylene to benzol[ghi]pyrene, and coronene)	ng/g dry wt maple leaves	1600 ± 210	510 ± 100	220 ± 52	Illinois, Indiana, Mi	Wagrowski & Hites 1996
Sediment	PCBs	10 (CB-28, 52, 95, 101, 118, 136, 138, 149, 153, 180)	ug/kg dry wt	23	1.90	0.64	7 sites along 80 km N-S transect in Toronto	Wong <i>et al.</i> 2009
Soil	PCB	7 (CB-28,52, 101, 118, 153)	ug/kg dry wt	100.15	10.79	10.8	7 sites along Seine River basin	Motelay-Massei <i>et al.</i> 2004
	PCB	9	ug/kg dry wt	722	57.3	4	3 sites, Romania	Covaci <i>et al.</i> 2001
	PCB	77	ug/kg dry wt	6313.3	1146.7	568.5	10 sites along 80 km transect West Midlands	Jamshidi <i>et al.</i> 2007
	PCB	10 (CB-28, 52, 95, 101, 118, 136, 138, 149, 153, 180)	ug/kg dry wt	14	5	0.76	7 sites along 80 km N-S transect in Toronto	Wong <i>et al.</i> 2009

(continued)

Table 6.2 (Continued)

Medium	Chemical	Congeners or Compounds	Unit	Concentration <i>Urban</i>	Concentration <i>Suburban</i>	Concentration <i>Rural</i>	Location	Reference	Measurement Method	Comments
Soil	PAH	14 (fluorene to indeno [1,2,3-c,d] pyrene)	ug/kg dry wt	3940	2180	695	Rouen, Honfleur, Forest of Brotonne	Motelay-Massei <i>et al.</i> 2004		
	PAH	12 (fluorene to benzo[g,h,i] pyrene)	ug/kg dry wt	2836	319	61	7 sites along 80 km N-S transect in Toronto	Wong <i>et al.</i> 2004		forest soils
	PAH	15 (acenaphthylene to benzo[g,h,i]perylene)	ug/kg	2900	387.5	58	7 sites along 80 km N-S transect in Toronto	Wong <i>et al.</i> 2009		
	PBDE	6 (BDE-28, 47, 99, 100, 153, 154)	ug/kg dry wt	3890	321	216.55	11 sites along 80 km transect in Westmidlands UK	Harrad & Hunter 2006		
	Chlordane	trans-nona-chlor, cis-and trans-chlordane	ug/kg dry wt	0.98	0.15	0.38	7 sites along 80 km N-S transect in Toronto	Wong <i>et al.</i> 2009		

In addition to POPs having urban–rural gradients, emission sources in cities produce vertical gradients. Farrar *et al.* (2004a), Moreau-Guigon *et al.* (2007) and Li *et al.* (2009) have measured higher concentrations at first and second storey heights than above 300 m of PCBs, PBDEs, PAHs and the organochlorine pesticides HCH, DDT and HCB. However, the trend is not always consistent, which also points to the influence of meteorological conditions and regional transport on concentration profiles.

The contamination of receiving waters nearby urban areas has been well documented and attributed to the discharge of stormwater runoff via combined sewer overflows and industrial and municipal effluent (Golomb *et al.*, 2001; Foster *et al.*, 2000), as well as to atmospheric deposition (Brunciak *et al.*, 2001; Offenberg and Baker, 1997; Simcik *et al.*, 1997). The effect of the ‘urban atmospheric plume’ on chemical loadings has been documented for Chesapeake Bay (Offenberg and Baker, 1997), Lake Michigan (Simcik *et al.*, 1997), New Jersey estuary (Brunciak *et al.*, 2001; Du *et al.*, 2009) and the Hudson River estuary (Totten *et al.*, 2004). For example, Offenberg and Baker (1997) estimated that Chicago, Illinois, contributes 50 to 400% more wet deposition of PCBs than background precipitation to near-shore Lake Michigan. In some cases, atmospheric deposition may be the principal source of some volatile PAHs to urban surface waters (Nelson *et al.*, 1998). Van Metre *et al.* (2000) documented the increase in concentrations over time of PAHs in the sediments of surface waters located near urban areas. The PAH signature was attributable strictly to indirect, atmospheric deposition and not to direct discharges (Van Metre *et al.*, (2000)).

Several methods have been used to discern the sources of atmospheric concentrations, including the distinction between fresh emissions versus older emissions, cycling and recycling in the environment and those subject to regional and long-range transport. Gingrich *et al.* (2001) and Harner *et al.* (2004) used PCB congener profiles in window films and passive air samples respectively to infer a fresher signal in downtown Toronto in contrast to rural profiles that were enriched with lower molecular weight PCBs. They concluded that the higher molecular weight congeners were deposited closer to sources (i.e. downtown Toronto). Zhang *et al.* (2008) and Motelay-Massei *et al.* (2004) found similar urban fractionation patterns in PCB congeners between urban and rural air and soil samples at 97 sites located in China and PCB congeners in soils along the Seine River basin in France respectively.

Rodenburg and co-workers used positive matrix factorization (PMF) as a more formal statistical method to distinguish sources of PCBs based on congener profiles (Du and Rodenburg, 2007; Du *et al.*, 2008, 2009). Coupled with potential source contribution analysis, they were able to distinguish geographically the source(s) of PCBs in the PMF factors. The overall outcome of their studies was to identify locations in the Philadelphia–Camden area from which higher and lower molecular weight PCB emissions originated, some of which were temperature dependent while others were not. In other words, they concluded that PCBs have many, diffuse, sources in the region.

A version of the congener profiling method to trace the origin of air concentrations compares the ratios of compounds within a compound class to those within the technical mixtures. This has been done for DDT and chlordanes in window films (Gingrich *et al.*, 2001) and passive air samples (Gouin *et al.*, 2007). For example, Gouin *et al.* reported ratios of *trans*- to *cis*-chlordanes in passive air samples from Chicago and Toronto of 1.22 and 1.13 respectively, which were close to the ratio in the technical mixture of 1.16. In

comparison, they calculated ratios of 0.72–0.88 at three rural sites around the Great Lakes. Gouin *et al.* (2007) concluded that fresh emissions supported air concentrations in the two cities whereas air concentrations originated from an aged source in rural areas due to the depletion of *trans*-chlordane. However, they also remarked that the geographic pattern of the ratio showed that urban emissions had minimal influence on rural air concentrations.

Insights into whether the emissions are from ‘fresh’ versus aged sources has also been inferred from the strength of the relationship between gas-phase air concentrations and temperature using the Clausius–Clapeyron equation. When gas-phase air concentrations are supported by temperature-dependent volatilization from a surface, such as PCBs volatilizing from external building sealants, the slope of the Clausius–Clapeyron equation should yield the enthalpy of vaporization. A weak relationship has been interpreted as an indication of advection as the dominant source of air concentrations. Halsall *et al.* (1999) clearly demonstrated this by finding a strong temperature dependence of PCB air concentrations in the cities of Manchester and Cardiff, UK, but weaker relationships at rural sites, except at one rural site that was influenced by an urban centre. They concluded that urban PCB air concentrations were attributable to the release of a readily available reservoir. However, the calculated enthalpies of vaporization were not consistent with PCBs being at equilibrium with the source(s), suggesting that they were released from sources such as indoor air, in addition to temperature-dependent volatilization. Peck and Hornbuckle (2006b) also found strong relationships between gas-phase air concentrations and temperature of the two synthetic musks HHCB or galaxolide (1,3,4,6,7,8-hexahydro-4,6,6,7,8,8-hexamethylcyclopenta-(g)-2-benzopyran) and AHTN or tonalide (1-(5,6,7,8-tetrahydro-3,5,5,6,8,8-hexamethyl-2-naphthalenyl)-ethanone). However, in contrast to Halsall *et al.* (1999), Peck and Hornbuckle found a stronger relationship at rural and suburban sites, compared to a weaker relationship at urban sites. Together, these results suggest that the release of a ‘fresh’ source such as musks from indoor air may not show temperature-dependent outdoor air concentrations whereas concentrations supported by releases from surfaces such as building sealants or vegetation would show temperature dependence. Thus, the strength of the Clausius–Clapeyron equation of temperature versus gas-phase air concentrations does not provide a unique indication of an emission source.

Enantiomeric signatures of chiral compounds have also been used to discern releases from ‘fresh’ versus aged sources where a racemic signature is indicative of a fresh source and vice versa. Robson and Harrad (2004) were the first to use atropisomeric PCBs to distinguish fresh versus aged sources. They found that whereas air samples at one urban and one rural location in the West Midlands, UK, had racemic signatures of PCBs 95, 136 and 149 and their congener profiles resembled those of the technical formulations, paired samples from top soil showed enantiomeric degradation. Harrad and co-workers followed this study with a more extensive study of 10 sites along an 80 km transect in the West Midlands (Jamshidi *et al.*, 2007). They confirmed the racemic signature in outdoor air that they matched with 20 indoor air samples, but not soil samples taken along the same transect. These results provided strong evidence of indoor air with its fresh PCB signatures as the source to outdoors, rather than the release of aged PCBs from soils.

Asher *et al.* (2007) reported racemic air signatures of PCBs 91, 95, 136 and 149 in the New York/New Jersey Harbor Estuary, which is consistent with fresh emissions. However, they measured nonracemic signatures in water, total suspended particles, phytoplankton and sediment of the harbour. Accordingly, they inferred that PCB contributions from the

Upper Hudson River watershed dominated the PCBs in the aquatic system rather than atmospheric deposition from the immediate urban area.

Leone *et al.* (2000) and Offenberg *et al.* (2004) reported racemic signatures in air concentrations of *trans*- and *cis*-chlordane in indoor air whereas samples in outdoor air and soils showed enantiomeric degradation, although Gouin *et al.* (2007) found that the pattern was not always consistent with the urban–rural differences. Leone *et al.* (2000) and Offenberg *et al.* (2004) concluded that indoor air was a source of chlordanes to outdoor urban air, which is similar to the conclusion reached by Robson and Harrad (2004) and Jamshidi *et al.* (2007) for PCBs.

Whereas the studies described above have sought to identify the main sources, it is more likely that there are multiple sources of POPs to urban centres, some of which show temperature dependence while others do not. This was the conclusion of Rodenburg and co-workers based on a variety of measurements and statistical methods that they used to study PCBs in the Hudson River estuary and the Philadelphia–Camden region (Totten *et al.*, 2004; Asher *et al.*, 2007; Du and Rodenburg, 2007; Du *et al.*, 2008, 2009).

6.5 Chemical Mixtures in Urban Media

Urban development, including residential development, results in chemical emissions to all media such as air, water and soil. Some activities, such as pesticide application, result in the emission of a simple mixture of compounds. Other activities, such as motor vehicle transportation, emit a complex mixture of organic and inorganic compounds such as PAHs and trace amounts of PCDD/Fs.

Atmospherically derived surface films on impervious surfaces are a complex mixture of predominantly inorganic (e.g. sulfate, nitrate, silicates, metals) and secondarily polar and nonpolar organic compounds (Lam *et al.*, 2005). The organic fraction is largely biogenic in origin, but not surprisingly contains POPs including PAHs, PCBs, PCNs, brominated flame retardants (BFRs), pesticides and metals (Liu, Q. T., *et al.*, 2003a, 2003b; Lam *et al.*, 2005; Butt *et al.*, 2004a; Gingrich *et al.*, 2001). The film is a time-integrated sample of ambient air contaminants from both the gas and particle phases and represents the contents of urban ‘grime’. The film concentrates atmospherically deposited compounds and either facilitates the chemicals’ subsequent re-release to air through volatilization, their release to stormwater through washoff or their degradation (Labencki *et al.*, 2009; Kwamena *et al.*, 2007).

The complex mixture of compounds in stormwater is the result of removal by precipitation from impervious, vegetated and soil surfaces. Stormwater may be viewed as integrating air, terrestrial and water quality. Several authors have compiled lists of chemicals in urban stormwater runoff, the most comprehensive of which is that of Makepeace *et al.* (1995). All classes of compounds are found in stormwater runoff, including high concentrations of nutrients, bacteria and viruses, major cations and anions, and lower concentrations of metals and elements, VOCs, SOCs (including some POPs) and pesticides (Lopes and Bender, 1998; Gromaire-Mertz *et al.*, 1999; Phillips *et al.*, 2000; Lopes and Dionne, 1998; Capel *et al.*, 1997; Sztruhar *et al.*, 1997). Stormwater composition is a function of antecedent dry days over which deposited chemicals accumulate (Characklis and Wiesner, 1997). Because of the numerous sources, the number of chemicals and their concentrations in urban stormwater are often greater than in agricultural runoff.

The high concentrations of numerous chemicals in urban media contribute to complex chemical interactions and transformations within urban chemical mixtures. One example of this complexity is chemical speciation and distribution in stormwater, which affects bioavailability, toxicity and fate. High particle and colloidal concentrations suggest that many compounds in stormwater are not bioavailable, although the extent to which bioavailability is reduced depends on location.

6.6 Fate in Urban Areas

The fate of POPs in urban areas differs from nonurban systems. Firstly, urban areas have large areas of impervious surfaces that increase chemical mobility and transformation rates due to the presence of the film on these surfaces (Priemer and Diamond, 2002; Kwamena *et al.*, 2007). Secondly, the high chemical concentrations in urban media can affect chemical fate through chemical interactions and transformations. Thirdly, the reduced vegetative cover in urban areas results in profoundly different hydrological flows and microclimatic extremes marked by larger volumes of runoff and lower rates of evapotranspiration. Finally, urban warming increases local temperatures above those of surrounding hinterlands (Stone and Rodgers, 2001) and can exacerbate rates of contaminant emission and mobility. The combination of these factors increases chemical mobility in cities versus forested areas (Priemer and Diamond, 2002).

The multimedia urban model (MUM) is a fugacity-based mass balance model that treats the movement of POPs in an urban environment and links emissions to ambient chemical concentrations, and thus outdoor exposure (Diamond *et al.*, 2001). MUM considers long-term, average conditions of chemical transport and transformation among six environmental compartments in urban areas (air, soil, surface water, sediment, vegetation and surface film; see Figure 6.1) shows a conceptual version of the model). The model does not estimate event-specific processes as do meteorological-based air or stormwater models.

MUM-Fate includes films on impervious surfaces that link atmospheric emissions and subsequent movement of contaminants to surface water and sediment (Labencki *et al.*, 2009). The model illustrates that surface films can vary from acting as a temporary sink through temperature-dependent condensation of gas-phase POPs to a permanent reactive sink, to a source of POPs through temperature-dependent volatilization (Diamond *et al.*, 2001; Kwamena *et al.*, 2007). The exact role played by the film is a function of the physical–chemical properties of the particular compound, as illustrated in Figure 6.2, which was generated by varying the octanol–air partition coefficient of a PCB-like compound while assuming no degradation. This analysis shows the interplay between losses due to volatilization versus washoff and that the proportions shift according to ambient temperature, i.e. colder temperatures promote condensation and greater loss from washoff in contrast to warmer temperatures that favour loss due to volatilization (as modified from Priemer and Diamond, 2002).

For photoreactive compounds such as PAHs, reaction in surface films can be their main degradative loss process in an urban system. Kwamena *et al.* (2004) and Poschl *et al.* (2001) found under experimental conditions that reactions of PAHs on organic-coated films exceeded those on atmospheric particulate matter (PM), the reason for which was not clear. Using these experimentally derived reaction rates in MUM, Kwamena *et al.* (2007)

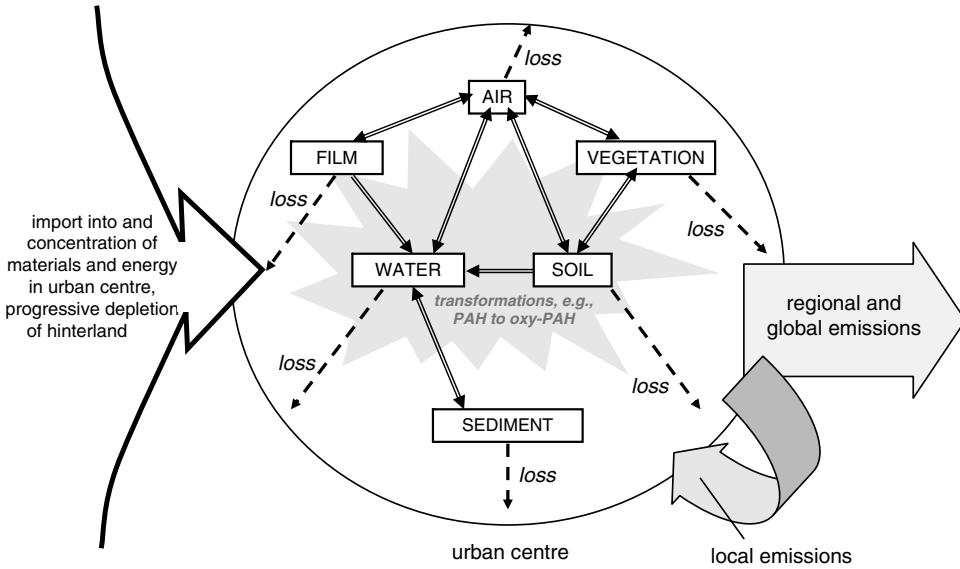

Figure 6.1 Conceptual model derived from the multimedia urban model (MUM) of contaminant emissions, transformation and transport in and from urban areas

found that advection by air was by far the dominant loss process from an urban centre for PAHs anthracene (found mostly in air), pyrene (distributed among air, film and soil) and benzo[*a*]pyrene (BaP, mostly in soil) (Figure 6.3). The next greatest loss process was the gas-phase reaction with OH of anthracene and pyrene, and the reaction in surface films of

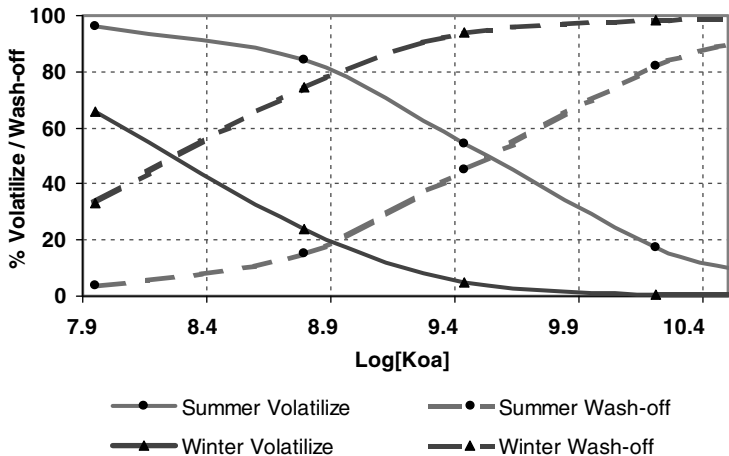

Figure 6.2 The relationship between percentage loss of a nonreactive POP to volatilization versus washoff from surface film as a function of K_{OA} calculated using MUM-Fate. Summer and winter conditions were estimated assuming 25 and 5 °C, respectively

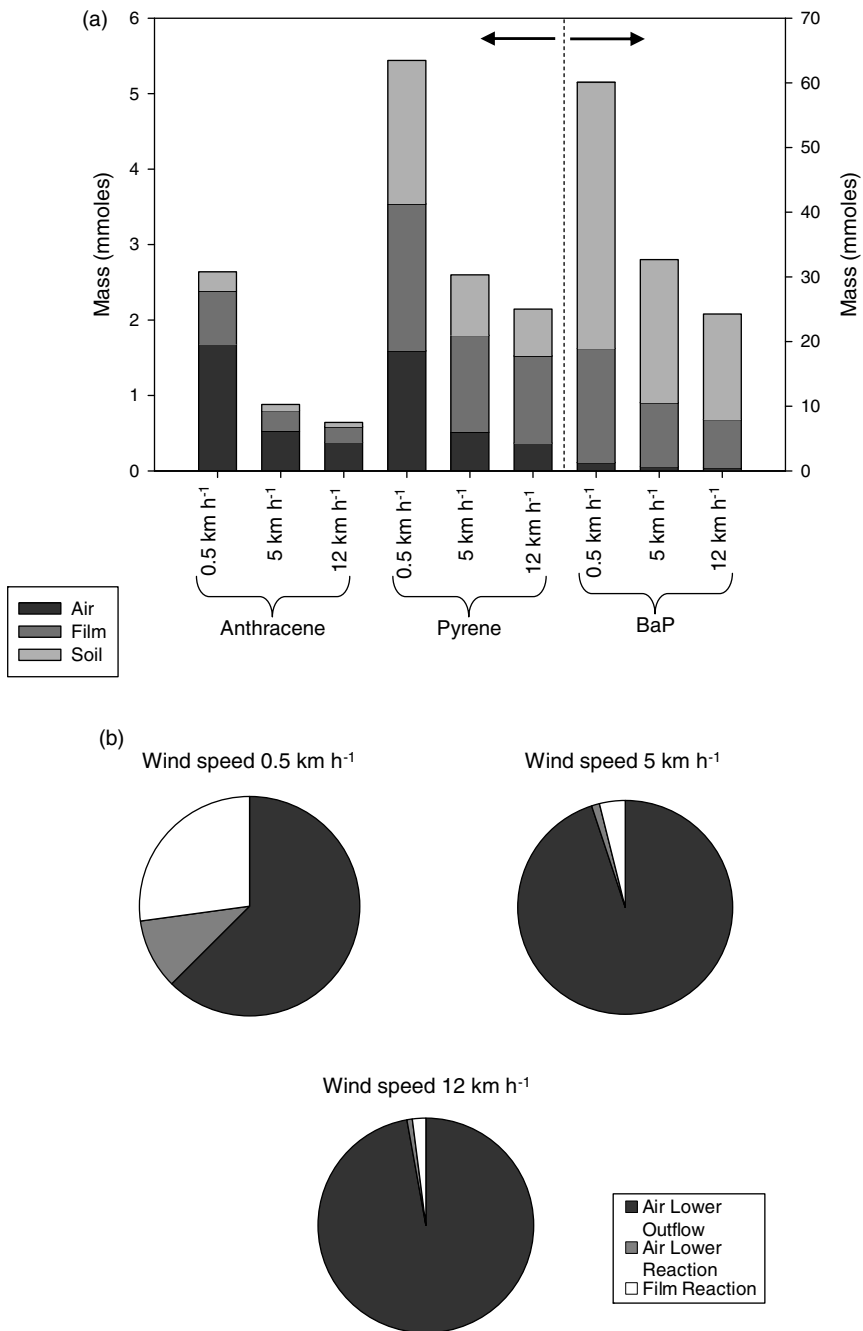

Figure 6.3 The fate of reactive chemicals anthracene, pyrene and benzo[a]pyrene in an urban environment. (a) The mass distribution of anthracene, pyrene and benzo[a]pyrene considering three wind speeds and (b) percentage losses due to advection and reaction of benzo[a]pyrene at three wind speeds. (Reproduced with permission from Kwamena et al., © 2007 Elsevier)

BaP. The importance of reaction losses in film for only BaP (and other low-volatility, high molecular weight PAHs) was ascribed to its tendency to partition into condensed phases (e.g. soil, PM, film), an order of magnitude greater ratio of surface area to volume of films on impervious surfaces (10^6) versus surface films on PM (10^5), and least important, the faster reaction rate in film versus PM.

For PCBs and PBDEs, the consequence of urban emissions and fate for human exposure and potential risk does not come from exposure to outdoor urban air, soils or surface waters. Rather, the main exposure route for PCBs and PBDEs is either indoor air or dust, or diet where fish have particularly high concentrations (see Chapter 8). The connection between PCBs and PBDEs in food and their emission from an urban area can again be clarified by examining the output from MUM. More than 90% of PCB and PBDE emissions within the urban area, plus inputs from regional atmospheric transport, is advected downwind from the city (Figure 6.4). These downwind locations include agricultural areas where, through atmospheric deposition to crops, the compounds move through the terrestrial food web and return to us in our foods from animal products (Harrad and Diamond, 2006; see Chapter 8). For cities located on waterbodies, downwind advection of the contaminant mass may translate to atmospheric deposition to the lakes (e.g. Offenberg and Baker, 1997; Simcik *et al.*, 1997; Totten *et al.*, 2004). Most of the remaining < 10% of total emissions from the city enters surface water. Although some of this chemical mass will be removed by wastewater treatment systems, a fraction is discharged and is then available for bioconcentration and biomagnification through the aquatic food web. This passage of persistent chemicals from point of emission (e.g. PCBs evaporating from an in-use light ballast), through the city, and either atmospheric deposition directly to surface waters or discharge via stormwater, and finally incorporation in the aquatic food web, in part explains elevated concentrations of PCBs in fish from nearly all nearshore areas of Lake Ontario (*Guide to Eating Ontario Sport Fish*, 2006).

6.7 Emissions and Environmental Degradation

It is difficult to tease apart the individual contributions of chemical emissions to the degradation of urban ecosystems versus other perturbations such as those to hydrologic regimes, micro- and mesoclimate, soil structure and species composition brought about by the introduction of many exotic species. In fact, negative impacts are usually related to a combination of stresses. One disturbance can reduce the resilience of organisms to subsequent stresses, e.g. increased susceptibility of fish to infectious disease following exposure to contaminants from stormwater discharges (Arkoosh *et al.*, 2001). This section discusses some of the numerous examples of environmental degradation resulting from widespread urban chemical release to soil, surface water, sediments, groundwater and air.

Contamination of urban soils by POPs such as PCBs is of concern for human and ecological health. Soil contamination by metals and persistent organics disrupts nutrient cycling and is associated with declines in density of soil microfauna and lower rates of decomposition of organic compounds (Carreiro *et al.*, 1999; Pouyat *et al.*, 1994), an important process for the removal of organic contaminants from the environment. Ironically, urban warming may counteract this effect in some locations (McDonnell *et al.*, 1997).

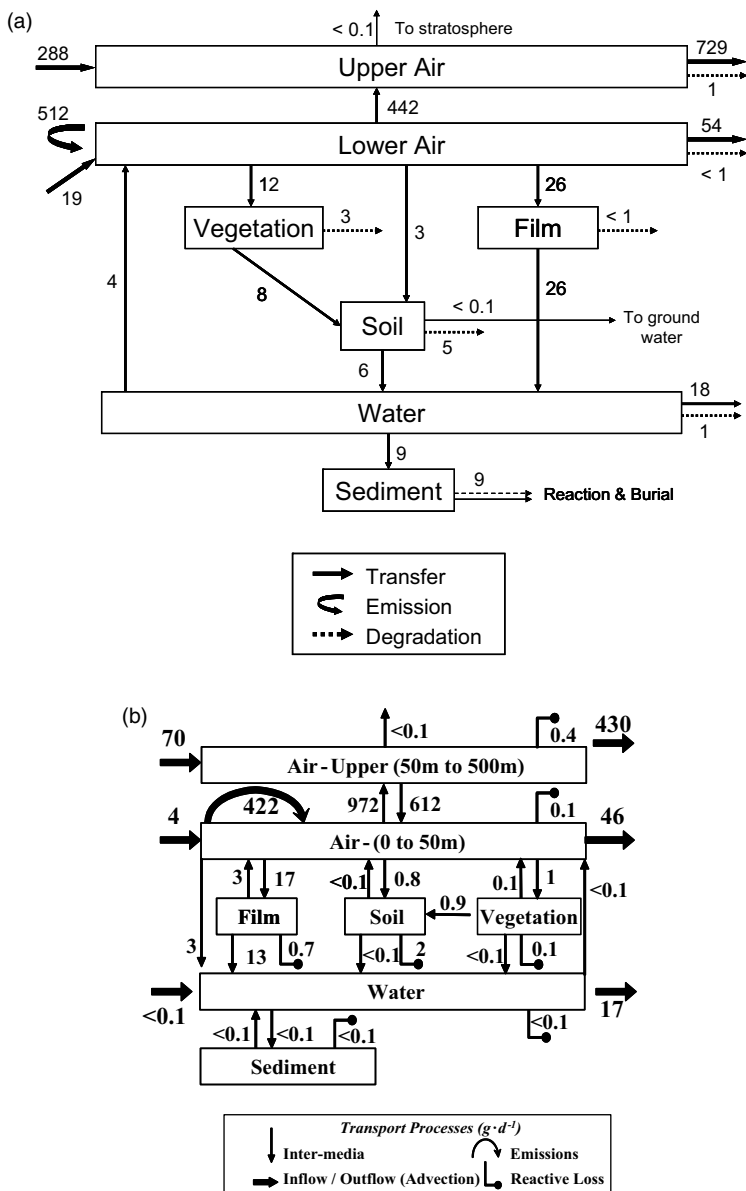

Figure 6.4 Estimated emissions and fate of two POPs in Toronto, Canada. (a) Σ PCBs (CB-28, 52, 101, 153, 180) (Reproduced with permission from Diamond et al., © (2009) American Chemical Society) and (b) Σ PBDEs (BDE-17, 28, 47, 66, 77, 85, 99, 100, 126, 153, 154, 183) (Reproduced with permission from Jones-Otazo et al., © (2005) American Chemical Society)

Loadings of PAHs and other POPs occur to surface waters near urban areas via atmospheric deposition, direct discharge and runoff (Offenberg and Baker, 1997; Bamford *et al.*, 1999; Zhang *et al.*, 1999; Gigliotti *et al.*, 2005). Since urban runoff contains a complex mixture of contaminants, some of which are found at relatively high concentrations (Makepeace *et al.*, 1995), its discharge degrades nearshore environments (Carr *et al.*, 2000; Cross and Hose, 1988). For example, concentrations in aquatic biota of halogenated organic contaminants and metals generally increase with increasing proximity to urban areas (Giesy and Kannan, 2001; Johnson and Olson, 2001; Wright and Mason, 1999), as do an array of sublethal abnormalities, reproductive impairments and neoplasms in a variety of fish and invertebrate species (Gagnon and Holdway, 2002; Matthiessen and Law, 2002; Sepulveda *et al.*, 2002; Mikaelian *et al.*, 2000).

Attempts to reduce the impacts of urban areas on aquatic biota have involved examining the relationship between the percentage of impervious cover versus various biological assessment indices, and has led to the conclusion that the percentage of impervious cover must not exceed 15% to protect stream integrity (Roesner *et al.*, 2001). Schueler *et al.* (1992) have shown that impervious surface coverage in urban areas is inversely related to the health of aquatic biota in surface waters, though the precise mechanisms underlying this association are debated because ecosystem degradation downstream from urban areas that conform to the 15% rule still occurs (Roesner *et al.*, 2001). However, we submit that greater protection of stream biota can be achieved by increasing urban density, which entails increased impervious cover but which decreases the total land area devoted to urban development and hence the total mass of emissions, rather than promoting low-density development over larger areas (Jacob and Lopez, 2009).

6.8 Urban Form and Chemical Emissions

As discussed in Section 6.2, demographic factors and factors related to urban form influence the profile and quantities of chemical emissions in urban areas. For example, increasing urban populations combined with increasing separate household numbers have increased the rates and quantities of material and energy consumption and ensuing chemical emissions in urban areas (Liu, J. G., *et al.*, 2003). A second example is the influence of urban sprawl and use of public transit on VKT and associated vehicular emissions (e.g. US EPA, 2004; Lyons *et al.*, 1990). Sprawled patterns of development also exacerbate urban warming (Stone and Rodgers, 2001). Higher air temperatures increase energy consumption and ensuing chemical emissions by increasing demand for air conditioning and by increasing volatilization of POPs from contaminated materials such as electrical transformers and building materials. This section examines three aspects of the relationship between urban form and chemical emissions in urban areas: urban sprawl and emissions from motor vehicles; the relationship between urban sprawl, urban warming and chemical dynamics in urban areas; and trends in stormwater management. We include a discussion of vehicles because of their emissions of PAHs and PCDD/Fs (Dyke *et al.*, 2007).

6.8.1 Transportation, Urban Sprawl and Emissions

Urban form, including such aspects as transportation infrastructure, influences traffic congestion and the number and length of passenger car trips taken in a city, thereby

influencing contaminant emissions associated with motor vehicle use. The predominant pattern in North American urbanization over recent decades, one where rates of conversion of land for urban uses has exceeded the rate of population growth (Sorensen *et al.* 1997), is commonly termed 'urban sprawl'. As cities have sprawled and as private vehicles rather than public transit have been adopted as the major mode of travel, the VKT *per capita* has increased as well (US EPA, 2004). Increases in VKT are closely associated with concurrent increases over time in the levels of PAH contamination of sediments in urban watersheds (Donaghy and Schintler, 1998; Van Metre *et al.*, 2000).

With respect to VKT and vehicular emissions, the absolute size or population density of an urban area is not as important as other factors, including provision and rates of use of public transit, access to other modes of travel, such as walking, and the specific arrangement in space of residential, industrial, commercial and recreational functions in relation to one another (Lyons *et al.*, 1990; Badoe and Miller, 2000; Ewing *et al.*, 2002). Frank *et al.* (2000), in their study of vehicle use in the Seattle area, found that emissions due to household vehicles are inversely related to street connectivity and work tract employment density, in addition to household density. The feasibility of reducing VKT by providing mass transit is also affected by urban form, as demonstrated by recent work by Gilbert (2002), who found that 2 million people in the Greater Toronto Area (GTA) live in areas too scattered to permit the operation of an efficient, tethered transit system.

Mandated requirements regarding the control of vehicular emissions can lead to planning decisions that ensure compliance (e.g. vehicle emission testing) but do not address the origins of increased requirements for passenger car trips, e.g. road improvements versus re-zoning to permit mixed land uses (Frank *et al.*, 2000). Misconceptions regarding the origin of sprawl also contribute to the continuing widespread approval of development projects that exacerbate it (Bourne, 2001). The most commonly villified image of urban sprawl is a residential cul-de-sac of single-family homes with wide expanses of green lawn. In fact, decreasing suburban densities are not primarily driven by the residential sector, but by low-density, nonresidential uses such as commercial, industrial, distributional and recreational activities (Bourne, 2001).

Energy use may be used as a proxy for chemical emissions attributable to transportation. Gilbert (2002) has linked higher *per capita* energy use to declining rates of automobile occupancy and transit use in the Greater Toronto Area (GTA). Gilbert also found that energy use in Ontario between 1990 and 1999 was virtually static in the residential and industrial sectors while it increased by 23% each in the transportation and commercial/retail sector. The largest portion of the increase in transportation energy use was in freighting; the increase in energy use by passenger car travel was in fact below the rate of population growth due to improved combustion efficiencies (Gilbert, 2002). Sahely *et al.* (2003), who examined the urban metabolism of the GTA, found that from 1987 to 1999 gasoline and diesel use increased by 27 and 67% respectively, the latter being significantly in excess of population growth over the same period. The larger increase in diesel than gas consumption in the GTA has implications for chemical emissions because diesel trucks emit approximately four times more particle-associated polycyclic organic matter (POM) and twice as much PCDD/Fs than catalyst-equipped gasoline vehicles (Rogge *et al.*, 1993a; US EPA, 1998; Chang *et al.*, 2004). POM includes PAHs as well as aza-, carbonyl- and imino-arenes, trace levels of PCDD/Fs and other toxic compounds (US EPA, 1998).

6.8.2 Residential Density and Urban Heat Islands

The urban heat island effect has implications for chemical emissions in several ways. Elevated temperatures increase the consumption of energy for air conditioning and other cooling systems, with attendant increases in fossil fuel combustion-related contaminants (Cardelino *et al.*, 2001; Adams, 1999). Increased ambient air temperatures also increase volatilization of POPs such as PCBs, PCNs and PBDEs from urban sources (Priemer and Diamond, 2002; Helm and Bidleman, 2003).

The relationship between residential density and the urban heat island effect has been recently investigated by Stone and Rodgers (2001). Observing that in Atlanta, Georgia, ambient air temperatures in the 'hot-spot' of the city centre were of equal magnitude to a hot-spot in a suburban county, the authors investigated whether a link could be established between urban form and the magnitude of an urban heat island. In comparing the net thermal emissions (radiant heat flux corrected for the radiant flux estimated to be generated by a forested parcel of equal size) of single-family parcels, they found that expansive forms of residential development emit more excess radiant heat energy *per parcel* than denser, more compact residential development. They found that the quantity of land devoted to lawns and landscaping, rather than the paved and shingled area, was most strongly related to excess heat production in residential development in Atlanta. Although this may seem counterintuitive, as vegetation itself mitigates urban warming, larger suburban lots, despite their larger gardens, have a greater uncanopied area as well. The effect, in absolute terms, is to increase the excess radiant heat energy emitted per single-family unit.

6.8.3 Trends in Stormwater Management

Stormwater runoff is a significant challenge for managing urban chemical emissions and their environmental impacts. In city cores, stormwater can empty untreated into surface waters via combined sewer overflows, infiltrate soil and/or groundwater, and/or enter WWTPs with sewage where it is treated before being discharged. In more recently urbanized areas that are built at lower densities, the high cost of constructing centralized treatment facilities, combined with a desire to reduce the negative impacts on surface water of stormwater, have led to the use of stormwater management practices such as wet and dry detention ponds, otherwise termed stormwater management (SWM) ponds.

SWM ponds are an improvement over past practices where stormwater entered surface and/or groundwaters unchecked. SWM ponds retain coarse suspended solids and a fraction of organic compounds (e.g. PAHs) and metals, thereby preventing their entering surface and groundwater. Fine particles and their associated chemicals, as well as dissolved and colloidal phase compounds, are not well retained by the ponds (VanBuren *et al.*, 1996; Marsalek *et al.*, 1997). Thus, SWM ponds retain, but do not remediate, most contaminants and nutrients associated with stormwater. Unfortunately, there is a tendency to overrate the utility of SWM ponds in development applications and to ignore the exposure of biota to the contaminants trapped in the ponds, and to even include the ponds in development proposals as integral parts of 'ecological corridors' to satisfy regulatory requirements (Diamond *et al.*, 2002).

One objective of best management practices (BMPs) for stormwater is to reduce water volumes and attendant chemical loads by promoting localized management. These BMPs, such as those promoting lot- and subdivision-scale infiltration, are principally based on water management. Since stormwater quality diminishes with increasing impervious surface coverage (Schueler, 1994), some of the management guidance could promote low-density development. These approaches do not account for the fact that stormwater concentrations from high-density developments are lower on a *per capita* basis than those from low-density developments (GHK International *et al.*, 2003; Jacob and Lopez, 2009), nor does simply limiting impervious surface area, without enacting other ameliorative measures, necessarily prevent downstream impacts on aquatic ecosystems (Roesner *et al.*, 2001).

SWM ponds and other decentralized methods of stormwater management are predicated on dilution and the assimilative capacity of the environment rather than on efficient chemical treatment, and illustrate several issues confronting planners and policy makers with regards to urban chemical emissions. Measures directed at containment alone *defer*, rather than eliminate, a possible future need to remediate the contaminants considered. Stormwater management that is based on geographically dispersed and unmonitored collection ponds may be the basis of a future problem of localized hot-spots of soil and sediment contamination, particularly if and where some contemporary suburbs become economic foci and subsequent infilling leads to higher population densities and more intense land use. The hazards of such a scenario are amply demonstrated by cases where past industrial or municipal landfill sites were unwittingly or irresponsibly redeveloped as residential subdivisions, leading to human exposures to the contaminant mixtures present at the sites and costly remediation (International Institute of Concern for Public Health, 1998).

6.9 Future Directions

The hazards posed by urban environmental contaminants are not, of course, the only ones posed to ecological and human health. Climate change, access to health care, the provision and maintenance of sanitary and other infrastructure, and numerous other economic and political factors variously impact on ecological and human health in cities. By some measures, and in some locations, urbanites enjoy better health and well-being than their rural counterparts, a difference thought to be due to socioeconomic factors, and access to health care and other social institutions (Perdue *et al.*, 2003). Policies to address urban environmental health may be debated within a benefit-risk framework that considers the multiplicity of economic, social and environmental factors that interact and underlie health and well-being.

Nevertheless, urban contaminant emissions contribute to significant environmental degradation and, at least, urban air pollution, including PAHs, are linked to human health effects (e.g. Cohen *et al.*, 2005; Perera *et al.*, 2006). Evidence is emerging of the connection between POP exposure and diabetes (Carpenter, 2008; Codru *et al.*, 2007), as well as exposure to air pollution and diabetes (e.g. Brook *et al.*, 2008). However, whether the POP–diabetes correlation is exacerbated by urban exposure pathways is not known. With that larger perspective in mind, what are some of the main gaps in our scientific understanding of contaminant dynamics in urban areas and what types of questions might science address in the near future?

6.9.1 Quantifying Rates of Emission

In contrast to studies of ambient contaminant concentrations in urban areas, comparatively little work has determined rates of contaminant emissions, with the exception of PCBs (e.g. Offenberg *et al.*, 2005; Totten *et al.*, 2006; Gasic *et al.*, 2009). This information is of critical importance to risk assessment studies and the design of effective policies and programmes aimed at emissions reductions. There are numerous examples of national scale emissions inventories of single-chemical or point-source. These do not account for many of the important non-point sources of contaminants in urban areas, nor are they comparable due to differences in categorization and research priorities in different jurisdictions (Seika *et al.*, 1996).

6.9.2 Influence of Urban Areas on Chemical Fate

There are many unanswered questions regarding chemical interactions and fate processes. What is the composition and impact of chemical interactions given the complex mixture of chemicals emitted and found in urban matrices (e.g. enhanced rates of chemical reaction and a wider range of transformation products)? What are the roles of urban form and management practices in mediating transport dynamics (e.g. the implications of stormwater management systems on total chemical fate)? Furthermore, what role do different types of urban development patterns and heat island effects play with respect to contaminant fate? Does the simplified vegetative community that is dominated by exotic species influence the rate at which chemicals are 'processed' or accumulated?

6.9.3 Economic Activity, Urban Form and Chemical Emissions

How does the socioeconomic geography of cities affect chemical emissions? A case in point is the deindustrialization of Western cities in favour of a service-based economy (Salzman, 1999), which has contributed to a change in the profile of the sources, types and rates of urban chemical emissions. What are the implications of the so-called 'service-based economy' in HICs for patterns and rates of chemical emissions? What are the implications of chemical production, product manufacturing, etc., in emerging economies or LIC? Similarly, as patterns of consumption and technologies have changed, new considerations such as the overwhelming volume of waste electronic and electrical equipment (WEEE) emanating from cities have emerged (see also Chapters 5 and 8).

The literature does suggest that dense urban form provides opportunities to reduce *per capita* emissions. The opportunity arises because, for example, (1) lower material and energy inputs for infrastructure are necessary to support each resident than with low-density development (hence a lower *per capita* stock of building materials and their associated emissions), (2) transportation-related emissions can be reduced by the provision of affordable mass transit (mass transit for low-density developments is difficult to finance) and (3) centralized waste management and treatment also becomes more economically efficient and feasible.

6.9.4 From Dilution to Reduction

There is a need within environmental research to recognize that there are no perfect measures for containment and remediation of contaminants associated with human settlement, whether in soil, water or air quality. There probably never will be perfect measures,

given the material basis of urban settlements: the importing of resources and energy from a wide area and the subsequent storage of materials and discharging of wastes into the comparatively confined area of a city. The implicit assumption that development can occur with minimal impacts underlies mandated measures such as riverine setbacks and some stormwater management strategies that rely on dilution and the environment's assimilative capacity rather than on emission reduction and treatment. However, these well-intentioned measures that result in certain environmental benefits may also contribute to or justify urban sprawl (Bourne, 2001; Jackson, 2003), which tends to contribute to greater overall chemical emissions in the North American context. At a local level, arguments over urban development, based on concerns about environmental impacts, tend to focus on debating the merits of different options for environmental remediation or the control of emissions. Arguments framed in this way tend to leave equally valuable questions unasked. For example, what types of urban form are commensurate with the lowest *per capita* emission rates of various contaminants? How can the relationship between rates of material and energy use and emissions of different contaminants be quantified in order to strategize to minimize emissions? Following from this, what combinations of economic, cultural and physical factors contribute to lower rates of material and energy consumption?

Ultimately, whatever environmental and planning measures are chosen, some degree of environmental degradation is inevitable in urban areas and, to a greater or lesser extent, in surrounding areas as well. Nevertheless, the impact that urban areas have on regional environmental quality and the quality of our food supply, the established trend of rapid urban metropolitan growth (in both population and area) and prevailing high rates of resource consumption all warrant deliberate efforts at mitigating the environmental effects of urban areas.

Acknowledgements

This chapter is dedicated to Anne Motelay-Massei who made important contributions to our understanding of urban contaminant issues in her life, which was far too short. The authors are grateful for funding from Great Lakes Corporate Policy, Environment Canada, Premier's Research Excellence Award to M. Diamond, NSERC Strategic Grant to M. Diamond, T. Harner and B. Branfireun, and student support from University of Toronto, Centre for Global Change. Carolyn O'Neill and Heather Morrison, Environment Canada, kindly reviewed an earlier draft (O'Neill is now at Ontario Ministry of Environment). Kate Liss and Amanda Giang contributed to final revisions.

References

- Abdallah, M. A. E., Harrad, S., *et al.* (2008) Hexabromocyclododecanes and tetrabromobisphenol-A in indoor air and dust in Birmingham, UK: implications for human exposure. *Environmental Science and Technology*, **42**(18): 6855–6861.
- Adams, E. (1999) Urban heat (an evaluation of infrared photography that shows how buildings contribute to hot pockets in cities). *Architecture*, **88**(1): 134–135.
- Alderson, A.S. (1999) Explaining deindustrialization: globalization, failure, or success? *American Sociological Review*, **64**(5): 701–721.

- Ansari, M.I. (1992) Growth effects of recent structural-changes in the Canadian economy – some empirical-evidence. *Applied Economics*, **24**(11): 1233–1240.
- Arkoosh, M.R., Clemons, E., *et al.* (2001) Increased susceptibility of juvenile Chinook salmon to vibriosis after exposure to chlorinated and aromatic compounds found in contaminated urban estuaries. *Journal of Aquatic Animal Health*, **13**(3): 257–268.
- Asher, B.J., Wong, C.S., *et al.* (2007) Chiral source apportionment of polychlorinated biphenyls to the Hudson River estuary atmosphere and food web. *Environmental Science and Technology*, **41**(17): 6163–6169.
- Badoe, D.A., Miller, E.J. (2000) Transportation–land-use interaction: empirical findings in North America, and their implications for modeling. *Transportation Research Part D –Transport and Environment*, **5**(4): 235–263.
- Bamford, H.A., Offenberg, J.H., *et al.* (1999) Diffusive exchange of polycyclic aromatic hydrocarbons across the air–water interface of the Patapsco River, an urbanized subestuary of the Chesapeake Bay. *Environmental Science and Technology*, **33**(13): 2138–2144.
- Bidleman, T.F., Harner, T., *et al.* (1998) Chiral pesticides as tracers of air–surface exchange. *Environmental Pollution*, **102**(1): 43–49.
- Bjorklund, J.A., Thuresson, K., *et al.* (2009) Perfluoroalkyl compounds (PFCs) in indoor dust: concentrations, human exposure estimates, and sources. *Environmental Science and Technology*, **43**(7): 2276–2281.
- Bourne, L.S. (2001) The urban sprawl debate: myths, realities and hidden agendas. *Plan Canada*, **41**: 26.
- Brook, J.R., Lillyman, C.D., *et al.* (2002) Regional transport and urban contributions to fine particle concentrations in southeastern Canada. *Journal of the Air and Waste Management Association*, **52**(7): 855–866.
- Brook, R.D., Jerreft, M., *et al.* (2008) The relationship between diabetes mellitus and traffic-related air pollution. *Journal of Occupational and Environmental Medicine*, **50**(1): 32–38.
- Bruniak, P.A., Dachs, J., *et al.* (2001) Atmospheric polychlorinated biphenyl concentrations and apparent degradation in coastal New Jersey. *Atmospheric Environment*, **35**(19): 3325–3339.
- Brunner, P., Rechberger, H. H. (2001) Anthropogenic metabolism and environmental legacies. In *Encyclopedia of Global Environmental Change* (ed. T. Munn). John Wiley & Sons, Ltd, Chichester, UK.
- Butt, C.M., Diamond, M.L., *et al.* (2004a) Spatial distribution of polybrominated diphenyl ethers in southern Ontario as measured in indoor and outdoor window organic films. *Environmental Science and Technology*, **38**(3): 724–731.
- Butt, C.M., Diamond, M.L., *et al.* (2004b) Semivolatile organic compounds in window films from lower Manhattan after the September 11th World Trade Center attacks. *Environmental Science and Technology*, **38**(13): 3514–3524.
- Butt, C. M., Diamond, M. L., Truong, J., Ikonou, M. G., Mortimer, W. (2009) Polychlorinated dibenzodioxins and furans from uncontrolled burning of garbage in a remote community and comparison with urban–rural locations in Toronto, Canada. *Environmental Ecotox Safety*, (submitted).
- Cameron, I., Lyons, T.J., *et al.* (2004) Trends in vehicle kilometres of travel in world cities, 1960–1990: underlying drivers and policy responses. *Transportation Policy*, **11**: 287.
- Capel, P. D., Lin, M., *et al.* (1997) Wet atmospheric deposition of pesticides in Minnesota, 1985–94. *US GS Water Research Investment*, WRI 97-4206.
- Capuano, F., Cavalchi, B., *et al.* (2005) Environmental prospection for PCDD/PCDF, PAH, PCB and heavy metals around the incinerator power plant of Reggio Emilia town (Northern Italy) and surrounding main roads. *Chemosphere*, **58**(11): 1563–1569.
- Cardelino, C.A., Chamedies, W.L., *et al.* (2001) Urban form and thermal efficiency. *Journal of American Planning Association*, **67**: 187.
- Carpenter, D.O. (2008) Environmental contaminants as risk factors for developing diabetes. *Reviews on Environmental Health*, **23**(1): 59–74.
- Carr, R.S., Montagna, P.A., *et al.* (2000) Impact of storm-water outfalls on sediment quality in Corpus Christi Bay, Texas, USA. *Environmental Toxicology and Chemistry*, **19**(3): 561–574.
- Carreiro, M.M., Howe, K., *et al.* (1999) Variation in quality and decomposability of red oak leaf litter along an urban–rural gradient. *Biology and Fertility of Soils*, **30**(3): 258–268.

- Chang, M.B., Chang, S.H., *et al.* (2004) Dioxin emission factors for automobiles from tunnel air sampling in Northern Taiwan. *Science of the Total Environment*, **325**(1–3): 129–138.
- Characklis, G.W., Wiesner, M.R. (1997) Particles, metals, and water quality in runoff from large urban watershed. *Journal of Environmental Engineering – ASCE*, **123**(8): 753–759.
- Clarke, J. P., Diamond, M. L., *et al.* (in prep.) Modelling emissions and fate of PCBs in an urban area.
- Codru, N., Schymura, M.J., *et al.* (2007) Diabetes and relation to serum levels of polychlorinated biphenyls and chlorinated pesticides an adult native Americans. *Environmental Health Perspectives*, **115**: 1442–1447.
- Cohen, A.J., Anderson, H.R., *et al.* (2005) The global burden of disease due to outdoor air pollution. *Journal of Toxicology and Environmental Health – Part A – Current Issues*, **68**(13–14): 1301–1307.
- Cotham, W.E., Bidleman, T.F. (1995) Polycyclic aromatic-hydrocarbons and polychlorinated-biphenyls in air at an urban and a rural site near Lake Michigan. *Environmental Science and Technology*, **29**(11): 2782–2789.
- Covaci, A., Hura, C., *et al.* (2001) Selected persistent organochlorine pollutants in Romania. *Science of the Total Environment*, **280**(1–3): 143–152.
- Covaci, A., Gerecke, A.C., *et al.* (2006) Hexabromocyclododecanes (HBCDs) in the environment and humans: a review. *Environmental Science and Technology*, **40**(12): 3679–3688.
- Covaci, A., Voorspoels, S., *et al.* (2009) Analytical and environmental aspects of the flame retardant tetrabromobisphenol-A and its derivatives. *Journal of Chromatography A*, **1216**(3): 346–363.
- Cross, J.N., Hose, J.E. (1988) Evidence for impaired reproduction in white croaker (*Genyonemus lineatus*) from contaminated areas off Southern California. *Marine Environmental Research*, **24**(1–4): 185–188.
- D'Eon, J.C., Crozier, P.W., *et al.* (2009) Observation of a commercial fluorinated material, the polyfluoroalkyl phosphoric acid diesters, in human sera, wastewater treatment plant sludge, and paper fibers. *Environmental Science and Technology*, **43**(12): 4589–4594.
- Diamond, M.L., Hodge, E. (2007) Urban contaminant dynamics: from source to effect. *Environmental Science and Technology*, **41**(11): 3796–3800.
- Diamond, M.L., Priemer, D.A., *et al.* (2001) Developing a multimedia model of chemical dynamics in an urban area. *Chemosphere*, **44**(7): 1655–1667.
- Diamond, M. L., Helferty, N., *et al.* (2002) Natural heritage systems in urbanizing settings – sustainable practices for the Oak Ridges Moraine, Toronto. Prepared on behalf of Save the Rouge Valley System Inc. and the City of Toronto.
- Diamond, M. L., Melymuk, L., *et al.* (2009) Are PCBs legacy contaminants? (submitted).
- Donaghy, K.P., Schintler, L.A. (1998) Managing congestion, pollution, and pavement conditions in a dynamic transportation network model. *Transportation Research Part D – Transport and Environment*, **3**(2): 59–80.
- Douglas, I., Hodgson, R., *et al.* (2002) Industry, environment and health through 200 years in Manchester. *Ecological Economics*, **41**(2): 235–255.
- Du, S.Y., Rodenburg, L.A. (2007) Source identification of atmospheric PCBs in Philadelphia/Camden using positive matrix factorization followed by the potential source contribution function. *Atmospheric Environment*, **41**(38): 8596–8608.
- Du, S., Belton, T.J., *et al.* (2008) Source apportionment of polychlorinated biphenyls in the tidal Delaware River. *Environmental Science and Technology*, **42**(11): 4044–4051.
- Du, S., Wall, S.J., *et al.* (2009) Passive air sampling for polychlorinated biphenyls in the Philadelphia Metropolitan Area. *Environmental Science and Technology*, **43**(5): 1287–1292.
- Dyke, P.H., Sutton, M., *et al.* (2007) Investigations on the effect of chlorine in lubricating oil and the presence of a diesel oxidation catalyst on PCDD/F releases from an internal combustion engine. *Chemosphere*, **67**(7): 1275–1286.
- Edwards, R.D., Jurvelin, J., *et al.* (2001) VOC source identification from personal and residential indoor, outdoor and workplace microenvironment samples in EXPOLIS – Helsinki, Finland. *Atmospheric Environment*, **35**(28): 4829–4841.
- Eisenreich, S. J. (2000) Polychlorinated biphenyl emissions to urban atmospheres: enhanced concentrations, atmospheric dynamics and controlling processes. In International Joint Commission Workshop, Milwaukee, Wisconsin, 2000.

- Ellis, D.A., Mabury, S.A., *et al.* (2001) Thermolysis of fluoropolymers as a potential source of halogenated organic acids in the environment. *Nature*, **412**(6844): 321–324.
- Ewing, R., Pendall, R., *et al.* (2002) *Measuring sprawl and its impact*. Smart Growth America, Washington, DC.
- Farrar, N.J., Harner, T., *et al.* (2004a) Field deployment of thin film passive air samplers for persistent organic pollutants: a study in the urban atmospheric boundary layer. *Environmental Science and Technology*, **39**(1): 42–48.
- Farrar, N.J., Smith, K.E.C., *et al.* (2004b) Atmospheric emissions of polybrominated diphenyl ethers and other persistent organic pollutants during a major anthropogenic combustion event. *Environmental Science and Technology*, **38**(6): 1681–1685.
- Foster, G.D., Roberts, E.C., *et al.* (2000) Hydrogeochemistry and transport of organic contaminants in an urban watershed of Chesapeake Bay (USA). *Applied Geochemistry*, **15**(7): 901–915.
- Frank, L.D., Stone, B., *et al.* (2000) Linking land use with household vehicle emissions in the central puget sound: methodological framework and findings. *Transportation Research Part D—Transport and Environment*, **5**(3): 173–196.
- Fromme, H., Tittlemier, S.A., *et al.* (2009) Perfluorinated compounds – exposure assessment for the general population in Western countries. *International Journal of Hygiene and Environmental Health*, **212**(3): 239–270.
- Gagnon, M.M., Holdway, D.A. (2002) EROD activity, serum SDH and PAH biliary metabolites in sand flathead (*Platycephalus bassensis*) collected in Port Phillip Bay, Australia. *Marine Pollution Bulletin*, **44**(3): 230–237.
- Garban, B., Blanchoud, H., *et al.* (2002) Atmospheric bulk deposition of PAHs onto France: trends from urban to remote sites. *Atmospheric Environment*, **36**(34): 5395–5403.
- Gasic, B., Moeckel, C., *et al.* (2009) Measuring and modeling short-term variability of PCBs in air and characterization of urban source strength in Zurich, Switzerland. *Environmental Science and Technology*, **43**(3): 769–776.
- Gearhart, J., Posselt, H. (2006) Toxic at any speed: chemicals in cars and the need for safer alternatives. The Ecology Center, Ann Arbor, Michigan.
- GHK International, Diamond, M. L., *et al.* (2003) Forecast and analysis of urban development in the Great Lakes Basin. Prepared for Scientific Subcommittee of the International Joint Commission, GHK International.
- Giesy, J.P., Kannan, K. (2001) Global distribution of perfluorooctane sulfonate in wildlife. *Environmental Science and Technology*, **35**(7): 1339–1342.
- Gigliotti, C.L., Totten, L.A., *et al.* (2005) Atmospheric concentrations and deposition of polycyclic aromatic hydrocarbons to the Mid-Atlantic East Coast Region. *Environmental Science and Technology*, **39**(15): 5550–5559.
- Gilbert, R. (2002) The end of cheap energy and the future of the GTA. In Greater Toronto Area Forum, Toronto, Ontario.
- Gingrich, S.E., Diamond, M.L., *et al.* (2001) Atmospherically derived organic surface films along an urban–rural gradient. *Environmental Science and Technology*, **35**(20): 4031–4037.
- Glassmeyer, S. T., Kolpin, D. W., *et al.* (2008) Environmental presence and persistence of pharmaceuticals – an overview. In *Fate of Pharmaceuticals in the Environment and in Water Treatment Systems* (ed. D. S. Aga) CRC Press–Taylor & Francis Group, Boca Raton, Florida, pp. 3–51.
- Golomb, D., Barry, E., *et al.* (2001) Atmospheric deposition of polycyclic aromatic hydrocarbons near New England coastal waters. *Atmospheric Environment*, **35**(36): 6245–6258.
- Gouin, T., Harner, T., *et al.* (2005) Passive and active air samplers as complementary methods for investigating persistent organic pollutants in the Great Lakes basin. *Environmental Science and Technology*, **39**(23): 9115–9122.
- Gouin, T., Jantunen, L., *et al.* (2007) Spatial and temporal trends of chiral organochlorine signatures in Great Lakes air using passive air samplers. *Environmental Science and Technology*, **41**(11): 3877–3883.
- Gromaire-Mertz, M.C., Garnaud, S., *et al.* (1999) Characterisation of urban runoff pollution in Paris. *Water Science and Technology*, **39**(2): 1–8.
- Guide to Eating Ontario Sport Fish* (2005–2006 edition) (2006) Ontario Ministry of the Environment, Etobicoke, Ontario.

- Hafner, W.D., Hites, R.A. (2003) Potential sources pesticides, PCBs, and PAHs to the atmosphere of the Great Lakes. *Environmental Science and Technology*, **37**(17): 3764–3773.
- Hafner, W.D., Carlson, D.L., *et al.* (2005) Influence of local human population on atmospheric polycyclic aromatic hydrocarbon concentrations. *Environmental Science and Technology*, **39**(19): 7374–7379.
- Haggard, B.E., Galloway, J.M., *et al.* (2006) Pharmaceuticals and other organic chemicals in selected north-central and northwestern Arkansas streams. *Journal of Environmental Quality*, **35**(4): 1078–1087.
- Halsall, C.J., Gevao, B., *et al.* (1999) Temperature dependence of PCBs in the UK atmosphere. *Atmospheric Environment*, **33**(4): 541–552.
- Harner, T., Shoeib, M., *et al.* (2004) Using passive air samplers to assess urban–rural trends for persistent organic pollutants. 1. Polychlorinated biphenyls and organochlorine pesticides. *Environmental Science and Technology*, **38**(17): 4474–4483.
- Harner, T., Shoeib, M., *et al.* (2006) Passive sampler derived air concentrations of PBDEs along an urban–rural transect: spatial and temporal trends. *Chemosphere*, **64**(2): 262–267.
- Harrad, S., Diamond, M. (2006) New directions: exposure to polybrominated diphenyl ethers (PBDEs) and polychlorinated biphenyls (PCBs): current and future scenarios. *Atmospheric Environment*, **40**(6): 1187–1188.
- Harrad, S., Hunter, S. (2006) Concentrations of polybrominated diphenyl ethers in air and soil on a rural–urban transect across a major UK conurbation. *Environmental Science and Technology*, **40**(15): 4548–4553.
- Harrad, S., Ibarra, C., *et al.* (2008) Concentrations of brominated flame retardants in dust from United Kingdom cars, homes, and offices: causes of variability and implications for human exposure. *Environment International*, **34**(8): 1170–1175.
- Helm, P.A., Bidleman, T.F. (2003) Current combustion-related sources contribute to polychlorinated naphthalene and dioxin-like polychlorinated biphenyl levels and profiles in air in Toronto, Canada. *Environmental Science and Technology*, **37**(6): 1075–1082.
- Herrick, R.F., McClean, M.D., *et al.* (2004) An unrecognized source of PCB contamination in schools and other buildings. *Environmental Health Perspectives*, **112**(10): 1051–1053.
- Hertwich, E.G., Peters, G.P. (2009) Carbon footprint of nations: a global, trade-linked analysis. *Environmental Science and Technology*.
- Hill, M., Saviello, T., *et al.* (2002) The greening of a pulp and paper mill: International Paper's Androscoggin Mill, Jay, Maine. *Journal of Industrial Ecology*, **6**: 107–120.
- Hilson, G. (2000) Pollution prevention and cleaner production in the mining industry: an analysis of current issues. *Journal of Cleaner Production*, **8**: 119–126.
- Hoh, E., Hites, R.A. (2005) Brominated flame retardants in the atmosphere of the East–Central United States. *Environmental Science and Technology*, **39**(20): 7794–7802.
- Hu, D.F., Martinez, A., *et al.* (2008) Discovery of non-Aroclor PCB (3,3'-dichlorobiphenyl) in Chicago air. *Environmental Science and Technology*, **42**(21): 7873–7877.
- International Institute of Concern for Public Health (1998) Environmental influences on the health of children. In International Conference on *Children's Health and the Environment*, Amsterdam, July 1998.
- Jackson, L.E. (2003) The relationship of urban design to human health and condition. *Landscape and Urban Planning*, **64**(4): 191–200.
- Jacob, J.S., Lopez, R. (2009) Is denser greener? An evaluation of higher density development as an urban stormwater-quality best management practice. *Journal of the American Water Resources Association*, **45**(3): 687–701.
- Jamshidi, A., Hunter, S., *et al.* (2007) Concentrations and chiral signatures of polychlorinated biphenyls in outdoor and indoor air and soil in a major U.K. conurbation. *Environmental Science and Technology*, **41**(7): 2153–2158.
- Johnson, A., Olson, N. (2001) Analysis and occurrence of polybrominated diphenyl ethers in Washington State freshwater fish. *Archives of Environmental Contamination and Toxicology*, **41**(3): 339–344.
- Jones-Otazo, H.A., Clarke, J.P., *et al.* (2005) Is house dust the missing exposure pathway for PBDEs? An analysis of the urban fate and human exposure to PBDEs. *Environmental Science and Technology*, **39**(14): 5121–5130.

- Kajiwara, N., Noma, Y., *et al.* (2008) Photolysis studies of technical decabromodiphenyl ether (DecaBDE) and ethane (DeBDethane) in plastics under natural sunlight. *Environmental Science and Technology*, **42**(12): 4404–4409.
- Kemmlin, S., Hahn, O., *et al.* (2003) Emissions of organophosphate and brominated flame retardants from selected consumer products and building materials. *Atmospheric Environment*, **37**(39–40): 5485–5493.
- Kim, S.J., Kim, J.G., *et al.* (2009) Survey of PCDDs and PCDFs in air and soil around various incinerators in Korea, 2003–2007. *Bulletin of Environmental Contamination and Toxicology*, **83**(3): 435–439.
- Kohler, M., Tremp, J., *et al.* (2005) Joint sealants: an overlooked diffuse source of polychlorinated biphenyls in buildings. *Environmental Science and Technology*, **39**(7): 1967–1973.
- Kolic, T.M., Shen, L., *et al.* (2009) The analysis of halogenated flame retardants by GC-HRMS in environmental samples. *Journal of Chromatographic Science*, **47**(1): 83–91.
- Kolpin, D.W., Skopec, M., *et al.* (2004) Urban contribution of pharmaceuticals and other organic wastewater contaminants to streams during differing flow conditions. *Science of the Total Environment*, **328**(1–3): 119–130.
- Kwamena, N.O.A., Thornton, J.A., *et al.* (2004) Kinetics of surface-bound benzo[a]pyrene and ozone on solid organic and salt aerosols. *Journal of Physical Chemistry A*, **108**(52): 11626–11634.
- Kwamena, N.O.A., Clarke, J.P., *et al.* (2007) Assessing the importance of heterogeneous reactions of polycyclic aromatic hydrocarbons in the urban atmosphere using the multimedia urban model. *Atmospheric Environment*, **41**(1): 37–50.
- Labencki, T., Diamond, M.L., *et al.* (2009) Variability in and mechanisms of PAH washoff from urban impervious surfaces. *Chemosphere* (submitted).
- Lam, B., Diamond, M.L., *et al.* (2005) Chemical composition of surface films on glass windows and implications for atmospheric chemistry. *Atmospheric Environment*, **39**(35): 6578–6586.
- Lemieux, P.M., Stewart, E.S., *et al.* (2002) Pilot-scale studies on the effect of bromine addition on the emissions of chlorinated organic combustion by-products. *Waste Management*, **22**(4): 381–389.
- Leone, A.D., Ulrich, E.M., *et al.* (2000) Organochlorine pesticide concentrations and enantiomer fractions for chlordane in indoor air from the US cornbelt. *Atmospheric Environment*, **34**(24): 4131–4138.
- Li, Y., Zhang, Q., *et al.* (2009) Levels and vertical distributions of PCBs, PBDEs, and OCPs in the atmospheric boundary layer: observation from the Beijing 325-m Meteorological Tower. *Environmental Science and Technology*, **43**(4): 1030–1035.
- Liu, J.G., Daily, G.C., *et al.* (2003) Effects of household dynamics on resource consumption and biodiversity. *Nature*, **421**(6922): 530–533.
- Liu, Q.T., Chen, R., *et al.* (2003a) Characterization of polar organic compounds in the organic film on indoor and outdoor glass windows. *Environmental Science and Technology*, **37**(11): 2340–2349.
- Liu, Q.T., Diamond, M.L., *et al.* (2003b) Accumulation of metals, trace elements and semi-volatile organic compounds on exterior window surfaces in Baltimore. *Environmental Pollution*, **122**(1): 51–61.
- Loos, R., Gawlik, B.M., *et al.* (2009) EU-wide survey of polar organic persistent pollutants in European river waters. *Environmental Pollution*, **157**(2): 561–568.
- Lopes, T.J., Bender, D.A. (1998) Nonpoint sources of volatile organic compounds in urban areas – relative importance of land surfaces and air. *Environmental Pollution*, **101**(2): 221–230.
- Lopes, T. J., Dionne, S. G. (1998). A review of semivolatile and volatile organic compounds in highway runoff and urban stormwater, US GS.
- Lutes, C. C., Ryan, J. V. (1994) Characterization of air emissions from the simulated open combustion of fiberglass materials. Project Summary, US EPA, Research Triangle Park, North Carolina.
- Lyons, T.J., Kenworthy, J.R., *et al.* (1990) Urban structure and air pollution. *Atmospheric Environment Part B – Urban Atmosphere*, **24**(1): 43–48.
- McDonnell, M.J., Pickett, S.T.A., *et al.* (1997) Ecosystem processes along an urban-to-rural gradient. *Urban Ecosystems*, **1**: 21.
- Mahler, B.J., Van Metre, P.C., *et al.* (2005) Parking lot sealcoat: an unrecognized source of urban polycyclic aromatic hydrocarbons. *Environmental Science and Technology*, **39**(15): 5560–5566.

- Makepeace, D.K., Smith, D.W., *et al.* (1995) Urban stormwater quality – summary of contaminant data. *Critical Reviews in Environmental Science and Technology*, **25**(2): 93–139.
- Marsalek, J., Watt, W.E., *et al.* (1997) Physical and chemical characteristics of sediments from a stormwater detention pond. *Water Quality Journal of Canada*, **32**: 89.
- Matos, G., Wagner, L. (1998) Consumption of materials in the United States, 1900–1995. *Annual Review of Energy and the Environment*, **23**: 107–122.
- Matthiessen, P., Law, R.J. (2002) Contaminants and their effects on estuarine and coastal organisms in the United Kingdom in the late twentieth century. *Environmental Pollution*, **120**(3): 739–757.
- Mikaelian, I., de Lafontaine, Y., *et al.* (2000) Prevalence of lip neoplasms of white sucker (*Catostomus commersoni*) in the St. Lawrence River basin. *Canadian Journal of Fisheries and Aquatic Sciences*, **57**: 174–181.
- Moody, C.A., Martin, J.W., *et al.* (2002) Monitoring perfluorinated surfactants in biota and surface water samples following an accidental release of fire-fighting foam into Etobicoke Creek. *Environmental Science and Technology*, **36**(4): 545–551.
- Moreau-Guigon, E., Motelay-Massei, A., *et al.* (2007) Vertical and temporal distribution of persistent organic pollutants in Toronto. 1. Organochlorine pesticides. *Environmental Science and Technology*, **41**(7): 2172–2177.
- Motelay-Massei, A., Ollivon, D., *et al.* (2004) Distribution and spatial trends of PAHs and PCBs in soils in the Seine River basin, France. *Chemosphere*, **55**(4): 555–565.
- Motelay-Massei, A., Harner, T., *et al.* (2005) Using passive air samplers to assess urban–rural trends for persistent organic pollutants and polycyclic aromatic hydrocarbons. 2. Seasonal trends for PAHs, PCBs, and organochlorine pesticides. *Environmental Science and Technology*, **39**(15): 5763–5773.
- Mueller, J.A., Ditoro, D.M., *et al.* (1995) Fate of octamethylcyclotetrasiloxane (OMCTS) in the atmosphere and in sewage-treatment plants as an estimation of aquatic exposure. *Environmental Toxicology and Chemistry*, **14**(10): 1657–1666.
- Nelson, E.D., McConnell, L.L., *et al.* (1998) Diffusive exchange of gaseous polycyclic aromatic hydrocarbons and polychlorinated biphenyls across the air–water interface of the Chesapeake Bay. *Environmental Science and Technology*, **32**(7): 912–919.
- Newman, P.W.G. (1999) Sustainability and cities: extending the metabolism model. *Landscape and Urban Planning*, **44**(4): 219–226.
- Offenberg, J.H., Baker, J.E. (1997) Polychlorinated biphenyls in Chicago precipitation: enhanced wet deposition to near-shore Lake Michigan. *Environmental Science and Technology*, **31**(5): 1534–1538.
- Offenberg, J.H., Naumova, Y.Y., *et al.* (2004) Chlordanes in the indoor and outdoor air of three US cities. *Environmental Science and Technology*, **38**(10): 2760–2768.
- Offenberg, J., Simcik, M., *et al.* (2005) The impact of urban areas on the deposition of air toxics to adjacent surface waters: a mass budget of PCBs in Lake Michigan in 1994. *Aquatic Sciences*, **67**(1): 79–85.
- Overcash, M. (2002) The evolution of US pollution prevention, 1976–2001: a unique chemical engineering contribution to the environment – a review. *Journal of Chemical Technology and Biotechnology*, **77**(11): 1197–1205.
- Parker, W.J., Shi, J.C., *et al.* (1999) Pilot plant study to assess the fate of two volatile methyl siloxane compounds during municipal wastewater treatment. *Environmental Toxicology and Chemistry*, **18**(2): 172–181.
- Peck, A.M., Hornbuckle, K.C. (2004) Synthetic musk fragrances in Lake Michigan. *Environmental Science and Technology*, **38**(2): 367–372.
- Peck, A.M., Hornbuckle, K.C. (2006a) Environmental sources, occurrence, and effects of synthetic musk fragrances. *Journal of Environmental Monitoring*, **8**(9): 874–879.
- Peck, A.M., Hornbuckle, K.C. (2006b) Synthetic musk fragrances in urban and rural air of Iowa and the Great Lakes. *Atmospheric Environment*, **40**(32): 6101–6111.
- Perdue, W.C., Gostin, L.W., *et al.* (2003) Public health and the built environment: historical, empirical, and theoretical foundations for an expanded role. *Journal of Law and Medical Ethics*, **31**: 557.
- Perera, F.P., Rauh, V., *et al.* (2006) Effect of prenatal exposure to airborne polycyclic aromatic hydrocarbons on neurodevelopment in the first 3 years of life among inner-city children. *Environmental Health Perspectives*, **114**(8): 1287–1292.

- Petreas, M., Oros, D. (2009) Polybrominated diphenyl ethers in California wastestreams. *Chemosphere*, **74**(7): 996–1001.
- Phillips, P.J., Wall, G.R., *et al.* (2000) Pesticides in wells in agricultural and urban areas of the Hudson River Basin. *Northeastern Geographical and Environmental Science*, **22**: 1.
- Poschl, U., Letzel, T., *et al.* (2001) Interaction of ozone and water vapor with spark discharge soot aerosol particles coated with benzo[*a*]pyrene: O³ and H₂O adsorption, benzo[*a*]pyrene degradation, and atmospheric implications. *Journal of Physical Chemistry A*, **105**(16): 4029–4041.
- Pouyat, R.V., Parmelee, R.W., *et al.* (1994) Environmental effects of forest soil – invertebrate and fungal densities in oak stands along an urban–rural land-use gradient. *Pedobiologia*, **38**(5): 385–399.
- Prevedouros, K., Brorström-Lundén, E., *et al.* (2004) Seasonal and long-term trends in atmospheric PAH concentrations: evidence and implications. *Environmental Pollution*, **128**(1–2): 17–27.
- Priemer, D.A., Diamond, M.L. (2002) Application of the multimedia urban model to compare the fate of SOCs in an urban and forested watershed. *Environmental Science and Technology*, **36**(5): 1004–1013.
- Rayne, S., Ikonomidou, M.G., *et al.* (2005) Polychlorinated dioxins and furans from the World Trade Center attacks in exterior window films from lower Manhattan in New York City. *Environmental Science and Technology*, **39**(7): 1995–2003.
- Reiss, R., Mackay, N., *et al.* (2002) An ecological risk assessment for triclosan in lotic systems following discharge from wastewater treatment plants in the United States. *Environmental Toxicology and Chemistry*, **21**(11): 2483–2492.
- Ren, N., Sverko, E., *et al.* (2008) Levels and isomer profiles of dechlorane plus in Chinese air. *Environmental Science and Technology*, **42**(17): 6476–6480.
- Rimkus, G., Rimkus, B., *et al.* (1994) Nitro musks in human adipose tissue and breast milk. *Chemosphere*, **28**(2): 421–432.
- Robson, M., Harrad, S. (2004) Chiral PCB signatures in air and soil: implications for atmospheric source apportionment. *Environmental Science and Technology*, **38**(6): 1662–1666.
- Rock, M. T. (2002) Pollution control in East Asia: lessons from newly industrialising economies. Respite for the Future, Washington, DC.
- Roesner, L.A., Bledsoe, B.P., *et al.* (2001) Are best-management-practice criteria really environmentally friendly? *Journal of Water Resources Planning and Management – ASCE*, **127**(3): 150–154.
- Rogge, W.F., Hildemann, L.M., *et al.* (1993a) Sources of fine organic aerosol. 2. Noncatalyst and catalyst-equipped automobiles and heavy-duty diesel trucks. *Environmental Science and Technology*, **27**(4): 636–651.
- Rogge, W.F., Hildemann, L.M., *et al.* (1993b) Sources of fine organic aerosol. 3. Road dust, tire debris, and organometallic brake lining dust – roads as sources and sinks. *Environmental Science and Technology*, **27**(9): 1892–1904.
- Rudel, R.A., Perovich, L.J. (2009) Endocrine disrupting chemicals in indoor and outdoor air. *Atmospheric Environment*, **43**(1): 170–181.
- Rudel, R.A., Seryak, L.M., *et al.* (2008) PCB-containing wood floor finish is a likely source of elevated PCBs in residents' blood, household air and dust: a case study of exposure. *Environmental Health*, **7**.
- Sahely, H.R., Dudding, S., *et al.* (2003) Estimating the urban metabolism of Canadian cities: Greater Toronto Area case study. *Canadian Journal of Civil Engineering*, **30**(2): 468–483.
- Salthammer, T., Schwarz, A., *et al.* (1999) Emission of reactive compounds and secondary products from wood-based furniture coatings. *Atmospheric Environment*, **33**(1): 75–84.
- Salzman, J. (1999) Beyond the smokestack: environmental protection in the service economy. *UCLA Law Review*, **47**(2): 411–489.
- Schueler, T. (1994) The importance of imperviousness. *Watershed Protection Technology*, **1**: 100.
- Schueler, T., Kumble, P.A., *et al.* (1992) *A current assessment of best management practices, techniques for reducing nonpoint source pollution in the coastal zone*. Metropolitan Washington Council of Governments Washinto, DC.
- Seika, M., Metz, N., *et al.* (1996) Characteristics of urban and state emission inventories – a comparison of examples from Europe and the United States. *Science of the Total Environment*, **190**: 221–234.

- Sepulveda, M.S., Johnson, W.E., *et al.* (2002) An evaluation of biomarkers of reproductive function and potential contaminant effects in Florida largemouth bass (*Micropterus salmoides floridanus*) sampled from the St. Johns River. *Science of the Total Environment*, **289**(1–3): 133–144.
- Simcik, M.F., Zhang, H.X., *et al.* (1997) Urban contamination of the Chicago coastal Lake Michigan atmosphere by PCBs and PAHs during AEOLOS. *Environmental Science and Technology*, **31**(7): 2141–2147.
- Sorensen, A.A., Greene, R.P., *et al.* (1997) *Farming on the edge*. American Farmland Trust, Washington, DC.
- Stapleton, H.M., Allen, J.G., *et al.* (2008) Alternate and new brominated flame retardants detected in U.S. house dust. *Environmental Science and Technology*, **42**(18): 6910–6916.
- Stone, B., Rodgers, M.O. (2001) 'Urban form and thermal efficiency - How the design of cities influences the urban heat island effect.' *Journal of the American Planning Association*, **67**(2): 186–198.
- Strandberg, B., Dodder, N.G., *et al.* (2001) Concentrations and spatial variations of polybrominated diphenyl ethers and other organohalogen compounds in Great Lakes air. *Environmental Science and Technology*, **35**(6): 1078–1083.
- Struger, J., Boyter, D., *et al.* (1994) Environmental concentrations of urban pesticides. In Conference on *Current Practices in Modelling the Management of Stormwater Impacts*, Toronto, Canada, 24–25 February, pp. 85–98.
- Sztruhar, D., Sokac, M., *et al.* (1997) Conjunctive monitoring of a sewer system and receiving waters in a medium sized community. *Water Science and Technology*, **36**(8–9): 271–276.
- Takigami, H., Suzuki, G., *et al.* (2008) Transfer of brominated flame retardants from components into dust inside television cabinets. *Chemosphere*, **73**(2): 161–169.
- Takigami, H., Suzuki, G., *et al.* (2009) Brominated flame retardants and other polyhalogenated compounds in indoor air and dust from two houses in Japan. *Chemosphere*, **76**(2): 270–277.
- Tasdemir, Y., Vardar, N., *et al.* (2004) Concentrations and gas/particle partitioning of PCBs in Chicago. *Environmental Pollution*, **131**(1): 35–44.
- Templeton, S.R., Zilberman, D., *et al.* (1998) An economic perspective on outdoor residential pesticide use. *Environmental Science and Technology*, **32**(17): 416A–423A.
- Totten, L.A., Gigliotti, C.L., *et al.* (2004) Atmospheric concentrations and deposition of polychlorinated biphenyls to the Hudson River Estuary. *Environmental Science and Technology*, **38**(9): 2568–2573.
- Totten, L.A., Panangadan, M., *et al.* (2006) Direct and indirect atmospheric deposition of PCBs to the Delaware River watershed. *Environmental Science and Technology*, **40**(7): 2171–2176.
- Traynor, G.W., Apte, M.G., *et al.* (1990) Selected organic pollutant emissions from unvented kerosene space heaters. *Environmental Science and Technology*, **24**(8): 1265–1270.
- US EPA (1998) Locating and estimating air emissions from sources of polycyclic organic matter. Environmental Publications Agency, Cincinnati, Ohio.
- US EPA (2004) Our built and natural environments: technical review of the interactions between land use, transportation, and environmental quality. National Service Center for Environmental Publications Agency, Cincinnati, Ohio.
- VanBuren, M.A., Watt, W.E., *et al.* (1996) Enhancing the removal of pollutants by an on-stream pond. *Water Science and Technology*, **33**(4–5): 325–332.
- Van Gerven, T., Geysen, D., *et al.* (2004) Estimation of the contribution of a municipal waste incinerator to the overall emission and human intake of PCBs in Wilrijk, Flanders. *Chemosphere*, **54**(9): 1303–1308.
- Van Metre, P.C., Mahler, B.J. (2005) Trends in hydrophobic organic contaminants in urban and reference lake sediments across the United States, 1970–2001. *Environmental Science and Technology*, **39**(15): 5567–5574.
- Van Metre, P.C., Mahler, B.J., *et al.* (2000) Urban sprawl leaves its PAH signature. *Environmental Science and Technology*, **34**(19): 4064–4070.
- Van Metre, P.C., Mahler, B.J., *et al.* (2009) PAHs underfoot: contaminated dust from coal-tar sealcoated pavement is widespread in the United States. *Environmental Science and Technology*, **43**(1): 20–25.

- van Nuijs, A.L.N., Pecceu, B., *et al.* (2009) Cocaine and metabolites in waste and surface water across Belgium. *Environmental Pollution*, **157**(6): 1968–1969.
- Venier, M., Ferrario, J., *et al.* (2009) Polychlorinated dibenzo-*p*-dioxins and dibenzofurans in the atmosphere around the Great Lakes. *Environmental Science and Technology*, **43**(4): 1036–1041.
- Wagrowski, D.M., Hites, R.A. (1996) Polycyclic aromatic hydrocarbon accumulation in urban, suburban, and rural vegetation. *Environmental Science and Technology*, **31**(1): 279–282.
- Watkinson, A.J., Murby, E.J., *et al.* (2009) The occurrence of antibiotics in an urban watershed: from wastewater to drinking water. *Science of the Total Environment*, **407**(8): 2711–2723.
- Wolkoff, P. (1995) Volatile organic compounds – sources, measurements, emissions, and the impact on indoor air quality. *Indoor Air*, **5** 1–73.
- Wong, F., Harner, T., *et al.* (2004) Using experimental and forest soils to investigate the uptake of polycyclic aromatic hydrocarbons (PAHs) along an urban–rural gradient. *Environmental Pollution*, **129**(3): 387–398.
- Wong, F., Robson, M., *et al.* (2009) Concentrations and chiral signatures of POPs in soils and sediments: a comparative urban versus rural study in Canada and UK. *Chemosphere*, **74**(3): 404–411.
- Wright, P., Mason, C.F. (1999) Spatial and seasonal variation in heavy metals in the sediments and biota of two adjacent estuaries, the Orwell and the Stour, in eastern England. *Science of the Total Environment*, **226**(2–3): 139–156.
- Wu, R.W., Harner, T., *et al.* (2008) Evolution rates and PCB content of surface films that develop on impervious urban surfaces. *Atmospheric Environment*, **42**(24): 6131–6143.
- Yu, C., Crump, D. (1998) A review of the emission of VOCs from polymeric materials used in buildings. *Building and Environment*, **33**(6): 357–374.
- Zhang, H.X., Eisenreich, S.J., *et al.* (1999) Evidence for increased gaseous PCB fluxes to Lake Michigan from Chicago. *Environmental Science and Technology*, **33**(13): 2129–2137.
- Zhang, Z., Liu, L., *et al.* (2008) Analysis of polychlorinated biphenyls in concurrently sampled Chinese air and surface soil. *Environmental Science and Technology*, **42**(17): 6514–6518.

7

The Contamination of Indoor Environments with Persistent Organic Pollutants

Stuart Harrad

Division of Environmental Health and Risk Management, School of Geography, Earth, and Environmental Sciences, University of Birmingham, UK

7.1 Introduction

Until relatively recently, it was held widely that human exposure to POPs occurred predominantly via the diet. While this appears true for pollutants like dioxins, a burgeoning portfolio of research has challenged this paradigm for those POPs with significant indoor use patterns. For such pollutants, like brominated flame retardants (BFRs), polychlorinated biphenyls (PCBs), and perfluorinated chemicals (PFCs), it appears reasonable to hypothesise that their extensive deployment in indoor applications leads to contamination of indoor air and dust, with resultant implications for human exposure via inhalation and ingestion. Such potential exposures are compounded by the high proportion of time spent indoors – estimated at 22 hours per day for UK adults (ECETOC, 2001). Furthermore, while there still remains considerable uncertainty surrounding human dust ingestion rates, it is agreed widely that they are greater for young children (USEPA, 1997, 2002).

This chapter will first review critically methods for monitoring BFRs, PCBs, and PFCs in indoor air and dust. It will then summarise the concentrations in such matrices of these contaminants, together with the factors that influence such contamination and its implications for human exposure, and will make recommendations as to future research needs in this area.

7.2 Methods of Sampling

7.2.1 Indoor Air

Sampling indoor air for POPs has been conducted via three approaches: (a) high-volume active sampling (Currado and Harrad, 1998; Harrad *et al.*, 2004), (b) low-volume active sampling (Allen *et al.*, 2007; Mandalakis *et al.*, 2008), and (c) passive air sampling (Gevao *et al.*, 2006a; Harrad, Hazrati, and Ibarra, 2006; Mandalakis, Atsarou, and Stephanou, 2008; Wilford *et al.*, 2004). Each approach has benefits and disadvantages. These are summarised in Table 7.1.

7.2.2 Indoor Dust

There are also a number of approaches taken to sampling indoor dust. It is important to emphasise that the matrix under study is settled dust for which the exposure pathway is ingestion (usually accidental, but for a small number of individuals, particularly young

Table 7.1 *Relative attributes of active and passive sampling approaches to monitoring POPs in indoor air*

Sampling method	Advantage	Disadvantage
Active (high and low volume)	Air sampling rates well-defined, hence enhanced accuracy	Higher sampling rates ($\sim 0.2\text{--}1\text{ m}^3/\text{min}$) can mean volume of room exceeded, hence underestimation of concentrations (high volume only)
	Higher sampling rates result in lower detection limits (high volume only)	Noisy, obtrusive (less so for low volume), and require power supply, hence less versatile with respect to microenvironments in which they can be deployed (e.g. cars)
	Higher sampling rates facilitate study of short-term source-related concentration variations (high volume only)	Expensive (especially high volume)
Passive	Inexpensive	Air sampling rates less well-defined, hence less accurate
	Quiet, comparatively inobtrusive, and do not require power supply, hence can be deployed in nearly all microenvironments	Air sampling rates derived from a nontrivial calibration experiment
	Supply time weighted average concentrations that are suited ideally to monitoring chronic exposure	

children, deliberate). This is distinct from suspended dust, for which exposure will occur via inhalation. One approach to sampling dust is to take the contents of vacuum cleaners (Harrad, Hazrati, and Ibarra, 2006; Wilford *et al.*, 2005), donated by householders. Advantages of this method are that it provides an integrated measure of contamination and thus potential exposure from throughout the rooms in which it is deployed. It is also cost-effective, and as it does not require the householder to allow a researcher access to their home, makes donor compliance more easily achievable. A major disadvantage is that it does not take account of the influence on exposure of within-house between-room variations in contamination. If such variations are substantial, then a vacuum cleaner bag sample will not reflect exposure to building occupants accurately if there is substantial discrepancy between the proportion of time an occupant spends in the different rooms of the building and the proportion of time that the cleaner was deployed in those rooms. Other disadvantages of the vacuum cleaner bag sampling approach are that it is susceptible to problems with post-sampling contamination (vacuum cleaner components may well be treated with BFRs and/or PFCs), and/or loss due to volatilisation and/or degradation); that the vacuum cleaner may have been used outside the home; and that the differences in 'sampling rates' of different vacuum cleaners and the periods represented by each dust sample hamper true comparison across samples.

An alternative (Abdallah, Harrad, and Covaci, 2008; Abdallah *et al.*, 2008; Allen *et al.*, 2008b; Harrad, Abdallah, and Covaci, 2009; Harrad *et al.*, 2008b, 2008c; Stapleton *et al.*, 2005; Wu *et al.*, 2007) is to use members of the research team to procure samples using the same vacuum cleaner for all samples. Although this can result in difficulties with obtaining donor compliance it does facilitate comparability between samples obtained within a given study. Another advantage is that it minimises sample contamination/loss issues by the use of pre-extracted sample receptacles (e.g. soxhlet thimbles/'socks' – Harrad *et al.*, 2008c; Wu *et al.*, 2007) placed within the 'sampling train' (furniture attachment), which are replaced before taking each sample and are transported to the laboratory for storage under controlled conditions as soon as practicable. However, this approach still has potential problems in tackling the issue of the period represented by each sample. Specifically, there is no guarantee that donors will adhere to the research team's request that the room to be sampled should not be vacuumed for a set number of days prior to sampling.

Even among those using the approach of researcher-procured samples, there are potentially important variations in methodology. One is to sample the entire surface of a given room until sufficient mass of dust is collected (cited as 15–30 minutes by Stapleton *et al.*, 2005) while the other is to sample a standardised floor area for a standardised time period within each room (Abdallah, Harrad, and Covaci, 2008; Abdallah *et al.*, 2008; Harrad, Abdallah, and Covaci, 2009; Harrad *et al.*, 2008b, 2008c). As discussed later, there are within-room variations in dust contamination with BFRs (Harrad, Abdallah, and Covaci, 2009; Harrad *et al.*, 2008b). These mean that vacuuming the entire room may oversample less-frequented parts of a room; equally that sampling one specific area of a room may not give a complete assessment of contamination within the room. However, it may be argued that the latter approach may provide a more biologically relevant dust sample provided that the area sampled corresponds to the most-frequented part of the room.

At the current time, it is not clear as to whether using vacuum cleaner bags or researcher-collected samples is more suitable. Allen *et al.* (2008b) compared concentrations of PBDEs in vacuum cleaner dust with researcher-collected samples from 20 homes, finding only poor

to moderate correlation between the concentrations detected in the two sample types, with concentrations significantly lower in the vacuum cleaner dust. Although this confirms the influence of the sampling method deployed, without matching measurements of body burden for the occupants of the sampled homes, it does not indicate which approach provides a more biologically relevant assessment of exposure. Similarly, there are no data comparing contamination present in ‘whole-room’ as opposed to ‘specific-area’ dust samples. This, combined with the absence of body burden measurements, means that no definitive assessment of the relative biological relevance of the two methods can be made. In conclusion, there is no universally agreed standard method for sampling indoor dust. Given the respective pitfalls/advantages of each method deployed to date, and the uncertainty as to which provides the most biologically relevant sample, there is currently insufficient information available to allow the development of a standardised method of dust sampling. In summary, it appears more important that the sampling method deployed is ‘fit-for-purpose’ with respect to the specific aims of the study and that as much detail as possible should be provided when reporting study results.

Alternative approaches to evaluating the magnitude of indoor contamination with POPs have also been reported. Some studies have argued that lint from clothes dryers provides an effective passive monitor (Pless-Mulloli *et al.*, 2006; Stapleton *et al.*, 2005). While more detailed study is required, there are two potential problems with this approach, viz: (a) it may only be applied to those microenvironments in which clothes dryers are used and (b) human ingestion of such lint would appear minimal. Another approach that has been employed (with similar rationale to clothes dryer lint) is the sampling of dust from air conditioning unit fans or filter blades (Tan *et al.*, 2007a). Although this has the benefit of sampling the atmosphere throughout the room in which it is deployed, this is of likely minimal additional value over the monthly timescales over which more conventional passive air samplers are deployed, and may only be applied in air-conditioned environments, thus limiting severely the environments in which it may be deployed.

7.3 Sources and Levels of Indoor Contamination

7.3.1 General Observations

While these vary depending on compound class, for all POPs considered in this chapter, indoor–outdoor air concentration ratios exceed 1 (Abdallah, Harrad, and Covaci, 2008; Currado and Harrad, 1998; Harrad, Hazrati, and Ibarra, 2006; Shoeib *et al.*, 2004, 2005). Hence, unlike ‘classical’ air pollutants like particulate matter, nitrogen oxides, and ozone, there appears negligible influence of outdoor sources on the indoor environment.

In addition to the magnitude and number of potential sources, a number of factors can influence levels of indoor contamination. In the first instance, the relative ease with which different classes of POPs can undergo emission from products within which they are incorporated will influence indoor contamination. For example, while the production volume of TBBP-A far exceeds that of HBCD (BSEF, 2001), TBBP-A is present in far lower concentrations than HBCD in indoor air and dust (Abdallah *et al.*, 2008). Abdallah *et al.* (2008) attributed this observation to the fact that the principal use of TBBP-A is as a reactive flame retardant, whereas HBCD is used as an additive flame retardant. While

reactive flame retardants are bound covalently to the matrix (e.g. high impact polystyrene) within which they are deployed, additive flame retardants are simply mixed with the treated matrix; hence migration of additive flame retardants from treated products is markedly more facile.

Secondly, following emission, the relative partitioning between air and dust for a given compound will be influenced strongly by its physicochemical properties. Broadly, more volatile pollutants, like lower chlorinated PCBs, will partition preferentially to air, while those with lower vapour pressures, like BDE-209, HBCDs, and TBBP-A, will partition preferentially to dust (Abdallah, Harrad, and Covaci, 2008; Abdallah *et al.*, 2008; Harrad, Hazrati, and Ibarra, 2006; Harrad *et al.*, 2008b).

Additionally, it has been shown that photolytic isomerisation/degradation of HBCDs on indoor dust occurs in a fashion that both reduces the concentration of Σ HBCDs and effects a marked shift from γ - to α -HBCD (Harrad, Abdallah, and Covaci, 2009).

We will now address sources and levels of contamination of indoor air and dust for each compound class.

7.3.1.1 Polychlorinated Biphenyls

Although their manufacture and new use was prohibited in most Western countries in the late 1970s, there remains an essentially unquantified but likely substantial reservoir of these chemicals within contemporary indoor environments. The most likely ongoing applications for PCBs are their use in permanently elastic sealants used in building construction (e.g. window caulking – Kohler *et al.*, 2005; Herrick *et al.*, 2004) as dielectric fluids in capacitors and transformers, and in acoustic ceiling tiles (Heinzow *et al.*, 2004). Indeed, a survey of Swiss buildings constructed between 1950 and 1980 showed the importance of elastic joint sealants as a source of PCBs to indoor air (Kohler *et al.*, 2005). Figure 7.1 shows how, in the UK, PCB concentrations in indoor air are significantly higher in buildings constructed during the period of UK manufacture and new use (1954–1979) than in those constructed

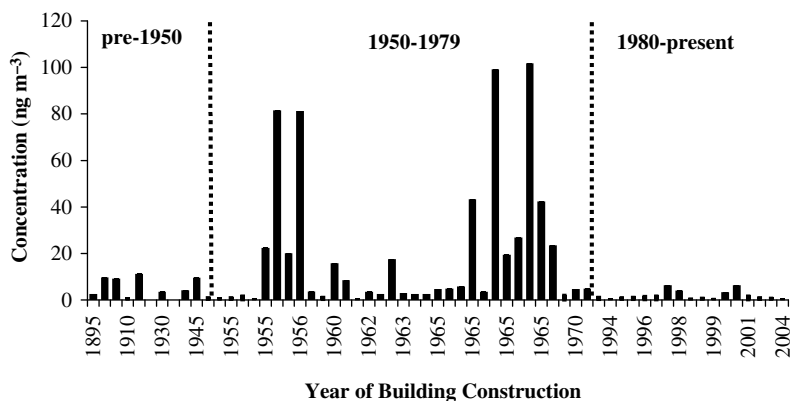

Figure 7.1 Variation of concentrations of Σ PCB in indoor air with date of building construction. (Reprinted with permission from *Environmental Science and Technology, Causes of Variability in Concentrations of Polychlorinated Biphenyls and Polybrominated Diphenyl Ethers in Indoor Air*, by Hazrati, S., Harrad, S., **40**(24), 7584–7589. Copyright (2006) American Chemical Society)

Table 7.2 Summary of concentrations (pg/m^3) of ΣPCBs in indoor and outdoor air samples from selected studies

Study location; number of samples (Reference)	Matrix	Minimum	Median	Average	Maximum
Birmingham, UK; $n = 92$ (Harrad, Hazrati, and Ibarra, 2006)	Indoor air	487	3538	10 725	101 762
Birmingham, UK; $n = 41$ (Currado and Harrad, 2000)	Outdoor air	76	–	290	1000
Switzerland; $n = 160$ (Kohler <i>et al.</i> , 2005)	Indoor Air	–	410 000	790 000	–
Massachusetts, USA; $n = 16$ (Vorhees, Cullen, and Altshul, 1997)	Indoor air	5200	–	10 000 (geometric mean)	51 000
Massachusetts, USA; $n = 20$ (Vorhees, Cullen, and Altshul, 1997)	Outdoor air	100	–	600 (geometric mean)	8200

post-1979 (Hazrati and Harrad, 2006). Table 7.2 summarises the ΣPCB concentrations detected in indoor air in a number of surveys worldwide, as well as those reported in outdoor air to illustrate the substantial indoor–outdoor concentration gradient.

As noted earlier, the comparatively high vapour pressures of some (lower chlorinated) PCBs implies that they will partition principally to indoor air, and this provides a plausible explanation as to why comparatively little attention has been paid to their contamination of indoor dust. However, a review of the available evidence suggests that dust may contain substantial concentrations of PCBs. Table 7.3 summarises reported concentrations of ΣPCBs in indoor dust (Harrad *et al.*, 2008a; Tan *et al.*, 2007b; Vorhees, Cullen, and Altshul, 1999). In addition, a few other studies have reported concentrations of a limited

Table 7.3 Summary of concentrations (ng/g) of ΣPCBs in indoor dust from selected studies

Study location; number of samples (Reference)	Minimum	Median	Average	Maximum
Toronto, Canada; $n = 10$ (Harrad <i>et al.</i> , 2008a)	56.3	260	290	819
Singapore; $n = 31$ (Tan <i>et al.</i> , 2007b)	< d.l.	5.6	9.2	44
Massachusetts, USA; $n = 15$ (Vorhees, Cullen, and Altshul, 1999)	260	710	–	3600
Birmingham, UK; $n = 20$ (Harrad <i>et al.</i> , 2008a)	5.7	48	110	860

d.l. = detection limit.

Table 7.4 Summary of principal applications of selected brominated flame retardants

BFR	Application
Penta-BDE	Printed circuit boards in electronics Polyurethane foam in carpet underlays, furniture upholstery, etc.
Octa-BDE	Acrylonitrile–butadiene–styrene (ABS) housing for electronic/electrical goods
Deca-BDE	High impact polystyrene (HIPS) housing for electronic/electrical goods Textiles
HBCD	Extruded and expanded polystyrene for thermal insulation of buildings Textiles
TBBP-A	Printed circuit boards ABS housing for electronic/electrical goods

number of individual PCB congeners in indoor dust (Colt *et al.*, 2005; Rudel, Seryak, and Brody, 2008; Rudel *et al.*, 2003; Wilson, Chuang, and Lyu, 2001).

7.3.1.2 Brominated Flame Retardants

Details on the production volumes of the major BFRs may be found in Chapter 2, but Table 7.4 summarises the principal uses of the same products.

Given the ubiquitous presence of many potential sources of PBDEs in indoor environments, many researchers have attempted to establish correlations between concentrations of PBDEs in indoor air and dust and the number of potential PBDE-containing items (e.g. electronics and PUF-containing furniture) in the same microenvironment. Such efforts have met with limited success (Gevao *et al.*, 2006a; Harrad *et al.*, 2004; Hazrati and Harrad, 2006). However, as discussed by Allen *et al.* (2007), this is likely to be attributable to misclassification of sources. This is because the PBDE content of goods will vary according to their age and manufacturing origin – e.g. temporal and spatial trends in PBDE use patterns alone will mean that a TV manufactured in one country in a given year may have a substantially different PBDE content to another manufactured elsewhere at a different point in time. As a consequence, Allen *et al.* (2008a) employed a portable X-ray fluorescence (XRF) detector to measure the bromine content of potential PBDE-containing items. They reported a markedly stronger correlation with PBDE concentrations in dust, when they regressed against the Br content of goods, than when using a simple count. However, the use of portable XRF detectors to identify better PBDE sources can still be confounded by misclassification arising from the presence in tested goods of BFRs other than PBDEs, such as HBCDs. Neither can it identify the type of PBDE present, which may be relevant in PCs where the penta-BDE formulation may have been used to flame-retard the printed circuit boards (Kemmlin, Bergman, and Jann, 2006), whereas deca-BDE was present in the high impact polystyrene (HIPS) housing (Weil and Levchik, 2007). Furthermore, as the XRF can only detect the presence of bromine close to the surface of the tested item, it may misclassify PBDE-containing items where the PBDE is contained within a product (e.g. in printed circuit boards inside computers).

Despite this problem of source misclassification, evidence exists of the role of specific source items in influencing contamination. With respect to indoor air, Figure 7.2 illustrates the findings of Hazrati and Harrad (2006), who reported an approximately 75% decrease in concentrations of Σtri-hexa-PBDEs (equal for all individual congeners monitored) in an office following the replacement of computers constructed in 1998, with one built in 2003 –

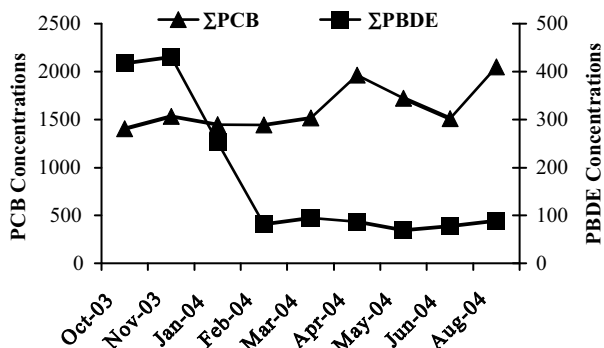

Figure 7.2 Temporal (month-to-month) variation in concentrations (pg/m^3) of ΣPCB and ΣPBDE in office. (Reprinted with permission from *Environmental Science and Technology, Causes of Variability in Concentrations of Polychlorinated Biphenyls and Polybrominated Diphenyl Ethers in Indoor Air*, by Hazrati, S., Harrad, S., **40**(24), 7584–7589. Copyright (2006) American Chemical Society)

the role of enhanced ventilation in this decrease was deemed minimal owing to the essentially constant levels of PCBs detected in the same samples. Furthermore, the observation elsewhere (Kemmlin, Bergman, and Jann, 2006; Kemmlin, Hahn, and Jann, 2003) that volatile emissions of PBDEs are enhanced due to unit heating during use is consistent with the fact that concentrations were reduced by only ~ 30 – 40% during an interim period where the office occupant used both the old and new computers. Similarly, a recent paper has reported a substantial attenuation in concentrations of HBCDs in dust with increasing distance from a TV set (Harrad, Abdallah, and Covaci, 2009). Likewise, extremely high concentrations of PBDEs (and TBBP-A) in dust taken from inside TV sets have been reported by Japanese researchers (Takigami *et al.*, 2008), and a marked increase in concentrations of BDE-209 in dust was noted to coincide with the introduction of a padded quilt cover and polyester fabric blinds (Harrad *et al.*, 2008b).

While the above provides evidence that BFR-containing goods are a source to the indoor environment, the mechanisms via which the BFRs migrate from goods to air/dust are not yet wholly understood. For the relatively volatile PBDEs present in the penta-BDE formulation, a number of studies have shown that their emissions occur as a result of volatilisation facilitated by above-ambient temperatures arising during use of treated goods like printed circuit boards within personal computers (Hazrati and Harrad, 2006; Kemmlin, Bergman, and Jann, 2006; Kemmlin, Hahn, and Jann, 2003). Similar release pathways would appear feasible for HBCD, given its similar volatility to BDE 99 (1.6×10^{-5} Pa for HBCD (Kemmlin, Hahn, and Jann, 2003) cf. 6.82×10^{-5} Pa for BDE 99 (Wong *et al.*, 2001)). In contrast, given its lower vapour pressure (4.63×10^{-6} Pa (Kemmlin, Hahn, and Jann, 2003)), volatilisation seems a less likely explanation for the extensive contamination of indoor dust with BDE-209 that has been reported in several regions (Allen *et al.*, 2008b; Gevao *et al.*, 2006b; Harrad *et al.*, 2008b, 2008c; Pless-Mullooli *et al.*, 2006; Schecter *et al.*, 2005; Sjödin *et al.*, 2006; Tan *et al.*, 2007a). Instead, recent research has been focusing on other processes: viz: direct transfer of BDE-209 into dust settled on the surface of treated goods; abrasion of fibres from flame-retarded textiles, or abrasion of particles from the surfaces of treated electronic goods. (Webster *et al.*, 2009).

Table 7.5 lists concentrations of BFRs reported in indoor air, along with typical concentrations in outdoor air for comparison. As for PCBs, the available data show that indoor concentrations exceed those detected outdoors by typically around an order of magnitude. Table 7.6 summarises current knowledge of the concentrations of BFRs in domestic indoor dust. For both indoor air and dust, it is of note that indoor concentrations of tri-hexa-BDEs are markedly higher in North America than elsewhere. This has been attributed widely to the far greater North American usage of the penta-BDE formulation. In contrast, concentrations of both HBCDs and BDE-209 in UK and US dust are not significantly different (suggesting that transatlantic differences in usage are less marked for these BFRs). Also noteworthy is that the substantial range of concentrations and discrepancy between median and average values demonstrate that the data are lognormally distributed. The exposure implications of these observations are explored later.

7.3.1.3 Perfluorinated Chemicals

Fuller details of the applications of PFCs may be found in Chapter 3. The database on indoor contamination with these chemicals is to date less comprehensive than for either PCBs or PBDEs, but summaries of concentrations of selected PFCs in both indoor (and outdoor) air and indoor dust are given as Tables 7.7 and 7.8.

7.4 Relative Significance of Indoor Exposure

The previous section demonstrates clearly that concentrations of the POPs under consideration in this chapter are markedly higher in indoor air and dust than those detected in the corresponding matrices (air and soil respectively) outdoors. It is therefore pertinent to evaluate the significance of human exposure that arises from such indoor contamination relative to dietary exposure.

Indoor exposures are a function of the following factors, viz:

- contaminant concentration in air or dust in a given microenvironment;
- proportion of time spent in a given microenvironment;
- inhalation rate (for air);
- ingestion rate (for dust).

Additionally, there is the crucial consideration of the extent to which such external exposure translates into internal exposure or body burden. To date, there is only one paper that makes a definitive link between indoor contamination (specifically of dust) and body burden for PBDEs (Wu *et al.*, 2007). While there are few data relating to such bioavailability issues for indoor air and dust, the situation is not appreciably less certain than for dietary exposure. An important recent study (Huwe *et al.*, 2008) has compared the bioavailability of PBDEs administered to rats in both indoor dust and in corn oil. While there was considerable congener-specific variation in uptake, there were no significant differences in uptake for a given congener regardless of whether it was administered in dust or corn oil.

Given this evidence of similar availability of PBDEs associated with dust and diet, Table 7.9 summarises data on how contamination of indoor dust (and air) contributes to UK estimates of external human exposure to BFRs relative to dietary exposures. It is apparent

Table 7.5 Summary of concentrations of brominated flame retardants (pg/m^3) in indoor and outdoor air from selected studies

Study location; matrix; number of samples (Reference)	Statistical parameter/ BFR	α -HBCD	β -HBCD	γ -HBCD	Σ HBCDs	TBBP-A	BDE-47	BDE-99	Σ tri-hexa- BDEs ^a	BDE-209
Birmingham, UK; indoor air; $n = 62$ (HBCDs), 14 (TBBP-A), 92 (tri-hexa-BDEs) (Abdallah, Harrad, and Covaci, 2008; Harrad, Hazrati, and Ibarra, 2006)	Minimum	13	4	39	67	4	1.9	<d.l.	3.8	–
	Median	38	20	112	172	17	15	13	47	–
	Average	65	31	170	266	18	49	37	110	–
	Maximum	430	288	707	1291	33	568	634	1416	–
Birmingham, UK; outdoor air; $n = 5$ (HBCDs and TBBP-A), 110 (tri-hexa-BDEs) (Abdallah, Harrad, and Covaci, 2008; Harrad and Hunter, 2006)	Minimum	2.3	0.9	31	34	0.7	0.29	0.08	0.49	–
	Median	2.9	1.0	33	37	0.7	5.0	1.5	8.7	–
	Average	3.0	1.1	33	37	0.8	6.1	1.9	10.4	–
	Maximum	3.7	1.2	35	40	0.9	17.4	5.6	29.9	–

Ottawa, Canada; indoor air (outdoor air in parentheses); <i>n</i> = 74 indoor, 7 outdoor (Wilford <i>et al.</i> , 2004). For BDE-209, Ontario, Canada; outdoor air; <i>n</i> = 35 (Gouin <i>et al.</i> , 2006)	Minimum	–	–	–	–	–	<d.l. (<d.l.)	<d.l. (<d.l.)	2.0 (<d.l.)	<d.l.
	Median	–	–	–	–	–	66 (0.88)	15 (1.4)	100 (2.6)	
	Average	–	–	–	–	–	160 (0.87)	42 (1.1)	260 (2.2)	19
	Maximum	–	–	–	–	–	1600 (1.9)	890 (1.9)	3600 (4.4)	105
Boston, USA; indoor air from main living area; <i>n</i> = 20 (Allen <i>et al.</i> , 2007)	Minimum	–	–	–	–	–	<62	<49	82	<48
	Geometric Mean	–	–	–	–	–	145	60	289	94
	Average	–	–	–	–	–	–	–	–	–
	Maximum	–	–	–	–	–	2371	553	3512	651
Kuwait; indoor air, homes (offices in parentheses); <i>n</i> = 46 homes, 24 offices (Gevao <i>et al.</i> , 2006a)	Minimum	–	–	–	–	–	–	–	–	–
	Median	–	–	–	–	–	3.6 (19)	2.4 (2.3)	8.2 (8.6)	–
	Average	–	–	–	–	–	9.1 (19)	4.4 (6.7)	15.2 (32.7)	–
	Maximum	–	–	–	–	–	101 (274)	36.2 (77.6)	136 (390)	–

Table 7.6 Summary of concentrations of brominated flame retardants (ng/g) in domestic indoor dust from selected studies

Study location; number of samples (Reference)	Statistical parameter/ BFR	α -HBCD	β -HBCD	γ -HBCD	Σ HBCDs	TBBP-A	BDE-47	BDE-99	Σ tri-hexa- BDEs	BDE-209
Birmingham, UK; $n = 33, 30,$ and 18 for HBCDs, tri-hexa-BDEs, and BDE-209 respectively (Abdallah, Harrad, and Covaci, 2008; Harrad <i>et al.</i> , 2008b)	Minimum	22	9	70	140	<d.l.	1.2	2.8	7.1	<d.l.
	Median	380	93	670	1300	62	10	20	46	8100
	Average	3200	1000	4200	8300	87	15	36	77	260 000
	Maximum	66 000	26 000	75 000	140 000	382	58	180	250	2 200 000
UK; $n = 10$ (Santillo <i>et al.</i> , 2003)	Minimum	–	–	–	940	<d.l.	10	18	–	3800
	Median	–	–	–	3250	<d.l.	24.8	44	–	7100
	Average	–	–	–	3160	116	223	287	–	9820
	Maximum	–	–	–	6900	340	1980	2100	–	19 900
Ottawa, Canada; $n = 68$ (Wilford <i>et al.</i> , 2005)	Minimum	–	–	–	–	–	21	19	64 ^a	74
	Median	–	–	–	–	–	300	430	900 ^a	630
	Average	–	–	–	–	–	1100	1800	4500 ^a	1100
	Maximum	–	–	–	–	–	33 000	60 000	170 000 ^a	10 000
Toronto, Canada; $n = 8, 10,$ and 7 for HBCDs, tri-hexa-BDEs, and BDE-209 respectively (Abdallah <i>et al.</i> , 2008; Harrad <i>et al.</i> , 2008c)	Minimum	25	6	34	64	–	47	80	160	290
	Median	300	72	230	640	–	140	330	620	560
	Average	340	70	260	670	–	300	510	1100	670
	Maximum	670	130	470	1300	–	720	1800	3600	1100

Amarillo/Austin, Texas, USA; <i>n</i> = 13, 20, and 17 for HBCDs, tri-hexa-BDEs, and BDE-209 respectively (Abdallah <i>et al.</i> , 2008; Harrad <i>et al.</i> , 2008c)	Minimum	17	6	79	110	–	49	79	310	920
	Median	80	28	300	390	–	364	612	1600	1300
	Average	260	56	490	810	–	1621	2295	3000	1600
	Maximum	1800	300	2000	4000	–	10540	13840	14 000	3300
Boston, Massachusetts, USA; <i>n</i> = 46 (Wu <i>et al.</i> , 2007)	Minimum	–	–	–	–	–	240	290	590	<d.l.
	Median	–	–	–	–	–	670	1010	1910	<d.l.
	Average	–	–	–	–	–	–	–	–	–
	Maximum	–	–	–	–	–	14610	14800	34 400	9600
Dallas, Texas, USA; <i>n</i> = 9 (Schechter <i>et al.</i> , 2005)	Minimum	–	–	–	–	–	49	79	–	536
	Median	–	–	–	–	–	364	612	–	665
	Average	–	–	–	–	–	1621	2295	–	8567
	Maximum	–	–	–	–	–	10540	13840	–	65 780
Kuwait; <i>n</i> = 17 (Gevao <i>et al.</i> , 2006b)	Minimum	–	–	–	–	–	0.11	0.04	–	0.8
	Median	–	–	–	–	–	2.7	3.4	–	82.9
	Average	–	–	–	–	–	6.6	6.0	–	129
	Maximum	–	–	–	–	–	65.2	35.8	–	338
Wellington, New Zealand; <i>n</i> = 20 (Harrad <i>et al.</i> , 2008c)	Minimum	–	–	–	–	–	3.3	6.4	13	–
	Median	–	–	–	–	–	13	47	96	–
	Average	–	–	–	–	–	20	87	160	–
	Maximum	–	–	–	–	–	150	380	680	–
Singapore; <i>n</i> = 31 (Tan <i>et al.</i> , 2007a)	Minimum	–	–	–	–	–	<d.l.	<d.l.	11 ^b	68
	Median	–	–	–	–	–	20	24	98 ^b	1000
	Average	–	–	–	–	–	110	340	660 ^b	2200
	Maximum	–	–	–	–	–	1500	6300	12 000 ^b	13 000

^aIncludes 183 and 190.

^bIncludes 183.

Table 7.7 Summary of concentrations of perfluorinated substances (pg/m³) in indoor and outdoor air from selected studies

Study location; matrix; number of samples (Reference)	Statistical parameter/ PFS	6:2 FTOH	8:2 FTOH	10:2 FTOH	MeFOSE	EtFOSE	MeFOSEA	EtFOSEA
Ottawa, Canada; indoor air; <i>n</i> = 59 (Shoeib <i>et al.</i> , 2005)	Minimum	–	–	–	366	227	12	5.9
	Geometric mean	–	–	–	1490	744	29	40
	Average	–	–	–	1970	1100	35	59
	Maximum	–	–	–	8190	7740	109	646
Ottawa, Canada; Outdoor Air; <i>n</i> = 7 (Shoeib <i>et al.</i> , 2005)	Minimum	–	–	–	76	80	<d.l.	<d.l.
	Geometric mean	–	–	–	82	88	<d.l.	<d.l.
	Average	–	–	–	83	88	<d.l.	<d.l.
	Maximum	–	–	–	99	106	<d.l.	<d.l.
(a) Tromso, Norway; indoor air; <i>n</i> = 4; (b) Manchester, UK; outdoor air (02-03/05); <i>n</i> = 2 (Barber <i>et al.</i> , 2007)	Geometric mean (indoor)	3000	3400	3600	6400	5800	6600	6600
	Average (outdoor)	190	240	65	48	17	7.6	10
Hamburg, Germany; outdoor air; <i>n</i> = 7 (Jahnke <i>et al.</i> , 2007)	Minimum	33	62	16	5.3	2.9	3.4	1.3
	Median	–	–	–	–	–	–	–
	Average	66	119	35	41	14.3	9.0	3.1
	Maximum	149	275	93	107	39	20	5.9

Table 7.8 Summary of concentrations of perfluorinated substances (ng/g) in indoor dust from selected studies

Study location; number of samples (Reference)	Statistical parameter/PFS	6:2 FTOH	8:2 FTOH	10:2 FTOH	MeFOSE	EtFOSE	MeFOSEA	EtFOSEA	PFOS	PFOA	PFHxS
Ottawa, Canada; <i>n</i> = 66 (Shoeib <i>et al.</i> , 2005)	Minimum	–	–	–	3.3	1.4	0.7	<d.l.	–	–	–
	Geometric mean	–	–	–	113	138	7.9	<d.l.	–	–	–
	Average	–	–	–	412	2200	14	<d.l.	–	–	–
	Maximum	–	–	–	8860	75 440	44	<d.l.	–	–	–
Ottawa, Canada; <i>n</i> = 67 (Kubwabo <i>et al.</i> , 2005)	Minimum	–	–	–	–	–	–	–	2.3	1.2	2.3
	Median	–	–	–	–	–	–	–	38	20	23
	Average	–	–	–	–	–	–	–	444	106	392
	Maximum	–	–	–	–	–	–	–	5065	1234	4305
Japan; <i>n</i> = 16 (Moriwaki, Takata, and Arakawa, 2003)	Minimum	–	–	–	–	–	–	–	11	69	–
	Median	–	–	–	–	–	–	–	22	160	–
	Average	–	–	–	–	–	–	–	176	354	–
	Maximum	–	–	–	–	–	–	–	2500	3700	–
Ohio and North Carolina, USA; <i>n</i> = 112 (Strynar and Lindstrom, 2008)	Minimum	<d.l.	<d.l.	<d.l.	–	–	–	–	<d.l.	<d.l.	<d.l.
	Median	24	33	31	–	–	–	–	201	142	46
	Average	75	167	96	–	–	–	–	761	296	874
	Maximum	804	1660	883	–	–	–	–	12100	1960	35 700
Birmingham, UK (school classrooms); <i>n</i> = 20 (Goosey, Abdallah, and Harrad, 2008)	Minimum	–	–	–	–	–	–	–	85	42	–
	Median	–	–	–	–	–	–	–	1200	220	–
	Average	–	–	–	–	–	–	–	1300	240	–
	Maximum	–	–	–	–	–	–	–	3700	640	–

Table 7.9 Summary of relative significance (%) of exposure of UK adults and toddlers to selected BFRs via dust ingestion, inhalation, and diet under various scenarios

		% contribution to overall exposure							
BFR		Mean dust intake scenario (assuming concentrations of ingested dust and air at different specified levels, but uniform dietary exposure)							
		Adult				Toddler (6–24 months)			
		5th %ile	Average	Median	95th %ile	5th %ile	Average	Median	95th %ile
Σtri-hexa-BDEs	Air	0.2	0.1	2.2	7.3	0.0	0.3	0.7	1.7
	Dust	0.3	2.2	4.3	18.1	1.3	4.8	14.0	45.8
	Diet	99.5	97.7	93.5	74.6	98.7	94.9	85.3	52.5
BDE-209	Air	–	–	–	–	–	–	–	–
	Dust	9.5	46.7	94.2	98.9	14.2	69.6	98.1	99.7
	Diet	90.5	53.3	5.8	1.1	85.8	30.4	1.9	0.3
ΣHBCDs	Air	0.5	0.9	0.9	1.2	0.2	0.2	0.2	0.1
	Dust	1.4	23.9	7.2	52.5	5.5	62.6	26.5	85.8
	Diet	98.1	75.2	91.9	46.3	94.3	37.2	73.2	14.1
TBBP-A	Air	5.9	6.4	6.8	6.3	0.0	2.0	2.6	1.1
	Dust	11.8	34.0	29.5	50.0	92.9	89.8	86.8	94.4
	Diet	82.4	59.6	63.6	43.8	7.1	8.2	10.5	4.4
		High dust intake scenario (assuming concentrations of ingested dust and air at different specified levels, but uniform dietary exposure)							
Σtri-hexa-BDEs	Air	0.2	0.8	2.0	5.8	0.0	0.3	0.5	0.7
	Dust	1.9	8.7	18.9	37.1	6.5	25.2	45.3	68.8
	Diet	98.9	95.7	87.4	59.0	95.0	83.5	60.0	22.1

BDE-209	Air	–	–	–	–	–	–	–	–
	Dust	21.1	68.6	97.6	99.6	39.0	90.0	99.5	100.0
	Diet	78.9	31.4	2.4	0.4	61.0	10.0	0.5	0.0
ΣHBCDs	Air	0.3	0.4	0.4	0.5	0.1	0.1	0.1	0.0
	Dust	1.7	28.0	8.8	57.9	10.0	74.6	33.4	91.5
	Diet	98.1	71.6	90.8	41.5	89.9	25.3	66.5	8.4
TBBP-A	Air	4.9	4.2	4.8	3.5	0.0	0.5	0.7	0.3
	Dust	26.8	56.3	50.0	71.7	92.9	97.3	96.5	98.6
	Diet	68.3	39.4	45.2	24.8	7.1	2.2	2.8	1.1

Data taken from:

For Σtri-hexa-BDEs, air, diet, and dust data taken from Harrad, Hazrati, and Ibarra, 2006, and Harrad *et al.*, 2004 and 2008b respectively.

For BDE-209, no indoor air data available for the UK; dust data taken from Harrad *et al.*, 2008b, and diet data taken from UKFSA, 2006a.

For HBCDs and TBBP-A, air and dust data taken from Abdallah, Harrad, and Covaci, 2008.

For HBCDs, diet data taken from FSA, 2006a.

For TBBP-A, diet data taken from de Winter-Sorkina *et al.*, 2003.

Mean dust ingestion rates assumed to be 20 mg/day (adults), 50 mg/day (toddlers).

High dust ingestion rates assumed to be 50 mg/day (adults), 200 mg/day (toddlers).

that indoor exposures (in particular the ingestion of dust) constitute an important pathway of exposure. Furthermore, for some individuals – usually young children – ingestion of dust can represent the principal exposure pathway. UK data are presented in Table 7.9 as it is for this country that the most complete data set exists at the present time – there is in particular a dearth of up-to-date dietary exposure data for North America. However, it should be noted that while indoor contamination with most BFRs is similar in North America and Europe, concentrations of tri-hexa-BDEs in indoor dust are significantly higher in North America (see Table 7.6). As a consequence, the significance for North Americans of dust ingestion as an exposure pathway to these congeners has been deemed even higher than shown in Table 7.9 for the UK (Jones-Otazo *et al.*, 2005; Lorber, 2008).

Despite the evidence that PBDEs in dust and diet are bioavailable to similar degrees, it is still important to evaluate the extent to which estimates of external exposure via indoor pathways translates into internal exposure. To that end, as described above, previous surveys of the concentrations of PBDEs in indoor air and dust are lognormally distributed (Harrad, Hazrati, and Ibarra, 2006; Wilford *et al.*, 2005). Such heterogeneity has been suggested as a possible explanation for reports that while most human tissue samples display relatively similar levels of PBDEs, some individuals display significantly higher contamination (Petreas *et al.*, 2003; Thomas *et al.*, 2006). The plausibility of such a causative link between exposure via ingestion of indoor dust and human body burdens is supported further by the recent report of a statistically significant correlation between PBDE concentrations in human milk and those in indoor dust from the homes of US donors (Wu *et al.*, 2007). Furthermore, a recent study examined, via an analysis of handwipes, the concentrations of PBDEs present on the hands of 33 US individuals (Stapleton *et al.*, 2008). The close resemblance between the congener pattern observed on the handwipes and in household dust suggests strongly that dust particles are the source of PBDEs on hands. Although the authors cautioned that the PBDE handwipe residues may also be due to direct contact with PBDE-treated goods like remote controls, their estimates of exposure that would arise from hand-to-mouth contact are consistent with estimates reported as arising from dust ingestion.

Table 7.10 summarises the relative contribution of indoor air inhalation and diet to UK human exposure to Σ PCBs. Clearly, inhalation has the potential to make a significant contribution to the exposure of the UK population. While there are relatively few data available on which one may base a reliable estimate of human exposure to PCBs via indoor dust ingestion, an indication of its likely significance may be derived from Harrad *et al.* (2008a) who estimated that a UK toddler ingesting 200 mg/day of dust contaminated at the 95th percentile concentration (a high end exposure scenario) would receive 54 ng Σ PCB/day. From Table 7.10, this reveals dust ingestion to contribute up to 15% of toddler exposure. While not of the same magnitude as for some BFRs, the significantly higher PCB concentrations in Canadian household dust reported by Harrad *et al.* (2008a) suggest that dust ingestion may be more important in North America. The possibility of substantial international variation in the contribution of dust ingestion to overall PCB exposure is supported by Tan *et al.* (2007b), who concluded that when compared to dietary exposure, ingestion of indoor dust made only a very low contribution to the exposure of the Singaporean population.

With respect to exposure to PFCs, there are as yet too few data to assess fully the relative contribution of indoor and dietary exposures. The most detailed evaluation to date was conducted for Canadian adults by Tittlemeir *et al.* (2007). Using their own dietary exposure

Table 7.10 Summary of relative significance (%) of exposure of UK adults and toddlers to Σ PCBs via inhalation and diet

% contribution to sum of inhalation and dietary exposure ^a	Adult				Toddler (6–24 months)			
	5th percentile	Median	Average	95th percentile	5th percentile	Median	Average	95th percentile
Air	4.2	15.0	30.6	63.3	1.4	5.4	12.6	36.4
Food	95.8	85.0	69.4	36.7	98.6	94.6	87.4	63.6

^aAssuming uniform dietary exposure (340 ng Σ PCB/day; Wearne *et al.*, 1996), but inhalation of air contaminated at different specified levels (Harrad, Hazrati, and Ibarra, 2006).

data alongside estimates for other exposure pathways derived from other studies; they estimated dust ingestion at 28 ng/day to contribute 6.8% of combined dietary, inhalation, and dust ingestion exposure to PFOS and PFOA. They deemed inhalation exposure minimal owing to the low vapour pressures of these PFCs. The estimate of exposure via dust ingestion generated by Strynar and Lindstrom (2008) for US adults was – at 46 ng/day – in broad agreement with that of Tittlemeir *et al.* (2007). However, no US dietary exposure estimate exists at present. The UK's Food Standards Agency has provided an estimate of UK dietary exposure to a range of PFCs including PFOS and PFOA (UKFSA, 2006b). This enabled Goosey, Abdallah, and Harrad (2008) to place in context their estimates of exposure via dust ingestion of children attending UK primary schools. Under a high exposure scenario (i.e. assuming children ingested 200 mg dust/day reduced pro rata to the time spent in the classroom, and that the dust was contaminated at the 95th percentile concentration) and comparing to high level, lower bound dietary exposures, dust ingestion contributed 17% and 27% of the sum of dust ingestion and dietary exposures to PFOS and PFOA respectively. Importantly, Goosey, Abdallah, and Harrad (2008) found that combined dust and dietary ingestion exposures were well below the UK government's provisional tolerable daily intakes for these contaminants. In summary, while it appears that indoor exposures to PFCs may not be as significant as for some BFRs, they are still appreciable, and it must be noted that the situation may not be the same for PFCs other than PFOS and PFOA.

7.5 Uncertainties in Estimates of Exposure via Dust Ingestion and Indoor Air Inhalation

While there is a substantial body of evidence that suggests dust ingestion and indoor air inhalation are significant pathways of exposure, it is important to note that there remains a degree of uncertainty regarding the absolute magnitude of the exposure estimates upon which such evidence is based. We discuss here the principal causes of such uncertainty.

7.5.1 Dust Ingestion Rates

There is considerable uncertainty surrounding dust ingestion rates, with those used derived from a very small number of studies using primary data collection (see

USEPA, 1997, 2002). This is underlined by the recent suggestion that the practice of basing estimates of human exposure on a 'default' dust ingestion rate, regardless of the dust loading of the room, may not always be appropriate. To illustrate, consider two identically dimensioned and ventilated rooms containing identical contaminant emission strengths but different dust loadings. In which will exposure be greater? One may hypothesise that there would be a lower mass-based concentration of contaminant due to dilution in the dustier room, but to what extent will the reduced exposure arising from the lower mass-based contaminant concentration be mitigated by a greater dust ingestion rate in such a microenvironment? As indicated above, there are currently no data addressing the influence of dust loading on dust ingestion rates, and research to fill this data gap would appear a priority. In contrast, recent preliminary data have examined the extent to which higher dust loadings 'dilute' concentrations of PBDEs and HBCDs in dust (Harrad, Abdallah, and Covaci, 2009; Harrad *et al.*, 2008b). A plot of dust loading versus BFR concentration should be linear with a negative slope, provided: (a) BFR emissions in the room remain essentially constant throughout the monitoring period and (b) the sources of the dust and of BFRs are independent. Figures 7.3(a) and (b) illustrate such a relationship for BDE-99 and Σ HBCDs in two rooms in which BFR concentrations in dust were measured once a month over a 9–10 month period. These figures suggest that the concept of 'dilution' may occur, but it should also be noted that no such relationship was apparent in the two other rooms studied.

7.5.2 Air Sampling Artefacts

To date there has been only one study that has deployed personal air samplers to monitor inhalation exposures (Allen *et al.*, 2007). This study compared airborne concentrations of a full suite of PBDEs measured using fixed point area samplers in a given individual's home with those measured using a personal exposure monitor fixed to the individual's lapel within 30 cm of the breathing zone while they were at home. Each home studied had an area sampler operational in both the bedroom and the main living area. The equipment used for both area and personal sampling was identical and fitted with both a particulate filter and a vapour phase sorbent. While concentrations of lower brominated congeners like 17 and 28 were not significantly different when measured by either personal or area monitors, those of more highly brominated congeners like 47, 99, 100, 153, 154, and 209 were significantly higher (by fourfold for BDE-209) when measured by the personal monitors. The authors attributed this to the fact that the personal monitor measurements for the higher molecular weight and thus more particulate phase-associated congeners were influenced by the 'personal cloud' effect, whereby human activities resuspend particulates and thus increase exposure to associated contaminants. As the vast majority of studies to date have not utilised personal exposure monitoring, it seems quite possible that such studies have underestimated exposure via inhalation.

7.5.3 Biological Relevance of Samples: Within-room/building Spatial and Temporal Variability of Contamination

As discussed earlier, it is also important to evaluate whether a single 'spot' measurement of contaminant concentration in air and/or dust from a given microenvironment represents a biologically relevant sample. Where not all of the surface area of a room is sampled to obtain

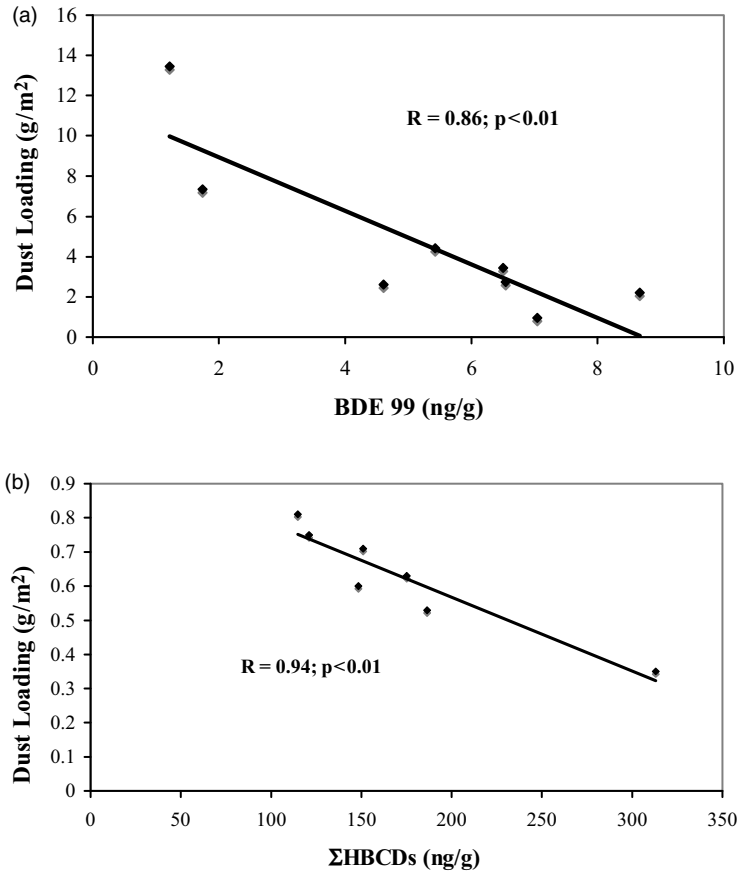

Figure 7.3 Relationship between dust loading and concentrations of: (a) BDE-99 and (b) Σ HBCDs in indoor dust. Negative linear correlation is indicative of 'dilution' of BFRs at higher dust loadings

a dust sample, one must consider the impact of within-room spatial variability. The extent of such variability in concentrations of both PBDEs and HBCDs in dust has been studied (Harrad, Abdallah, and Covaci, 2009; Harrad *et al.*, 2008b). The findings suggest that while in many rooms it will not influence exposure estimates significantly, in some microenvironments it exceeds substantially the measurement uncertainty. In contrast, while it has not been quantified for indoor air, it would seem unlikely to be significant, given atmospheric mixing.

In addition to within-room *spatial* variability, within-room *temporal* variability in both air and dust contamination has been the subject of several recent studies. For air, Hazrati and Harrad (2006) reported appreciable (but not always statistically significant) seasonal variation in concentrations of PCBs and tri-hexa-PBDEs in four homes and four offices. The seasonal variability was less pronounced than observed widely for PCBs in outdoor air (e.g. Currado and Harrad, 2000; Hillery *et al.*, 1997). This was attributed to: (a) the narrower temperature range indoors and (b) the mitigation of summer peaks in concentration due to

enhanced ventilation counteracting temperature-driven volatilisation during warmer months. Although this study appears the only data available for PBDEs, its findings regarding seasonal variation are consistent with earlier studies for PCBs. Specifically, concentrations of six PCB congeners in ten indoor environments in summer and winter were found to be significantly higher in summer, despite room temperatures being fairly constant throughout the year (Balfanz, Fuchs, and Kieper, 1993). Similarly, concentrations of dioxin like PCBs in five indoor environments in summer exceeded those in winter (Volland *et al.*, 2005), while two other studies have reported positive correlations between PCB concentrations in indoor air and the temperature of the room (Benthe *et al.*, 1992; Kohler *et al.*, 2005).

Changes in room contents may also influence strongly airborne contamination. Hence, studying within-room temporal variation offers insights both into the validity of basing exposure assessments on a single spot measurement of contamination, as well as source attribution. As shown in Figure 7.2, Hazrati and Harrad (2006) reported an approximately 75% decrease in concentrations of Σ tri-hexa-PBDEs (equal for all individual congeners monitored) in office air following the replacement of a computer constructed in 1998 with one built in 2003.

More recently, there have been three studies of within-room temporal variability in the contamination of dust with PBDEs (Allen *et al.*, 2008b; Harrad *et al.*, 2008b) and HBCDs (Harrad, Abdallah, and Covaci, 2009). The study of Allen *et al.* reported no significant change in concentrations of penta- and deca-BDE congeners in dust samples taken from the same rooms ($n = 40$) eight months apart. Conversely, the same authors reported a significant difference in concentrations of the octa-BDE congeners in the same sample set.

The temporal variability in concentrations of PBDEs in dust samples taken at monthly intervals in the same three home microenvironments over a 9–10 month period was monitored by Harrad *et al.* (2008b). The variability in the entire dataset of 9–10 monthly samples within each room expressed as the relative standard deviations (RSDs) of concentrations (ng Σ BDE/g) ranged between 58 and 166%, indicating at least moderate temporal variability. This was underlined further by the fact that in the three rooms studied, the maximum Σ tri-hexa-BDE concentration (ng/g) exceeded the minimum by a factor of ~ 50 , 3.5, and 5.5 in the three homes studied, while for BDE-209, the corresponding figures were 7.5, ~ 400 , and ~ 35 .

Harrad, Abdallah, and Covaci (2009) conducted a similar examination of the temporal variation in concentrations of HBCDs in dust from the same three rooms as those characterised for PBDEs by Harrad *et al.* (2008b). RSDs of concentrations of Σ HBCDs in these samples (27–190%) were broadly in line with those for PBDEs. Furthermore, the maximum concentration (ng Σ HBCDs/g) exceeded the minimum by a factor of 2.6, 224, and 4.0 in the studied rooms. Clearly, substantial variation in estimates of exposure is possible, depending when a given room is sampled. In both papers, the authors were able to attribute most of the temporal variability to changes in the contents of the rooms studied; for example, the temporary removal and reintroduction to one room of a TV shown elsewhere in the study to be a substantial source of HBCDs was demonstrated to coincide with significant changes in concentrations of HBCDs in dust.

The substantial temporal variations in the contamination of individual rooms reported by Harrad *et al.* (2008b) may – in combination with the observed short (15 day) human half-life of BDE-209 (Thuresson *et al.*, 2006) – provide an explanation for the marked (order of

magnitude) fall in contamination with BDE-209 of blood serum from members of one family sampled 90 days apart (Fischer *et al.*, 2006).

With respect to within-building variations in concentrations of POPs in dust, there appears to be only one study. In this, Allen *et al.* (2008b) reported that concentrations of penta- and deca-BDE congeners were on average significantly higher in the main living area compared to the bedroom in 20 homes. The same authors detected no significant difference in concentrations of octa-BDE congeners for the same sample set.

More data exists for indoor air, with within-building variations in concentrations of PCBs and PBDEs in air reported by Hazrati and Harrad (2006). In this study, sampling was conducted simultaneously in two separate rooms within the same three buildings (two homes and one office building) for 9–12 months. While concentrations of PBDEs and PCBs were not significantly different between the two rooms monitored in one home, this was considered to be due to the fact that the rooms (living room and bedroom) were contiguous and that the connecting door was usually kept open. In contrast, concentrations of all PBDEs and the most abundant PCB congeners were significantly higher in the bedroom as opposed to the living room in another home where the two rooms were on different floors. The authors could not attribute the concentration differences to differences in the number and nature of emission sources. Instead they suggested that the higher temperatures in the first floor room may have resulted in higher volatile emissions or that the lower concentrations in the ground floor room may have been attributable to higher ventilation rates.

In the office building (constructed in 1998), concentrations of all but two PCB congeners (i.e. PCB 17/18, and 32) in the two rooms studied were statistically indistinguishable. In contrast, the concentrations of all PBDE congeners monitored differed significantly between the two rooms. As overall building characteristics were similar for both rooms, variations in concentrations were considered due to differences in room usage pattern (e.g. computer usage and type/age/manufacture, and room ventilation rates) and the presence of different source types and numbers in the rooms. For instance, while one room contained seven PUF containing chairs and six PCs, the other housed one PC and four chairs.

The same study also monitored concurrently during one month four rooms located in different floors of another office building constructed in 1965 during the period of peak PCB usage in the UK. While concentrations of PBDEs showed only moderate variability between rooms (from 10 to 50 pg/m³), concentrations of Σ PCB in one room were – at 43 ng/m³ – about an order of magnitude higher than in the rest. While the authors could identify no obvious differences in potential sources of PCBs (or PBDEs) in the four rooms studied, principal component analysis revealed that while the vast majority of indoor air samples displayed a congener pattern that resembled closely that of the Aroclor 1016 and 1242 commercial formulations, the PCB congener pattern displayed in the outlier room was distinct and resembled most closely Aroclor 1248.

7.6 International Differences in Indoor Contamination

Of additional interest is the cause(s) of the observed order of magnitude higher concentrations of tri-hexa-BDEs (i.e. those present in the penta-BDE commercial formulation) in human tissues from North America compared to elsewhere (Hites, 2004). It has been suggested that these differences may be due to intercontinental variations in exposure via

ingestion of indoor dust (Harrad, Hazrati, and Ibarra, 2006; Schechter *et al.*, 2003). Estimates of dietary exposure in Canada, UK, and US are comparatively close at ca. 50–100 ng/day (D’Silva *et al.*, 2006; Harrad *et al.*, 2004; Huwe and Larsen, 2005; Jones-Otazo *et al.*, 2005; Schechter *et al.*, 2006). This, coupled with the recent report of Harrad *et al.* (2008c) that Canadian and US exposure to tri-hexa-BDEs via dust ingestion exceeds by an order of magnitude that in the UK and New Zealand, supports this hypothesis. In contrast, the story for BDE-209 may be different. Exposure to this congener via dust ingestion has been shown to be similar in North America and the UK (Harrad *et al.*, 2008c). However, there are insufficient data on both dietary exposure to BDE-209 and human body burdens to evaluate whether any international differences exist in such parameters, and further investigation of these issues appear warranted.

7.7 Concentrations in Different Microenvironment Categories

Given the likely variation in the deployment of goods containing POPs in different microenvironment categories – for example, one would anticipate a higher density of BFR-treated PCs, printers, etc., in office as opposed to domestic microenvironments – it might be expected that there would be appreciable differences in the concentrations of POPs in such categories. Tables 7.11 and 7.12 summarise the concentrations of target contaminants detected in air and dust from various microenvironment categories and demonstrate that substantial differences exist. The significantly greater airborne concentrations of PCBs in offices as opposed to homes suggests less extensive use of PCB-containing building sealants in domestic buildings. Likewise, the significantly higher concentrations of tri-hexa-BDEs detected in offices compared to homes is not unexpected, in view of the greater preponderance in offices of potential sources of these congeners. In contrast, there are no

Table 7.11 Summary of median concentrations (pg/m^3) of brominated flame retardants and PCBs in indoor air from different microenvironment categories in Birmingham, UK

Pollutant; number of samples (Reference)	Microenvironment category		
	Homes	Offices	Cars
Σ tri-hexa-BDEs; $n = 31, 33,$ and 25 for homes, offices, and cars respectively (Harrad, Abdallah, and Ibarra, 2006)	24	71	41
Σ HBCDs; $n = 33$ and 25 for homes and offices respectively (Abdallah, Harrad, and Covaci, 2008)	180	170	–
TBBP-A; $n = 5$ for both homes and offices (Abdallah, Harrad, and Covaci, 2008)	15	11	–
Σ PCBs; $n = 31, 33,$ and 25 for homes, offices, and cars respectively (Harrad, Abdallah, and Ibarra, 2006)	1800	5900	930

Table 7.12 Summary of median concentrations (ng/g) of brominated flame retardants and PFOS in dust from different microenvironment categories in selected studies

Pollutant; number of samples (Reference)	Microenvironment category			
	Homes	Offices	Day care centres/ primary school classrooms	Cars
Σ tri-hexa-BDEs; $n = 30$, 18, and 20 for homes, offices, and cars respectively (Harrad <i>et al.</i> , 2008b)	46	100	–	190
BDE-209; $n = 18$, 15, and 9 for homes, offices, and cars respectively (Harrad <i>et al.</i> , 2008b)	8100	6200	–	100 000
Σ HBCDs; $n = 45$, 28, 20, and 20 for homes, offices, primary school classrooms, and cars respectively (Abdallah, Harrad, and Covaci, 2008; Goosey, Abdallah, and Harrad, 2008)	1300	760	5200	13 000
TBBP-A; $n = 35$, 28, 20, and 20 for homes, offices, primary school classrooms, and cars respectively (Abdallah, Harrad, and Covaci, 2008; Goosey, Abdalla, and Harrad, 2008)	62	36	110	2
PFOS; $n = 10$, 38, 10, 10, and 5 for houses, apartments, offices, daycare centres, and cars respectively (Björklund, Thuresson, and de Wit, 2008)	39 (houses); 19 (apartments)	110	32	11

significant differences in concentrations of HBCDs and TBBP-A in offices and homes, and while the median PFOS concentration in office dust exceeded appreciably that in domestic dust, no indication of whether this difference was significant was given. Of potential significance is the observation that concentrations of HBCDs and TBBP-A in primary school classroom dust exceed significantly those in offices. While caution is needed given the relatively small number ($n = 20$) of classroom dust samples, further investigation of classroom contamination appears justified. Of particular interest are the levels of contamination detected in air and dust from cars. Concentrations of PBDEs and HBCDs are

significantly higher in vehicles than in other microenvironments. Conversely, cars appear comparatively uncontaminated with PCBs, PFOS, and TBBP-A. These observations probably reveal compound-specific differences in the extent of their use in vehicles.

Such differences in contamination raises questions as to the relative contributions of different microenvironments to overall exposure. To date, this has not been explored in any detail. However, a recent study that confirmed earlier findings of high PBDE concentrations in vehicles (Harrad, Hazrati, and Ibarra, 2006) estimated that 29% of inhalation exposure to PBDEs (including BDE-209) occurred as a result of time spent in cars (Mandalakis *et al.*, 2008).

Also of note is that, to date, estimates of indoor exposure are population-based, and as yet there exists a dearth of studies of the extent of personal exposure indoors. This may be important in identifying particularly exposed individuals, who may frequent a series of microenvironments containing elevated concentrations of POPs. To date, however, this has yet to be examined for exposures received via either air inhalation or dust ingestion – the study of Allen *et al.* (2007) monitored personal inhalation exposures in the home only.

7.8 Influence of Indoor Contamination on Outdoor Contamination

Given the likely vast reservoir of POPs associated with indoor environments (in air, dust, and in treated goods/materials), Harrad and Diamond (2006) proposed that this reservoir was exerting and would continue to exert, for the foreseeable future, a significant impact on outdoor contamination and thus human exposure. This concept is dealt with in detail in Chapter 8, but is mentioned here briefly to underline further the importance of indoor contamination. In short, several studies have shown marked ‘urban pulses’ of both PCBs and PBDEs, whereby concentrations in both outdoor air and soil are correlated positively with the distance from the urban centres of Birmingham, UK, and Toronto, Canada (Harner *et al.*, 2006; Harrad and Hunter, 2006; Jamshidi *et al.*, 2007; Motelay-Massei *et al.*, 2005). A further link between indoor and outdoor contamination was made by the correspondence between the chiral signatures of PCBs 95 and 149 in indoor and outdoor air, but not soil, in Birmingham (Jamshidi *et al.*, 2007).

7.9 Future Research Priorities

This chapter has shown the importance of indoor contamination with POPs and demonstrated clearly that it is a fertile area of research. While good progress has been made with furthering our knowledge of many aspects, there are a number of areas that the author believes will form the focus of research efforts over the next few years. Specifically, these include studies to:

1. Elucidate dust ingestion rates better, including how they vary with the dust loading in a microenvironment.
2. Characterise, in more depth, the extent and causes of within-room spatial and temporal variability in dust contamination.
3. Characterise better the extent and causes of within-building spatial variability.

4. Determine the bioavailability to humans of pollutants other than PBDEs in dust.
5. Quantify personal exposures of individuals via air inhalation and dust ingestion.
6. Elucidate the pathways via which less volatile chemicals like BDE-209 migrate from treated products into air and dust.
7. Characterise better the emission rates of POPs from treated goods.
8. Provide further understanding of the fate and partitioning of POPs in indoor environments.
9. Evaluate the extent to which indoor contamination impacts on the outdoor environment.

References

- Abdallah, M. A., Harrad, S., Covaci, A. (2008) Hexabromocyclododecanes and tetrabromobisphenol-A in indoor air and dust in Birmingham, UK: implications for human exposure. *Environ. Sci. Technol.*, **42**: 6855–6861.
- Abdallah, M., Harrad, S., Ibarra, C., Diamond, M., Melymuk, L., Robson, M., Covaci, A. (2008) Hexabromocyclododecanes in indoor dust from Canada, United Kingdom and United States. *Environ. Sci. Technol.*, **42**: 459–464.
- Allen, J. G., McClean, M. D., Stapleton, H. M., Nelson, J. W., Webster, T. F. (2007) Personal exposure to polybrominated diphenyl ethers (PBDEs) in residential indoor air. *Environ. Sci. Technol.*, **41**: 4574–4579.
- Allen, J. G., McClean, M. D., Stapleton, H. M., Webster, T. F. (2008a) Linking PBDEs in house dust to consumer products using X-ray fluorescence. *Environ. Sci. Technol.*, **42**: 4222–4228.
- Allen, J. G., McClean, M. D., Stapleton, H. M., Webster, T. F. (2008b) Critical factors in assessing exposure to PBDEs via house dust. *Environ. Int.*, **34**: 1085–1091.
- Balfanz, E., Fuchs, J., Kieper, H. (1993) Sampling and analysis of polychlorinated biphenyls (PCB) in indoor air due to permanently elastic sealants. *Chemosphere*, **26**: 871–880.
- Barber, J., Berger, U., Chaemfa, C., Huber, S., Jahnke, A., Temme, C., Jones, K. C. (2007) Analysis of per- and polyfluorinated alkyl substances in air samples from Northwest Europe. *J. Environ. Monit.*, **9**: 530–541.
- Benthe, C., Heinzow, B., Jessen, H., Rotard, S. M. W. (1992) Polychlorinated biphenyls – indoor air contamination due to thiokol rubber sealants in an office building. *Chemosphere*, **25**: 1481–1486.
- Björklund, J., Thuresson, K., de Wit, C. A. (2008) PFOS and PFOA from Stockholm Microenvironments. *Organohalogen Cpd.*, **70**: 863–866.
- BSEF (Bromine Science Environmental Forum) (2001) <http://www.bsef.com> (accessed January 2004).
- Colt, J. S., Severson, R. K., Lubin, J., Rothman, N., Camann, D., Davis, S., Cerhan, J. R., Cozen, W., Hartge, P. (2005) Organochlorines in carpet dust and non-Hodgkin lymphoma. *Epidemiology*, **16**: 516–525.
- Currado, G. M., Harrad, S. (1998) A comparison of polychlorinated biphenyl concentrations in indoor and outdoor air and the potential significance of inhalation as a human exposure pathway. *Environ. Sci. Technol.*, **32**: 3043–3047.
- Currado, G. M., Harrad, S. (2000) Factors influencing atmospheric concentrations of polychlorinated biphenyls in Birmingham, U.K. *Environ. Sci. Technol.*, **34**: 78–82.
- de Winter-Sorkina, R., Bakker, M., Van Donkersgoed, G., Van Klaveren, J. (2003) Dietary intake of brominated flame retardants by the Dutch population RIVM Report 310305001/2003
- D’Silva, K., Fernandes, A., White, S., Rose, M., Mortimer, D. N., Gem, M. (2006) Brominated organic micro-pollutants in the United Kingdom diet – results of the 2003 total diet study. *Organohalogen Cpd.*, **68**: 770–773.
- ECETOC (European Centre for Ecotoxicology and Toxicology of Chemicals) (2001) Exposure factors sourcebook for European populations (with focus on UK data). Technical Report 79, ISSN-0773-8072-79, Brussels.

- Fischer, D., Hooper, K., Athanasiadou, M., Athanassiadis, I., Bergman, Å. (2006) Children show highest levels of polybrominated diphenyl ethers in a California family of four: a case study. *Environ. Health Perspect.*, **114**: 1581–1584.
- Gevao, B., Al-Bahloul, M., Al-Ghadban, A. N., Ali, L., Al-Omair, A., Helaleh, M., Al-Matrouk, K., Zafar, J. (2006a) Polybrominated diphenyl ethers in indoor air in Kuwait: implications for human exposure. *Atmos. Environ.*, **40**: 1419–1426.
- Gevao, B., Al-Bahloul, M., Al-Ghadban, A. N., Al-Omair, A., Ali, L., Zafar, J., Helaleh, M. (2006b) House dust as a source of human exposure to polybrominated diphenyl ethers in Kuwait. *Chemosphere*, **64**: 603–608.
- Goosey, E., Abdallah, M. A., Harrad, S. (2008) Dust from primary school and nursery classrooms in the UK: its significance as a pathway of exposure of young children to PFOS, PFOA, HBCDs, and TBBP-A. *Organohalogen Cpd.*, **70**: 855–858.
- Gouin, T., Thomas, G. O., Chaemfa, C., Harner, T., Mackay, D., Jones, K. C. (2006) Concentrations of decabromodiphenyl ether in air from Southern Ontario: implications for particle-bound transport. *Chemosphere*, **64**: 256–261.
- Harner, T., Shoeib, M., Diamond, M., Ikononou, M., Stern, G. (2006) Passive sampler derived air concentrations of PBDEs along an urban–rural transect: spatial and temporal trends. *Chemosphere*, **64**: 262–267.
- Harrad, S., Abdallah, M. A., Covaci, A. (2009) Causes of variability in concentrations and diastereomer patterns of hexabromocyclododecanes in indoor dust. *Environ Int.*, **35**: 573–579.
- Harrad, S., Diamond, M. (2006) Exposure to polybrominated diphenyl ethers (PBDEs) and polychlorinated biphenyls (PCBs): current and future scenarios. *Atmos. Environ.*, **40**: 1187–1188.
- Harrad, S., Hazrati, S., Ibarra, C. (2006) Concentrations of polybrominated diphenyl ethers in indoor air and dust and polychlorinated biphenyls in indoor air in Birmingham. United Kingdom: implications for human exposure. *Environ. Sci. Technol.*, **40**: 4633–4638.
- Harrad, S., Hunter, S. (2006) Concentrations of Polybrominated Diphenyl Ethers in Air and Soil on a Rural-Urban Transect Across a Major UK Conurbation. *Environ. Sci. Technol.*, **40**: 4548–4553.
- Harrad, S., Wijesekera, R., Hunter, S., Halliwell, C., Baker, R. (2004) A preliminary assessment of UK human dietary and inhalation exposure to polybrominated diphenyl ethers. *Environ. Sci. Technol.*, **38**: 2345–2350.
- Harrad, S., Diamond, M., Melymuk, L., Robson, M., Ibarra, C. (2008a) Household dust ingestion as a pathway of human exposure to PCBs in Canada and the UK. Abstract of presentation at the 5th PCB Workshop, Iowa City, Iowa, May 18–22, http://tools.niehs.nih.gov/sbrp/1/Events/pcb_2008/pcb_abstracts.pdf (accessed June 2008).
- Harrad, S., Ibarra, C., Abdallah, M. A., Boon, R., Neels, H., Covaci, A. (2008b) Concentrations of brominated flame retardants in dust from United Kingdom cars, homes, and offices: causes of variability and implications for human exposure. *Environ. Int.*, **34**: 1170–1175.
- Harrad, S., Ibarra, C., Diamond, M., Melymuk, L., Robson, M., Douwes, J., Roosens, L., Dirtu, A. C., Covaci, A. (2008c) Polybrominated diphenyl ethers in domestic indoor dust from Canada, New Zealand, United Kingdom, and United States. *Environ. Int.*, **34**: 232–238.
- Hazrati, S., Harrad, S. (2006) Causes of variability in concentrations of polychlorinated biphenyls and polybrominated diphenyl ethers in indoor air. *Environ. Sci. Technol.*, **40**: 7584–7589.
- Heinzow, B. G. J., Mohr, S., Ostendorp, G., Kerst, M., Körner, W. (2004) Dioxin-like PCB in indoor air contaminated with different sources. *Organohalogen Cpd.*, **66**: 2470–2475.
- Herrick, R. F., McClean, M. D., Meeker, J. D., Baxter, L. K., Weymouth, G. A. (2004) An unrecognized source of PCB contamination in schools and other buildings. *Environ. Health Perspect.*, **112**: 1051–1053.
- Hillery, B. R., Basu, I., Sweet, C. W., Hites, R. A. (1997) Temporal and spatial trends in a long-term study of gas-phase PCB concentrations near the Great Lakes. *Environ. Sci. Technol.*, **31**: 1811–1816.
- Hites, R. A. (2004) Polybrominated diphenyl ethers in the environment and in people: a meta-analysis of concentrations. *Environ. Sci. Technol.*, **38**: 945–956.

- Huwe, J. K., Larsen, G. L. (2005) Polychlorinated dioxins, furans, biphenyls, and polybrominated diphenyl ethers in a U.S. meat market basket and estimates of dietary intake. *Environ. Sci. Technol.*, **39**: 5606–5611.
- Huwe, J. K., Hakk, H., Smith, D. J., Diliberto, J. J., Richardson, V., Stapleton, H. M., Birnbaum, L. S. (2008) Comparative absorption and bioaccumulation of polybrominated diphenyl ethers following ingestion via dust and oil in male rats. *Environ. Sci. Technol.*, **42**: 2694–2700.
- Jahnke, A., Ahrens, L., Ebinghaus, R., Temme, C. (2007) Urban versus remote air concentrations of fluoretolomer alcohols and other polyfluorinated alky substances in Germany. *Environ. Sci. Technol.*, **41**: 745–752.
- Jamshidi, A., Hunter, S., Hazrati, S., Harrad, S. (2007) Concentrations and chiral signatures of polychlorinated biphenyls in indoor and outdoor air and soil in a major UK conurbation. *Environ. Sci. Technol.*, **41**: 2153–2158.
- Jones-Otazo, H. A., Clarke, J. P., Diamond, M. L., Archbold, J. A., Ferguson, G., Harner, T., Richardson, G. M., Ryan, J. J., Wilford, B. (2005) Is house dust the missing exposure pathway for PBDEs? An analysis of the urban fate and human exposure to PBDEs. *Environ. Sci. Technol.*, **39**: 5121–5130.
- Kemmlin, S., Bergman, M., Jann, O. (2006) Emission test chamber study: specific emission rates of PBDE from selected materials under various conditions. *Organohalogen Cpd.*, **68**: 488–491.
- Kemmlin, S., Hahn, O., Jann, O. (2003) Emissions of organophosphate and brominated flame retardants from selected consumer products and building materials. *Atmos. Environ.*, **37**: 5485–5493.
- Kohler, M., Tremp, J., Zennegg, M., Seiler, C., Minder-Kohler, S., Beck, M., Lienemann, P., Wegmann, L., Schmid, P. (2005) Joint sealants: an overlooked diffuse source of polychlorinated biphenyls in buildings. *Environ. Sci. Technol.*, **39**: 1967–1973.
- Kubwabo, C., Stewart, B., Zhu, J., Maro, L. (2005) Occurrence of perfluorosulfonates and other perfluorochemicals in the city of Ottawa. *Canada. J. Environ. Monit.*, **7**: 1074–1078.
- Lorber, M. (2008) Exposure of Americans to polybrominated diphenyl ethers. *J. Exp. Sci. Environ. Epidemiol.*, **1**: 2–19.
- Mandalakis, M., Atsarou, V., Stephanou, E. G. (2008) Airborne PBDEs in specialized occupational settings, houses and outdoor areas in Greece. *Environ. Pollut.*, **155**: 375–382.
- Mandalakis, M., Stephanou, E. G., Horii, Y., Kannan, K. (2008) Emerging contaminants in car interiors: evaluating the impact of airborne PBDEs and PBDD/Fs. *Environ. Sci. Technol.*, **42**: 6431–6436.
- Moriwaki, H., Takata, Y., Arakawa, R. (2003) Concentrations of perfluorooctane sulfonate (PFOS) and perfluorooctanoic acid (PFOA) in vacuum cleaner dust collected in Japanese homes. *J. Environ. Monit.*, **5**: 753–757.
- Motelay-Massei, A., Harner, T., Shoeib, M., Diamond, M., Stern, G., Rosenberg, B. (2005) Using passive air samplers to assess urban–rural trends for persistent organic pollutants and polycyclic aromatic hydrocarbons. 2. Seasonal trends for PAHs, PCBs and organochlorine pesticides. *Environ. Sci. Technol.*, **39**: 5763–5773.
- Petreas, M., She, J., Brown, F. R., Winkler, J., Windham, G., Rogers, E., Zhao, G., Bhatia, R., Charles, M. J. (2003) High body burdens of 2,2',4,4'-tetrabromodiphenyl ether (BDE-47) in California women. *Environ. Health Perspect.*, **111**: 1175–1179.
- Pless-Mulloli, T., Schecter, A., Schilling, B., Paepke, O. (2006) Levels of PBDE in household dust and lint in the UK, Germany, and the USA. *Organohalogen Cpd.*, **66**: 495–498.
- Rudel, R. A., Seryak, L. M., Brody, J. G. (2008) PCB-containing wood floor finish is a likely source of elevated PCBs in residents' blood, household air and dust: a case study of exposure. *Environ. Health*, **7**(2); doi: 10.1186/1476-069X-7-2.
- Rudel, R. A., Camann, D. E., Spengler, J. D., Korn, L. R., Brody, J. G. (2003) Phthalates, alkylphenols, pesticides, polybrominated diphenyl ethers, and other endocrine-disrupting compounds in indoor air and dust. *Environ. Sci. Technol.*, **37**: 4543–4553.
- Santillo, D., Labunska, I., Davidson, H., Johnston, P., Strutt, M., Knowles, O. (2003) Consuming chemicals: hazardous chemicals in house dust as an indicator of chemical exposure in the home: Part I – UK. Greenpeace Research Laboratories Technical Note 01/2003, April 2003.

- Schechter, A., Pavuk, M., Pöpke, O., Ryan, J. J., Birnbaum, L., Rosen, R. (2003) Polybrominated diphenyl ethers (PBDEs) in U.S. mothers' milk. *Environ. Health Perspect.*, **111**: 1723–1729.
- Schechter, A., Pöpke, O., Joseph, J. E., Tung, K. -C. (2005) Polybrominated diphenyl ethers (PBDEs) in U.S. computers and domestic carpet vacuuming: possible sources of human exposure. *J. Toxicol. Environ. Health A.*, **68**: 501–513.
- Schechter, A., Pöpke, O., Harris, T. R., Tung, K. C., Musumba, A., Olson, J., Birnbaum, L. (2006) Polybrominated diphenyl ether (PBDE) levels in an expanded market basket survey of U.S. food and estimated PBDE dietary intake by age and sex. *Environ. Health Perspect.*, **114**: 1515–1520.
- Shoeb, M., Harner, T., Ikononou, M., Kannan, K. (2004) Indoor and outdoor air concentrations and phase partitioning of perfluoroalkyl sulfonamides and polybrominated diphenyl ethers. *Environ. Sci. Technol.*, **38**: 1313–1320.
- Shoeb, M., Harner, T., Wilford, B. H., Jones, K. C., Zhu, J. (2005) Perfluorinated sulfonamides in indoor and outdoor air and indoor dust: occurrence, partitioning, and human exposure. *Environ. Sci. Technol.*, **39**: 6599–6606.
- Sjödin, A., Pöpke, O., Focant, J. -F., Jones, R. S., Pless-Mulloli, T., Leontjew Toms, L.-M., Herrmann, T., Mueller, J., Needham, L. L., Patterson, D. G. Jr. (2006) Concentration of polybrominated diphenyl ethers (PBDEs) in household dust from various countries – is dust a major source of human exposure? *Organohalogen Cpd.*, **68**: 2181–2185.
- Stapleton, H. M., Dodder, N. G., Offenber, J. H., Schantz, M. M., Wise, S. A. (2005) Polybrominated diphenyl ethers in house dust and clothes dryer lint. *Environ. Sci. Technol.*, **39**: 925–931.
- Stapleton, H. M., Kelly, S. M., Allen, J. G., McClean, M. D., Webster, T. F. (2008) Measurement of polybrominated diphenyl ethers on hand wipes: estimating exposure from hand-to-mouth contact. *Environ. Sci. Technol.*, **42**: 3329–3324.
- Strynar, M. J., Lindstrom, A. B. (2008) Perfluorinated compounds in house dust from Ohio and North Carolina. *USA Environ. Sci. Technol.*, **42**: 3751–3756.
- Takigami, H., Suzuki, G., Hirai, Y., Sakai, S. (2008) Transfer of brominated flame retardants components into dust inside television cabinets. *Chemosphere*, **73**: 161–169.
- Tan, J., Cheng, S. M., Loganath, A., Chong, Y. S., Obbard, J. P. (2007a) Polybrominated diphenyl ethers in house dust in Singapore. *Chemosphere*, **66**: 985–992.
- Tan, J., Cheng, S. M., Loganath, A., Chong, Y. S., Obbard, J. P. (2007b) Selected organochlorine pesticide and polychlorinated biphenyl residues in house dust in Singapore. *Chemosphere*, **68**: 1675–1682.
- Thomas, G. O., Wilkinson, M., Hodson, S., Jones, K. (2006) Organohalogen chemicals in human blood from the United Kingdom. *Environ. Pollut.*, **141**: 30–41.
- Thureson, K., Hoglund, P., Hagmar, L., Sjödin, A., Bergman, Å., Jakobsson, K. (2006) Apparent half-lives of hepta- to decabrominated diphenyl ethers in human serum as determined in occupationally exposed workers. *Environ. Health Perspect.*, **114**: 176–181.
- Tittlemeir, S. A., Pepper, K., Seymour, C., Moisey, J., Bronson, R., Cao, X. -L., Dabeka, R. W. (2007) Dietary exposure of Canadians to perfluorinated carboxylates and perfluorooctane sulfonate via consumption of meat, fish, fast foods, and food items prepared in their packaging. *J. Agric. Food Chem.*, **55**: 3203–3210.
- UKFSA (United Kingdom Food Standards Agency) (2006a) Brominated chemicals: UK dietary intakes, Food Survey Information Sheet 10/06.
- UKFSA (United Kingdom Food Standards Agency) (2006b) Fluorinated chemicals: UK dietary intakes, Food Survey Information Sheet 11/06.
- USEPA (1997) *Exposure Factors Handbook*, Vol. 1 – *General Factors*. US Government Printing Office, EPA/600/P-95/002. Washington, DC.
- USEPA (2002) *Child-Specific Exposure Factors Handbook*. National Center for Environmental Assessment, EPA-600-P-00-002B, Washington, DC.
- Volland, G., Krause, G., Hansen, D., Zöltzer, D. (2005) Organic pollutants in indoor air – basics and problems. *Otto-Graf-Journal.*, **16**: 95–110.
- Vorhees, D. J., Cullen, A. C., Altshul, L. M. (1997) Exposure to polychlorinated biphenyls in residential indoor air and outdoor air near a superfund site. *Environ. Sci. Technol.*, **31**: 3612–3618.

- Vorhees, D. J., Cullen, A. C., Altshul, L. M. (1999) Polychlorinated biphenyls in house dust and yard soil near a superfund site. *Environ. Sci. Technol.*, **33**: 2151–2156.
- Wearne, S., Harrison, N., Gem, M., Startin, J., Wright, C., Kelly, M., Robinson, C., White, S., Hardy, D., Edinburgh, V. (1996) Time trend in human dietary exposure to PCDDs, PCDFs and PCBs in the UK. *Organohalogen Cpd.*, **30**: 1–6.
- Webster, T. F., Harrad, S., Millette, J. R., Holbrook, R. D., Davis, J. M., Stapleton, H. M., Allen, J. G., McClean, M. D., Ibarra, C., Abdallah, M. A., Covaci, A. (2009) Identifying transfer mechanisms and sources of decaBDE in indoor environments using forensic microscopy. *Environ. Sci. Technol.*, **43**: 3067–3072.
- Weil, E. D., Levchik, S. V. (2007) Flame retardants for polystyrenes in commercial use or development. *J. Fire Sci.*, **25**: 241–265.
- Wilford, B. H., Harner, T., Zhu, J., Shoeib, M., Jones, K. C. (2004) A passive sampling survey of polybrominated diphenyl ether flame retardants in indoor and outdoor air in Ottawa, Canada. *Environ. Sci. Technol.*, **38**: 5312–5318.
- Wilford, B. H., Shoeib, M., Harner, T., Zhu, J., Jones, K. C. (2005) Polybrominated diphenyl ethers in indoor dust in Ottawa, Canada: implications for sources and exposure. *Environ. Sci. Technol.*, **39**: 7027–7035.
- Wilson, N. K., Chuang, J. C., Lyu, C. (2001) Levels of persistent organic pollutants in several child day care centers. *J. Expos. Anal. Environ. Epidemiol.*, **11**: 449–458.
- Wong, A., Lei, Y. D., Mehran Alaei, M., Wania, F. (2001) Vapor pressures of the polybrominated diphenyl ethers. *J. Chem. Eng. Data*, **46**: 239–242.
- Wu, N., Herrmann, T., Paepke, O., Tickner, J., Hale, R., Harvey, E., La Guardia, M., McClean, M. D., Webster, T. F. (2007) Human exposure to PBDEs: associations of PBDE body burdens with food consumption and house dust concentrations. *Environ. Sci. Technol.*, **41**: 1584–1589.

8

The Chemicals That Will Not Go Away: Implications for Human Exposure to Reservoirs of POPs

Miriam Diamond¹ and Stuart Harrad²

¹Department of Geography, University of Toronto, Toronto, Ontario, Canada

*²Division of Environmental Health and Risk Management, School of Geography,
Earth, and Environmental Sciences, University of Birmingham, UK*

8.1 Introduction

POPs continue to fascinate and at times disturb (horrify) researchers, policy-makers and the public. As earlier chapters of this book describe, POPs are found globally in every natural and disturbed ecosystem. Our understanding of the ability of POPs to cause a wide range of subtle adverse health effects at relatively low concentrations continues to grow. We continue to revise our estimates of their persistence upwards as monitoring shows their very slow degradation rates under a range of environmental conditions.

In response to the continuing discovery of the persistence, bioaccumulative properties, and toxicity of POPs, regional, national and international policies ban the intentional production of compounds, such as polychlorinated biphenyls (PCBs), several organochlorine pesticides, such as mirex and dieldrin, and the brominated flame retardants polybrominated diphenyl ethers (penta-BDE and octa-BDE, and most recently, deca-BDE). Policies and programs have also targeted the unintentional production and release of POPs such as polychlorinated dibenzodioxins and furans (PCDD/Fs). Evidence of the success of these policies has been seen in immediate reductions of air concentrations, followed by declining concentrations in water bodies, soils, biota and our food supplies

(e.g. Jeremiason *et al.*, 1998; Meijer *et al.*, 2003a; Gauthier *et al.*, 2008; Law *et al.*, 2006; Szlinder-Richert *et al.*, 2009). However, the levels of some of these banned compounds are hovering around levels that could still be problematic (Bhavsar *et al.*, 2007; Fernie *et al.*, 2008; Verboven *et al.*, 2009). Several explanations have been proposed for the stubbornly elevated levels of some of the banned compounds, including their unanticipated persistence and slow release from large, uncontrollable reservoirs such as soils and sediments, and the ability of POPs released into the environment to cycle and recycle within and among environmental compartments (Bidleman *et al.*, 2006; Meijer *et al.*, 2003; Ockenden *et al.*, 2003). For some banned compounds, there is a growing recognition that primary emissions from existing stocks or releases, rather than secondary cycling, are responsible for maintaining elevated levels (Meijer *et al.*, 2003a; Robson and Harrad, 2004; Jamshidi *et al.*, 2007). We have argued previously that a reliance solely on bans on the manufacture and 'new' use of POPs without addressing significant existing *controllable* reservoirs will ultimately be ineffective in eliminating such chemicals from the environment (Harrad and Diamond, 2006). This chapter addresses the complex relationships that exist between the reservoirs of POPs, their migration from these reservoirs and the implications for human exposure, both present and future.

8.2 Conceptual Model of POPs

To begin this discussion we recall that POPs were originally synthesized and enjoyed widespread use because of their beneficial properties. Their high persistence meant that they could extend the life of materials into which they were added, such as PCBs in building sealants or electrical wiring, or perfluorooctane sulfonate, which allowed stains to be repelled from fabrics. The low flammability of PCBs reduced the danger of fires in electrical transformers and capacitors in which they were used in dielectric fluids. Their very low volatility minimized, but did not entirely prevent, their escape from materials such as the release of certain brominated flame retardants from plastics. Due to their persistence and ability for global transport, this slow rate of escape has translated into increasing concentrations in the receiving environment, which is the entire world!

The highly useful properties of nonpesticidal and intentionally produced POPs has resulted in their widespread usage in innumerable materials and products at low ppm to percentage concentrations. However, the mass of materials and products into which they have been added has grown and continues to grow at rates well above the growth of populations making use of them. As such, we have enormous reservoirs or stocks of materials and products that contain a much smaller, but toxicologically significant, mass of POPs.

We have come to recognize that the extremely low rate of escape of POPs from the reservoir, which is nested within the reservoir or stock of materials and products, is a source of concern because it could result in exposures that could cause subtle toxicological effects in humans and biota (Boucher *et al.*, 2009; Ashwood *et al.*, 2009; Fernie *et al.*, 2008, 2009).

Let us consider a conceptual model of the reservoirs, or stocks, and flows of a POP that leads to ecosystem and human exposure, as illustrated in Figure 8.1. We assume that the chemical is used in consumer products and building materials. Further, we assume that the greatest geographic concentration of the materials and products is in cities due to high urban population densities (Chapter 6). Over time, an increasing mass of materials

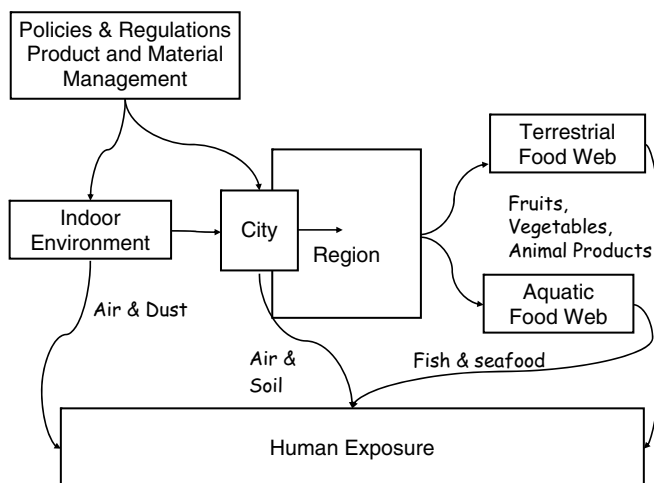

Figure 8.1 Conceptual model of sources, pathways and exposure to POPs with significant use in the built environment, from exposure via the indoor environment, cities and food, and finally the relationship with policy and regulation

containing the chemical will accumulate in the fabric of buildings, in goods and products inside the buildings, and/or in the built infrastructure. For the POP contained in building materials and consumer products, the low vapour pressure of the POP will result in a slow, but significant, release into the indoor environment or directly outdoors. The release can come from direct volatilization or ‘off-gassing’ as well as microscale abrasion of plastics (Kemmlin *et al.*, 2003; Webster *et al.*, 2009).

Following release, the POP compound will experience fate in the indoor environment according to its physical–chemical properties and characteristics of the indoor environment (Zhang *et al.*, 2009). Inevitably, indoor air concentrations will rise as the chemical seeks to establish equilibrium among all compartments of the indoor environment (Weschler and Nazaroff, 2008). In other words, the same principles of chemical fate that govern a chemical’s movement outdoors will govern its movement indoors. However, a crucial difference that leads to higher concentrations indoors than outdoors is the greatly reduced opportunities for removal and dilution by air and water advection indoors, especially as many homes and offices take steps to reduce heating (or cooling) losses by limiting air exchange rates (Weschler, 2009). Further, mechanisms leading to permanent chemical loss, such as photodegradation, biodegradation and burial to inaccessible soil or sediment layers, are usually much reduced or absent compared to outdoors (Weschler and Nazaroff, 2008).

As indoor air concentrations rise over time, people in those environments will be exposed to the chemical through air and/or dust inhalation and ingestion. The dominant mode of exposure will be a function of the chemical’s volatility or K_{oa} .

A fraction of the compound in indoor air and dust will inevitably be transported outdoors via building ventilation and dust removal, respectively. The fraction of total emissions to indoors that is released outdoors by way of ventilation and/or dust removal can be predicted by the chemical’s K_{oa} , the air exchange rate of the room or building, the dust removal rate and chemical dynamics within the room (Zhang *et al.*, 2009). Chemicals with lower values of K_{oa} ,

and thus mostly in air, will be exported via ventilation whereas chemicals with higher K_{oa} for which a significant fraction is in dust, will be exported via dust removal. The total fraction exported from indoors is a function of the air exchange rate, room temperature, activity and hence number of occupants within a room, age and function of the room, and the room's contents (Zhang *et al.*, 2009). Export fractions via ventilation can vary widely from nearly 100 to 20% of total releases to air for lower chlorinated PCB and higher brominated PBDE congeners, respectively (Zhang *et al.*, in prep). The removed dust may be deposited outdoors in landfill or incinerated, depending on the geographic location and personal practices.

In addition to 'leakage' from the indoor environment via ventilation, POPs enter the outdoor environment via liquid and solid discharges from waste water treatment plants. The liquid effluent is commonly discharged near population centres and biosolids can be intentionally applied to agricultural lands near those centres. Products containing POPs and the residue of our indoor environment (dust and rubbish) are deposited in landfills in many localities, some is dumped directly into the oceans, while others are incinerated. Given their persistence and volatility, POPs entering surface waters and oceans, applied to agricultural land and contained in landfills will all be potential emission sources to the surrounding environment.

Upon reaching the outdoor environment, POPs experience fate processes that are consistent with their physical–chemical properties and that of the receiving environment. Most compounds released to the city from indoor ventilation are exported via air advection; only a small proportion (typically 1–20%) is either retained in a city's soils or moves from impervious surfaces into surface waters (Diamond *et al.*, 2001; Jones-Otazo *et al.*, 2005). Unlike a typical forested environment, cities are poor sinks for chemicals (Priemer and Diamond, 2002; Diamond and Hodge, 2007) (see Chapter 7).

Although the POPs are diluted while moving downwind or downstream of a city, their persistence and bioaccumulative capacity means that following release to outdoors, POPs are effectively 'reconcentrated' by incorporation into the food chain, with concomitant impacts on our dietary exposure. In other words, some proportion of what we do not inhale in indoor air or ingest via indoor air or household dust now, we will ingest later via our diet. The 'we' includes populations near and far from the locations of the production, use and disposal of the materials and products since the stages in a product's life cycle often occur globally.

The extent to which a POP is reconcentrated in terrestrial and aquatic food webs is a function of its persistence, physical–chemical properties and properties of the receiving system. According to Kelley *et al.* (2007), persistent compounds with values of $\log K_{ow}$ between ~ 4 – 8 , 5 – 7 and 6 – 8 and $\log K_{oa}$ above ~ 8 that do not metabolize will biomagnify up to 400, 8000 and 4000 times in terrestrial mammalian, marine mammalian and human food chains, respectively. Compounds with values of $\log K_{ow}$ from 6 to 8 will biomagnify up to 75 times in aquatic food webs. The process of environmental transport and incorporation into food supplies will be accelerated if the compound is within biosolids applied to agricultural lands, in wastewater effluents discharged to surface waters and in dust deposited to landfills adjacent to agricultural lands, and if industrial facilities that use the compound are located nearby our sources of food.

In Figure 8.2 we visualize conceptually the time course of the relative importance of exposure routes – indoor air/dust versus diet – as a function of time. The absence of scale acknowledges the uncertainties involved and differences due to characteristics of the chemical and receiving environment.

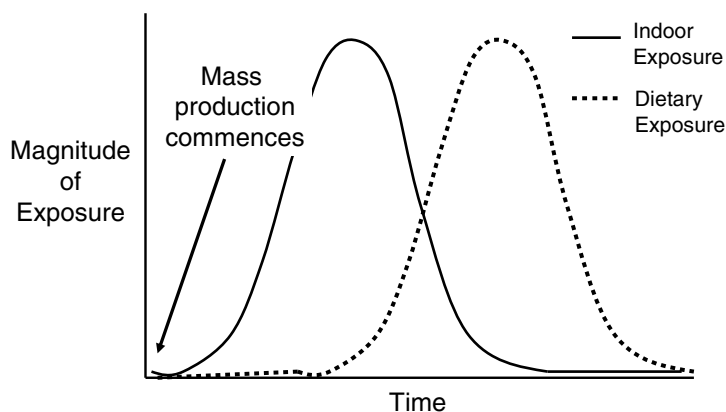

Figure 8.2 Hypothetical time course in the relative magnitude of human exposure to PCBs and PBDEs due to indoor exposure and dietary exposure. Note that the exact and relative magnitude of exposures and time frame of trends are illustrative. (Reproduced with permission)

Some time after production begins and our inventory or stock of materials and products containing the POP mounts, we will start to be exposed to the chemical via indoor air and/or dust. At this point, exposure will be predominantly through the indoor environment, which has the highest concentrations among all exposure media. Over time, as the chemical is released outdoors and is transferred within ecosystems, a growing mass of the chemical will accumulate in our food supply. At some point, our exposure to the chemical via food may supersede our indoor exposure due to the ability of the chemical to bioaccumulate and/or biomagnify. If the chemical is banned, then the inventory of materials and products containing the chemical will slowly be replaced and consequently the mass indoors and hence indoor exposure will decline. This will take time – a considerable time after a ban is introduced on *new production*. As the indoor reservoir declines, chemical releases from materials and products will continue to move from indoors to outdoors and into our food supply.

The magnitude of future exposures and the relative significance of exposure pathways depends on several factors, such as: (a) the production volume and uses of the chemical, (b) the mass of chemical in materials and consumer products yet to be released indoors and from indoors into the outdoor environment and (c) the efficiency with, and rate at, which these chemicals are incorporated into human foodstuffs. Further, the time frame of releases from building materials and consumer products to indoors and then outdoors depends on the replacement rate of the building materials (many decades) and consumer products (years). For example, lifetimes of large appliances are ~15 years, those of TVs and radios 5–15 years, but those of computers and mobile phones only 1–4 years (Delgado *et al.*, 2007). Thus, understanding the source–pathway–receptor relationships and the time course between chemical releases and human exposure is complex, owing to the interplay between: (a) emissions of POPs from their sources in materials and products over product life cycles (i.e. from cradle-to-grave), (b) the lag time between release and exposure (which can be lengthy in the case of the dietary pathway) and (c) the roles played by the characteristics of POPs and the receiving environment.

The importance of the issue of chemical repositories gains greater currency when noting that the rate of production and use of materials and goods, and, as such, their content of chemicals of potential concern, has been rising much faster than rates of population growth in the developed world. To illustrate this growth, Matos and Wagner (1998) calculated that per capita use of total materials increased five times, from 2 to 10 tonnes per year, in the US during the 20th century. Construction materials accounted for the greatest mass of materials used. However, plastics showed the greatest growth rate among materials, of over 25% since 1995 (Delgado *et al.*, 2007). Note that the annual rate of population growth in Western Europe and North America has been $\sim 0.4\%$ and worldwide is $\sim 1\%$ (<http://www.census.gov/ipc/www/idb/worldpopinfo.html>, accessed 31 May 2009). By comparison, the production of electrical and electronic goods in Western Europe has increased annually at 4.3%, to reach 6.7 million tonnes in 2000. The OECD has estimated a $\sim 6\%$ growth in synthetic chemical production annually, which is twice the rate of population growth of 3% in OECD countries (OECD, 2001).

The issue of rising stocks of materials and goods is most pronounced in cities. Brunner and Rechberger (2001) commented that cities are larger repositories of hazardous chemicals than hazardous chemical dumpsites. Large masses of chemicals are necessary to support the myriad human activities that take place in the industrial, commercial and residential sectors of cities (Diamond and Hodge, 2007). Vienna experienced a 78% increase in the use of construction materials from $0.1 \text{ m}^3/\text{c y}$ in the early 1900s to 2.4, 3.3 and $4.3 \text{ m}^3/\text{c y}$ in 1970, 1980 and 1990, respectively (Brunner and Rechberger, 2004). Currently, Vienna imports 12–18 t/c y in goods and products whereas solid waste removal is 3 t/c y. In Hong Kong, the import of plastics rose 400% to 3390 t daily from 1971 to 1997 (Kennedy *et al.*, 2007, among others).

A dramatic illustration of the mass of the chemical repository is the catastrophic release of a small proportion of this reservoir that occurred with the tragic destruction of the World Trade Center in New York City on 11 September 2001. In addition to the dreadful loss of life when the Twin Towers were destroyed, the destruction of these two towers resulted in the dispersal of 1.2 million tons of building debris, along with some fraction of the $\sim 130\,000$ gal of PCB-contaminated transformer oil from the two transformers housed in the buildings, and the dispersal of PBDEs contained in the estimated 50 000 personal and 300 main frame computers (Butt *et al.*, 2004).

On an on-going basis, $< 1\%$ of the total stock of POPs leaves a city annually. Although the fraction is small, the mass is large enough for cities to act as point sources of emissions to the surrounding environment (Offenberg and Baker, 1997; Simcik *et al.*, 1997; Diamond and Hodge, 2007) and hence act as a contaminant source to our food supply. As mentioned in Chapter 6, evidence of the ‘leakage’ of POPs from cities comes from urban–rural concentration gradients that range from 5 to 50 depending on the chemical, medium and nature of the built environment. Marked ‘urban pulses’ of PCBs, PBDEs and PAH have been measured in outdoor air, window films and soil whereby concentrations are correlated negatively with the distance from urban centres of Birmingham, UK, and Toronto, Canada (Gingrich and Diamond, 2001; Harner *et al.*, 2006; Harrad and Hunter 2006; Jamshidi *et al.*, 2007; Motelay-Massei *et al.*, 2005). Figures 8.3(a) to (d) illustrate how as one travels with the prevailing wind direction from the rural southwest (site 1 – 48 km upwind of the city centre) through the city centre of Birmingham, UK (site 7), to the rural

area north-east of Birmingham (site 11 – 31 km downwind of the centre); concentrations rise and fall in relation to proximity to the city centre. Other examples are cited in Chapter 6.

We next discuss this conceptual model as it applies to PCBs and brominated flame retardants (BFRs). PCBs have been discussed in Chapters 5, 6 and 7 and BFRs are the focus of Chapter 2.

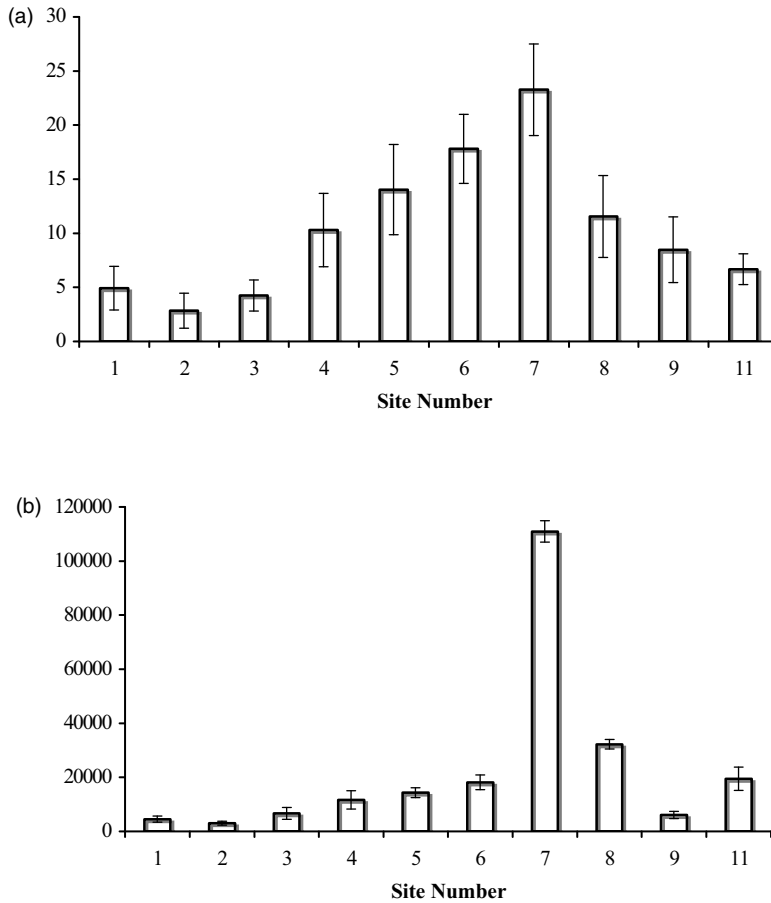

Figure 8.3 Annually averaged concentrations (error bars denote ± 1 standard deviation) at outdoor sites along a rural–urban transect across Birmingham, UK: (a) Σ PBDEs in air (pg/m^3); (b) Σ PBDEs in soil (pg/g); (c) Σ PCBs in air (pg/m^3) and (d) Σ PCBs in soils (ng/g). Soil concentrations normalized to soil organic carbon content. (a) and (b) Reprinted with permission from *Environmental Science and Technology*, Concentrations of Polybrominated Diphenyl Ethers in Air and Soil on a Rural–Urban Transect Across a Major UK Conurbation, by Stuart Harrad et al., **40**(15), 4548–4553. Copyright (2006) American Chemical Society. (c) and (d) Reprinted by permission from *Environmental Science and Technology*, Concentrations and Chiral Signatures of Polychlorinated Biphenyls in Outdoor and Indoor Air and Soil in a Major UK Conurbation, by Arsalan Jamshidi et al., **41**(7), 2153–2158. Copyright (2007) American Chemical Society)

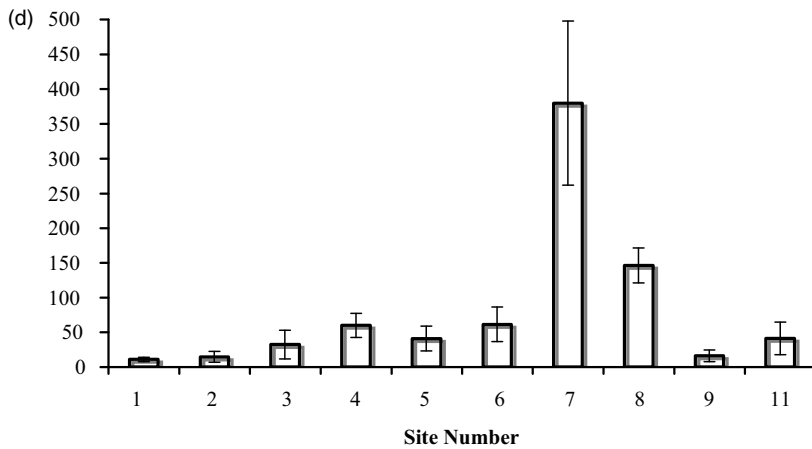
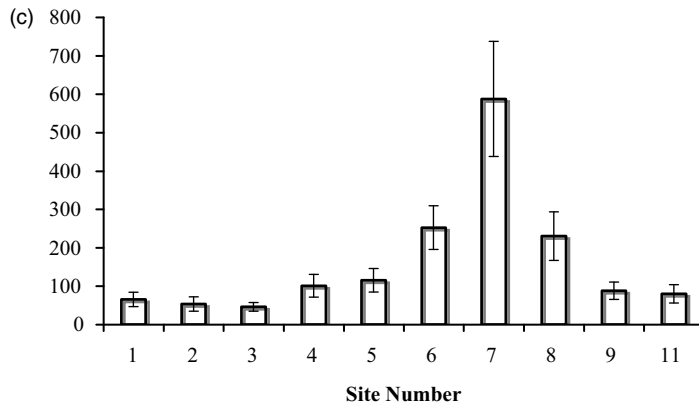

Figure 8.3 (Continued)

8.2.1 Case Study: PCBs

PCBs are the archetypal group of compounds for which our conceptual model applies. Large reservoirs of PCBs remain in use and in storage, particularly in cities and industrial areas. As well, large reservoirs of PCBs exist in the soils, sediments, water, vegetation and biota of the world. PCBs permeate our food supply. Our exposure comes from multiple routes and, because of their ubiquity, it is possible to reduce, but not eliminate, one's exposure to PCBs. Legislative action has reduced but not stopped releases of 'fresh' PCBs into the environment.

Most PCBs were added to reduce the flammability and increase the stability in mineral oils used as dielectric fluids in electrical transformers and capacitors, including the small transformers in fluorescent light fixtures (see Diamond *et al.*, 2009, among others). PCBs also saw widespread use as plasticizers in sealants in about one quarter of the many buildings built during the post-WWII construction boom in Europe and North America, as flame retardants in electrical wiring, and as a preservative in exterior paints and interior floor

finishes (Herrick *et al.*, 2004; Kohler *et al.*, 2005; Robson *et al.*, 2009; Rudel *et al.*, 2008). Other uses, but in much lower amounts, include in carbonless copy paper, adhesives, magnetic tapes, inks and coatings for wood. The uses in indoor and outdoor building sealants, in small lighting transformers, etc., have led to higher indoor than outdoor concentrations at ratios of 10 to up to 100 000 times (Bennett, 1983; see summary in Rudel and Perovich, 2009). Elevated indoor air concentrations are typically in buildings constructed from 1945 to the 1980s, after which PCBs were banned from new uses in many jurisdictions. It is suspected that older buildings from which PCBs have been removed still contain their memory in elevated air concentrations (Harrad *et al.*, 2009).

Ample evidence shows that cities are geographic ‘hot spots’ of PCBs (e.g. see Du *et al.*, 2008; Jaward *et al.*, 2004; Hafner and Hites, 2005; Totten *et al.*, 2006). A causal link between indoor and outdoor contamination was made by the correspondence between the chiral signatures of PCBs 95 and 149 in indoor and outdoor air, but not soil, in Birmingham UK (Robson and Harrad, 2004; Jamshidi *et al.*, 2007). Thus, it is not surprising that concentrations of PCBs are ~tenfold higher in urban than rural air, window films, soils and sediments (Gingrich *et al.*, 2001; Shen *et al.*, 2006; Jamshidi *et al.*, 2007; Wong *et al.*, 2009).

Many countries have a substantial reservoir of PCBs still in use and in storage, mainly in electrical transformers, capacitors and switches, but also as additives in wiring, sealants and other building applications. Chapter 5 discusses the magnitude of the reservoir in developing countries as a result of dumping from developed countries. Diamond *et al.* (2009) estimated that the reservoir of PCBs in Toronto, Canada (population 2.5 million), in the early 2000s was 437 tonnes (282–796 tonnes) or 687 mg/m² (444–1253 mg/m²). Most of the reservoir was within in-use and in-storage electric transformers and capacitors. Only 3% of the total reservoir was estimated to be in building sealants, but this is likely to be an underestimate because of the limitations of the sampling campaign that accessed only outdoor sealants at ground level (Robson *et al.*, 2009).

Several studies have estimated PCB release rates from cities ranging from 0.14 to 7.3 mg/m² y or 335 to 1600 mg/c y (Diamond *et al.*, 2009; Van Gerven *et al.*, 2004; Gasic *et al.*, 2009). For Toronto, this release rate is the equivalent of ~0.01–0.3% annually of the total documented stock. Thus, the reservoir is enormous relative to the release rate, particularly since the reservoir mass is underestimated.

As discussed in more detail in Chapter 6, 90–99% of PCBs emitted into a city’s air is blown downwind (Diamond *et al.*, 2009). Most of the fraction that is not blown downwind accumulates on impervious surfaces and from there is washed off into surface waters. For Toronto, this loading to surface waters is estimated to be a maximum of ~10 kg/y, but measurements by Robson *et al.* (2008) put the number at ~1 kg due to treatment of stormwater, which can remove 33–99% of PCBs (Pham and Proulx, 2007). Despite these high removal rates, wastewater treatment plant effluents are a significant source of PCB to surface waters (Ling, Diamond and Mackay, 1993).

After leaving the city, the PCBs travel regionally and globally (Hoff *et al.*, 1992; Simcik *et al.*, 1997; Gioia *et al.*, 2008) and have ample opportunity to enter into our food supply. Since at least the 1970s, PCB concentrations in predatory fish from the Great Lakes have exceeded the guideline for unlimited consumption of 105 ng/g ww (Bhavsar *et al.*, 2007). Fish worldwide have elevated PCB concentrations (Hites *et al.*, 2004). Indeed, PCBs are the test chemicals with which to examine food web bioaccumulation and

biomagnification processes (e.g. Norstrom *et al.*, 1988; Debruyne *et al.*, 2004; Gewurtz *et al.*, 2005). Trophic magnification factors that quantify the factor by which a chemical increases in concentration for each trophic transfer vary from 0.14 to 11 in aquatic food webs, depending on the particular food web (Kucklick *et al.*, 1996; Wu *et al.*, 2009; Helm *et al.*, 2008; Kelly *et al.*, 2008).

Numerous studies document PCBs in food supplies as seen from the perspective of human exposure (Davies, 1988; Schecter and Piskac, 2001). Due to their hydrophobicity, PCB concentrations track closely concentrations of fat and lipids, resulting in foods rich in animal lipids, such as fatty fish, cheese and meats, having the highest concentrations, as seen in Figure 8.4 (e.g. Watanabe *et al.*, 1979; Wilson *et al.*, 2003; Schaeffer *et al.*, 2006; Koizumi *et al.*, 2005).

As noted above, PCBs were banned from new production in the 1970s and 1980s. In response, we saw rapid declines of their concentrations in air, herbage, biota and foods (Alcock *et al.*, 1993; Sanders *et al.*, 1992; Jones *et al.*, 1992; DeVault *et al.*, 1996; Jeremiason *et al.*, 1998). This most likely reflects the fact that following the production ban, emissions dramatically declined from point sources of industrial manufacture and major uses. These declines, however, levelled off by the late 1980s and 1990s (Gewurtz and Diamond, 2003; DeVault *et al.*, 1996; Hickey *et al.*, 2006; Bhavsar *et al.*, 2007).

In contrast, emissions worldwide have continued (Figure 8.5; see Breivik *et al.* 2002b, 2007). In cities, contaminated industrial sites and buildings containing PCB-laden sealants have contributed to these emissions (Bignert *et al.*, 1998). Harrad and co-workers (2006) reported that concentrations of PCBs in indoor air in Birmingham, UK, had not declined significantly between 1997 and 1998 and 2003 and 2004. Instead, they had remained (at an average of 9 ng Σ PCB/m³) around 30–40 times higher than concentrations in outdoor air measured on the University of Birmingham campus, 3 km from central Birmingham (Currado and Harrad, 2000; Harrad and Mao, 2004; Jamshidi *et al.*, 2007).

Human exposure to PCBs from the 1970s to 1990s was ascribed to dietary sources with little attention paid to exposure indoors. The initial, high exposure estimates fell within a decade after the major bans on production and have since remained relatively constant

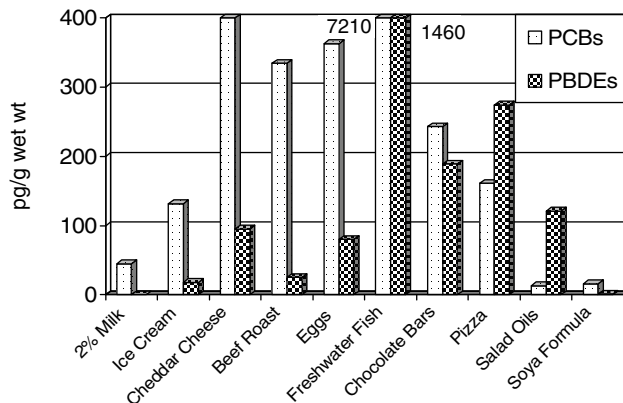

Figure 8.4 PCBs and PBDEs in selected foods analysed by Health Canada as part of its Total Diet Study (<http://www.hc-sc.gc.ca/fn-an/surveill/total-diet/concentration/index-eng.php>). PCBs and PBDEs were analysed in foods sampled in Vancouver, Canada, in 2002

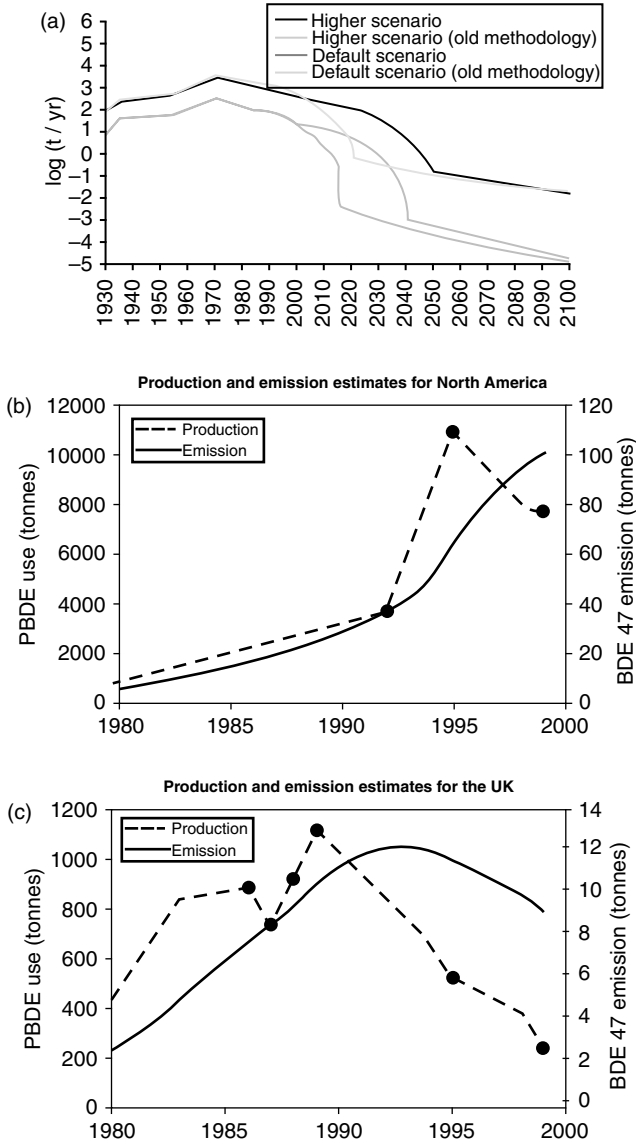

Figure 8.5 Temporal trends of global emissions of POPs: (a) PCBs estimated by Breivik et al. (2007) and (b) and (c) estimates of production and emissions of BDE-47 in North America and UK, respectively, by Alcock et al. (2003). ((a) Reproduced with permissions from Breivik et al., © (2007) Elsevier. (b) and (c) Reproduced with permission from Alcock et al., © (2003) Elsevier)

(Figure 8.6). Bennett (1983) calculated a mean PCB exposure of 24 µg/day for a US adult calculated from food concentrations and food intake rates measured in the US in the early to mid-1970s. He compared this with exposures of 5–100 µg/day estimated by WHO in 1976. About 10 years later, Davies (1988) estimated an adult PCB intake of 0.09 µg/day from a

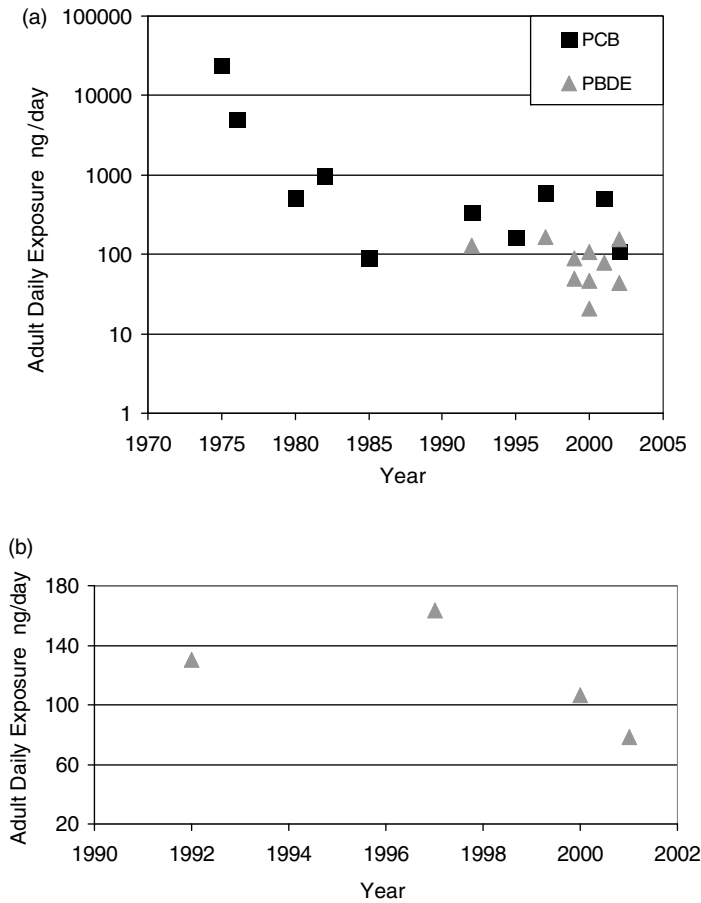

Figure 8.6 Temporal trends in adult dietary intake of PCBs and PBDEs. (a) Estimates were compiled from the following references for PCBs: Bennett, 1983; Davies, 1988; Koizumi *et al.*, 2005; DEFRA, 2007; Harrad *et al.*, 2004, 2009. PBDEs: Darnerud *et al.*, 2001; Kiviranta *et al.*, 2004; Jones-Otazo *et al.*, 2005; D'Silva *et al.*, 2006; Akutsu *et al.*, 2008. (b) PBDE intake estimated by D'Silva *et al.* (2006)

composite sample of meat, eggs, fruit and vegetables from Ontario, Canada. Her intake estimate did not include freshwater fish. Koizumi *et al.* (2005) reported that dietary intakes declined in Japan from 522.8 to 165.0 ng/day between 1980 and 1995. Dougherty *et al.* (2000) reported an adult intake rate in the US of 4.9–7 µg/day estimated from foods sampled in the early 1990s. The clear initial decrease followed by a levelling off in PCB exposure is perhaps best seen in the UK. Exposures to non-dioxin-like PCBs fell from 950 ng/day in 1982 to 340–500 ng/day between 1992 and 2001 (specifically the sum of congeners 18, 28, 31, 47, 49, 51, 52, 99, 101, 128, 138, 153, 170 and 180; DEFRA, 2007). Harrad *et al.* (2009) reported adult dietary exposure to PCBs from 1992 UK foods and 2002 Canadian foods as 340 and 112 ng/day, respectively. We note that this comparison of PCB exposures is based on different numbers of congeners, analytical methods and assumptions about food intake rates.

Fish, with the highest PCB concentrations of all foods (Figure 8.4), contribute significantly to total exposure, depending on intake rates. Evidence for the latter came from several studies in the 1980s and 1990s, which found that consumption of Great Lakes fish was related to PCB concentrations in human milk and body burdens (e.g. Schaeffer *et al.*, 2006). Moreover, children born to mothers who were frequent consumers of fish from Lakes Ontario and Michigan were found to have cognitive and behavioural impairments (e.g. Johnson *et al.*, 1998; Lonky *et al.*, 1996; Jacobson and Jacobson, 1996).

As dietary exposure declined from the peak in the 1970s and early 1980s, the *relative* importance of exposure from indoors increased. Harrad *et al.* (2009) estimated that PCBs in indoor air, and to a much lesser extent dust, contributed ~100 ng/day or half of the total exposure of a Canadian adult. The contribution from air was only 15% in UK, where indoor air concentrations are significantly lower than those in Canada.

What do we conclude from these seemingly disparate data? First, PCBs are intimately woven into the fabric of our cities constructed from 1945 to the 1980s – our homes, offices and schools. The global reservoir is not well documented but evidence suggests that it is large (Breivik *et al.*, 2002a, 2007; Diamond *et al.*, 2009). Second, leakage from a reservoir, which is suggested to be very low but nonetheless significant, ‘buffers’ our exposure via indoor air and our food supply.

What of temporal trends in the relative contribution to exposures portrayed in Figure 8.2? We hypothesize that exposures in the 1940s and 1950s would have been dominated by inhalation of indoor air (excluding occupational exposure). This is the first curve in Figure 8.2. By the 1970s, exposure would have shifted to food due to the biomagnification and persistence of PCBs. Exposure to the general population via inhalation and diet declined after legislative controls banned new production of PCBs in the 1970s and 1980s. This is the second curve in Figure 8.2. Our current situation suggests that both curves have the long tails of a logarithmic distribution. The long tail of indoor exposure dominates in North America with its higher indoor air concentrations whereas the long tail of diet dominates in the UK. The position of the dietary curve on the temporal scale should follow that of emissions constructed by Breivik *et al.* (2002a, 2007; Figure 8.5), but with a temporal lag due to the differing response times of air, water, sediment and soil (e.g. Mackay, 1989).

This analysis clearly points to the successes and weaknesses of legislative actions taken to control the use and releases of PCBs, which is the final component of our conceptual model (Figure 8.1). Legislative action taken by many developed countries in the 1970s and 1980s translated into clear and rapid initial declines in PCB concentrations in their countries’ environment and our food supply (noting the increase in PCB stocks in some developing countries that received the PCB waste from the developed world!). However, the relatively constant or slowly declining PCB concentrations globally since the late 1980s is of concern for highly exposed populations such as those in the Arctic and fish consumers, as well as those who reside in ‘PCB buildings’ (e.g. Van Oostdam *et al.*, 2005, Schaeffer *et al.*, 2006). Our deepening knowledge of ever more subtle health effects adds to our unease. The 166 countries that signed the Stockholm Convention are ‘committed’ to bringing their PCB stocks under ‘environmentally sound management’ (ESM) by 2028. However, as an international treaty, the Stockholm Convention is not legally binding on its signatory parties. Of the 159 countries that have signed, 35 have documented progress towards achieving this goal but 7 of these parties have reported challenges with sufficient capacity to document PCB inventories, let alone control or destroy their stocks. On the side of

optimism, PCB levels in the environment, which includes us, will continue to drop as countries adopt legislation to control and destroy PCBs, in compliance with the goals of the Stockholm Convention.

8.2.2 Case Study: Brominated Flame Retardants

As discussed in Chapter 2, BFRs have been used as additive and reactive flame retardants in myriad materials and products for over 30 years because of their effectiveness and low cost (Alcock and Busby, 2006). Similarly to PCBs, some BFRs, notably PBDEs, are widely dispersed in our environment and food supplies (e.g. Lorber, 2008; Pozo *et al.*, 2006; Ross *et al.*, 2009). Again, we use our conceptual model presented in Figure 8.1 to interpret temporal trends in concentrations and exposure. We also use it to discuss the role and effectiveness of policies and legislative controls. We focus our discussion on PBDEs for which most is known, with some information on HBCD and TBBPA and ‘newer’ BFRs such as bis(2,4,6-tribromophenoxy)ethane, or BTBPE, and (2-ethylhexyl)tetrabromophthalate, or TBPB (Stapleton *et al.*, 2008; Kolic *et al.*, 2009). We use the quotation marks for ‘newer’ because at least some of these BFRs have been in the marketplace for decades but have seen revived use as countries have banned penta- and octa-BDE and, most recently, deca-BDE (e.g. Alcock and Busby, 2006; Hoh *et al.*, 2006; Stapleton *et al.*, 2008).

BFRs such as PBDEs and HBCD have been used as additive flame retardants that are not chemically bonded to the plastic polymer and are thus available for volatilization, in contrast to TBBPA, which is used mostly as a reactive flame retardant that is chemically bonded with the polymer. The concentrations of BFRs associated with treated products such as electronic goods are typically at the ppm to percent level (Schlummer *et al.*, 2006; Petreas and Oros, 2009). In particular, BFRs can be added at up to 10% by weight to polystyrene (PS), high impact polystyrene (HIPS) and acrylonitrile butadiene styrene (ABS), the polymers most commonly used in TV, telephone and other visual display unit casings (Delgado *et al.*, 2007). The list of materials and products that may contain BFRs is long, e.g. upholstery fabrics, carpets, furniture and car seating casings for TVs, photocopiers, computers and other electronic and electrical goods. HBCD may be added to blown foam used for structural insulation. TBBPA is used in epoxy resins, HIPS, ABS and terephthalate (PET) plastics used in printed circuit boards, electronic casings and other uses (Morf *et al.*, 2003).

The reservoir of materials and goods containing BFRs is enormous. Much of the reservoir is in the plastics and circuit boards of electronic and electrical equipment (EEE). It is an astounding business success and a potential WEEE (waste electronic and electrical equipment or e-waste) disaster that Apple Inc. sold 1 million iPhones in less than three months in 2007. In the same year, Apple Inc. sold its 100 millionth iPod (<http://www.apple.com/pr/library/2007/04/09ipod.html>; accessed 30 March 2009). The magnitude of the EEE reservoir is starkly illustrated by statistics on the generation of WEEE, which is, of course, the outflow of the stock of EEE. WEEE from the US in 2001 was estimated at 2.26 million tonnes, 6 million tonnes from the EU in 1998, 1.1 million tonnes from Germany in 2005, 6.77 million tonnes from Korea in 2004 and 1.5 million tonnes from France in 2004 (Nnorom and Osibanjo, 2008). Worldwide, UNEP has estimated that global generation of WEEE is 20–50 million tonnes annually (Burke, 2007; Leung *et al.*, 2007). Small products or sWEEE comprised of household appliances (hair dryers, coffee makers, vacuum

cleaners, telephones, mobile phones, TVs, screens, printers, radios, photocopy machines) may be less in weight than large products how sWEEE typically contains higher levels of Br and thus presumably brominated organics (Morf *et al.* 2007).

The devastating effects of the magnitude of WEEE and its burden of BFRs (and other toxic compounds) are borne most acutely by developing nations who receive much of the WEEE (see Chapter 5). Moreover, the problem may get worse before it gets better as electronic products have an ever-shorter lifespan and global sales increase (Delgado *et al.*, 2007). In addition to WEEE, BFRs have been used extensively in the vehicle industry. In 2005, an estimated 621 000 tonnes of autoshredder wastes (including fridges, ovens, etc.) and 1200 million tonnes of discarded consumer electronics containing high ppm to percent levels of PBDEs (mostly BDE-209 but also other congeners including BDE-47 and -99) were generated in California alone (Petreas and Oros, 2009).

Morf *et al.* (2003) conducted a detailed material flow analysis of PBDEs and TBBPA in Switzerland as of the late 1990s. They calculated that over the past 20 years, a reservoir of approximately 12 000 tonnes of BFRs has been amassed in Switzerland. In the late 1990s the reservoirs of penta- and deca-BDE were decreasing but that of TBBPA was increasing (Figure 8.7). We summarize their results for octa- and deca-BDE and TBBPA.

According to Morf and co-workers (2003), a total of 6000 tonnes of octa-BDE was produced globally in 1991, then falling to 3800 tonnes in 1999. Its use was primarily as a flame retardant in ABS plastic in electrical and electronic appliances, as well as in thermoplastic polyesters, polyamides and latex textile coverings. Over two decades, the stock of octa-BDE rose to ~680 tonnes in Switzerland, of which ~42% was in TVs, 21% in cars, 10% in building materials and 16% in plugs and switches. Morf *et al.* (2003) estimated that the stock is declining with inputs of 22 t/y and outputs of 62 t/y, which, in 13–18 years, would shift the main reservoir of octa-BDE to waste management (e.g. landfills) rather than products. The fastest decline was expected in TVs (36% of waste stream), electronic data processing equipment and other office equipment (26%). They also estimated that electronic and electrical goods and materials in private households accounted for the greatest source of nonpoint source emissions to the environment. The nonpoint emissions were estimated at 0.4 t/y or ~0.01% of the total stock annually.

Deca-BDE has had the largest market share of the three PBDE mixtures, particularly after the restrictions on production and new uses of penta- and octa-BDE in the EU and North America in 2004. Deca-BDE has been used in high impact polystyrene (HIPS) plastics for the casings of electronic and electrical appliances and products. Morf *et al.* (2003) estimated that the stock of deca-BDE in Switzerland was 5600 tonnes with 320 tonnes added (new products) and 370 subtracted (disposal) from the stock annually in the late 1990s. The largest percentage of this flow (45%) was in electronic and electrical finished products, of which electronic data processing equipment and household electrical appliances accounted for 17 and 11%, respectively. In contrast to the flows, the largest percentages of the stock of deca-BDE were in building materials (30% plastic sheeting and insulating foams) and cars (also 30%). In comparison, 20% of the stock was in the more rapidly replaced household electronic and electrical household appliances, which they estimated comprised 44% of the 370 t/y waste stream.

The stock of TBBPA of 5600 tonnes is similar to that of deca-BDE, with additions and removals in the late 1990s of 1130 and 550 t/y, respectively. Thus, the reservoir was

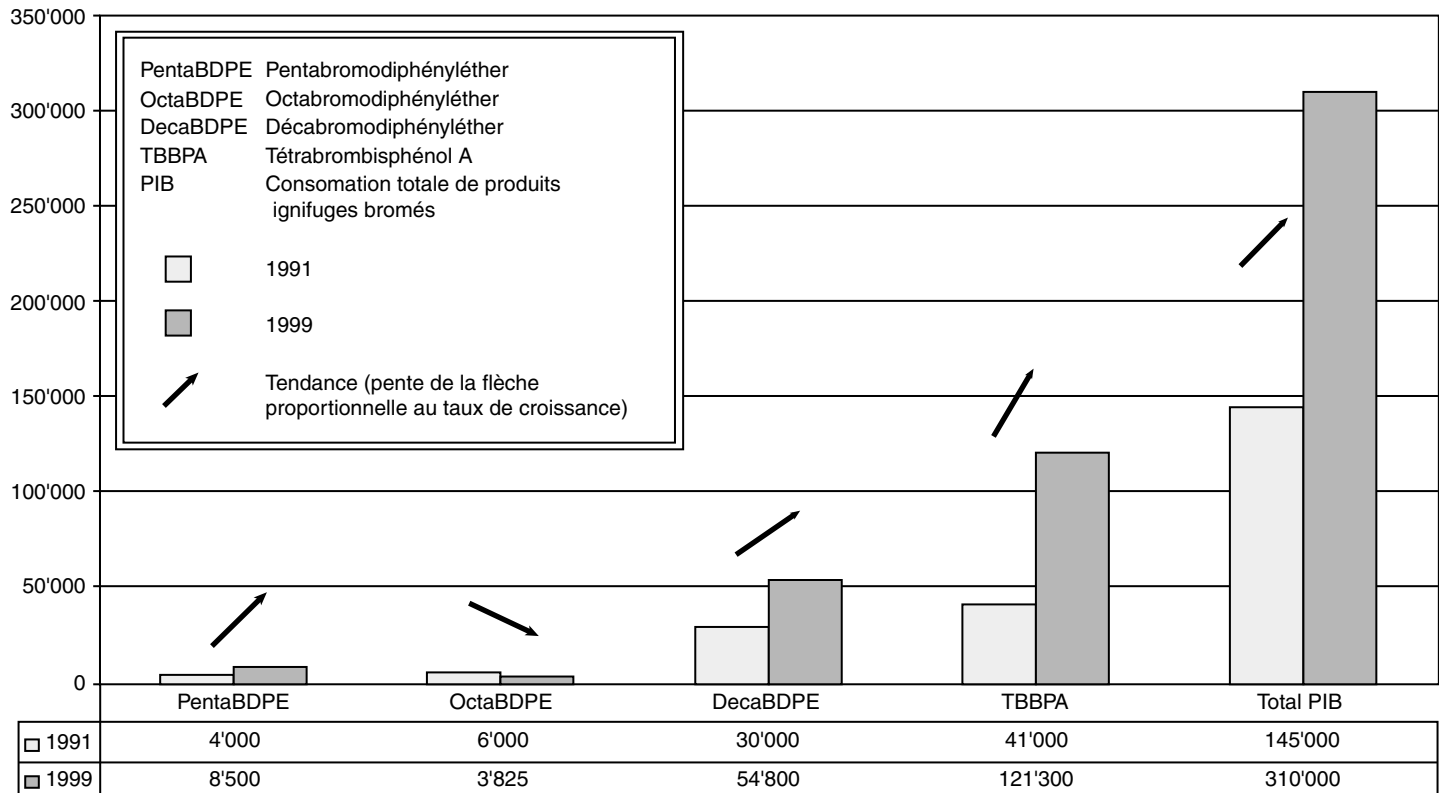

tonnes per year

Figure 8.7 Consumption of BFRs in Switzerland estimated by Morf et al. 2003. (Reproduced with permission from Morf et al.)

estimated to be expanding at a rate of 180 t/y. In the reservoir, 40% was in semi-finished products such as building materials and 60% in finished goods such as appliances. Consistent with its use, mostly as a reactive flame retardant, nonpoint emissions of TBBPA were estimated at only 0.0005% of the reservoir annually.

As discussed in Chapter 7, BFRs are released from consumer products into the indoor environment. The clear lines of evidence of emissions into the indoor environment are direct emission measurements, modelled emission estimates and numerous studies documenting higher indoor than outdoor air concentrations (e.g. Kemmlein *et al.*, 2003; Wilford *et al.*, 2004; Stapleton *et al.*, 2005; Harrad *et al.*, 2008a; Zhang *et al.*, 2009). Moreover, we have clues that electronic goods are likely to be greater sources than other products and materials (Hazrati and Harrad, 2006; Allen *et al.*, 2008). Using a fugacity-based mass balance model, Zhang *et al.* (2009) estimated emission rates of Σ_7 BDE (BDE-28, 47, 66, 100, 99, 154, 153) from one computer in one room to be 5–35 ng/h or 25–175 ng/m² day (m² of office area), which is of similar magnitude to that reported by Kemmlein *et al.* (2003) of 10.7 ng/m² h from a TV housing (m² of TV casing) or 21 ng/unit h from a printed circuit board. Batterman *et al.* (2009) estimated a mean release rate of 480 ng/m² day of Σ_{20} PBDE from US houses including garages, based on measured concentrations in dust and HVAC filters. Further, they estimated that the release rate was 0.1–0.7% annually of the total stock.

Zhang *et al.* (2009) also estimated that for a particular room examined in a modelling case study, from 30 to 50% of emissions were released outdoors by ventilation. In contrast, 30–60% was lost via dust removal (e.g. vacuuming). In many localities, dust removal geographically relocates, but does not destroy, the chemical. In contrast, Batterman *et al.* (2009) estimated releases to outside air of 4.6 mg/house y or ~13% of indoor emissions of 35 mg/house y.

Outdoor air concentrations of BFRs are 10 to 100 times lower than those indoors (Harrad *et al.*, 2004; Shoeib *et al.*, 2004; Wilford *et al.*, 2004). We reasonably postulate that the outdoor concentrations, especially those in cities, are maintained by a constant emission from indoors. The other main sources of BFRs outdoors are industrial sites where BFRs are synthesized and are used to make finished products and sites that handle wastes containing BFRs (Hale *et al.*, 2002; Hoh and Hites, 2005; Cahill *et al.*, 2007). As with PCBs, the signature shifts from the full range of halogenated congeners emitted from indoor sources to less halogenated, more volatile and mobile congeners outdoors, with the notable exception of the surprising abundance of deca-BDE (Butt *et al.*, 2004; Venier and Hites, 2008).

Aggregate emissions of BFRs from cities are surprisingly similar to that estimated to be released from the indoor environment. The estimate of indoor emissions by Zhang *et al.* (2009) of 25–175 ng/m² day for Σ_7 BDE (not including deca-BDE) was relatively close to that estimated by Jones-Otazo *et al.* (2005) of 200–900 ng/m² day Σ_{10} BDE (not including BDE-209) coming from the City of Toronto (both rates are per m² of flat area). In turn, the emission rate estimated by Jones-Otazo *et al.* (2005), expressed as 19–82 mg/c y, was ~3–12 times greater than the 7 mg/c y for Denmark estimated by Palm (2001) and 100–300 times greater than ~0.3 mg/c y for penta- and octa-BDE estimated by Morf *et al.* (2003). That the emission estimates are within a factor of ~100 is surprising since they were derived using different methods – Palm and Morf *et al.* based their emissions on material flow analyses whereas Jones-Otazo *et al.* derived their estimates from a chemical mass balance model for a city.

Over 95% of penta- and octa-BDEs emissions to the air of cities are estimated to be blown downwind from a city, with the remainder degrading or being transferred to soils and surface waters (Jones-Otazo *et al.*, 2005). Air measurements confirm both the importance of cities as ‘hotspots’ or point sources to the surrounding environment and regional atmospheric transport. Urban–rural gradients of PBDEs vary from 3 to 6 (Hoh and Hites, 2005) to up to 100-fold (Jaward *et al.*, 2004). From populated centres, BFRs, including the very low volatility deca-BDE, undergo regional and long-range transport (Wania and Dugani, 2003; Breivik *et al.*, 2006; de Wit *et al.*, 2006).

In addition to the movement of BFRs via atmospheric transport, BFRs have ramified through the global environment through the production, use and disposal of products (see Chapter 5). Significant production of EEE (and hence the use of BFRs) takes place in developing countries such as the Ukraine, Mexico and countries in Asia where minimal waste management is practised. Unfortunately there is a dearth of information describing the consequences of EEE production in these countries. More information has been documented on WEEE. UNEP has quoted that 80% of computer waste has been exported to China as illegal imports for ‘recycling’ (Burke, 2007). As China restricts imports of electronic waste, other countries such as Nigeria and Ghana now host disposal sites (Nnorom and Osibanjo, 2008; Schmidt, 2006). Recent reports suggest that waste electronics disposal/recycling centres in developing countries are a major source of emissions and exposure to BFRs and other chemicals to the workers, which include children, dismantling the products with no protection (Qu *et al.*, 2007; Huo *et al.*, 2007). These ‘recycling’ centres are also emission sources of POPs to the local environment and, consequently, others in nearby communities (Bi *et al.*, 2007; Wu *et al.*, 2008).

In the environment, PBDEs bioaccumulate and biomagnify in food webs, although to a lesser extent than PCBs due the metabolic debromination of higher brominated congeners (Stapleton *et al.*, 2004, 2006). Trophic biomagnification factors vary from 0.26 to 4.47 for Σ PBDEs (Wu *et al.*, 2009; Wan *et al.*, 2008; Kelly *et al.*, 2008). While the metabolic debromination of PBDEs in aquatic biota reduces trophic transfer of the higher brominated congeners, it produces lower brominated congeners that are available for uptake and biomagnification (Gandhi *et al.*, 2006; Shaw *et al.*, 2009).

We next turn to examine exposure to BFRs and particularly PBDEs. This examination is complicated by the year and geographic location of the analysis because of the rapid changes in environmental concentrations and differing usage rates of BFRs according to country. However, it is this complication that led us to hypothesize that the route of exposure can shift over time as a persistent chemical is released from its point of use (and early exposure) to outdoors and from there to our food supply.

Early exposure assessments focused on diet and in particular fish that had elevated concentrations relative to other animal products (Kiviranta *et al.*, 2004; Ohta *et al.*, 2002). These assessments were informed by our experience with PCBs and PCDD/F for which diet was clearly the main exposure route. The exposure assessments pointed to a missing source since dietary intake of PBDEs did not seem to account for some elevated levels being measured in breast milk or blood serum. A particular puzzle was the source of PBDEs to the few women with up to 1000 times higher concentrations in their breast milk relative to others. For example, Ryan (2004) reported that concentrations from 98 Canadian women ranged from 23 to 38 240 ng/kg whole milk with an arithmetic mean and median of 2400 and 880 ng/kg whole milk. Another puzzle was the ~tenfold

higher breast milk concentrations in North American than in European women (e.g. Betts, 2002).

Stapleton *et al.* (2005) were the first to find elevated levels of PBDEs in house dust and to posit that exposure to dust could be an important exposure route. This was followed by confirmation of dust as the dominant exposure route to PBDEs and that diet was secondary for North Americans (Jones-Otazo *et al.*, 2005; Lorber, 2008). Dust, as the main exposure route, was able to account for those women with much higher PBDE concentrations and some of the geographic differences seen among continents (Harrad *et al.*, 2008b). Wu *et al.* (2007) confirmed the dust exposure hypothesis by finding a clear relationship between PBDE concentrations in the breast milk and household dust for 46 mothers in the Northeast US. Further, Zota *et al.* (2008) found that blood serum levels of residents of several counties in California were twofold higher than that in the US as a whole, and concluded that this was consistent with 4–10 times higher dust concentrations. Betts (2008) provides an excellent overview of the subject.

Another aspect of dust being the main exposure route is that toddlers have greater exposure than adults. Jones-Otazo *et al.* (2005) estimated that the mean exposure of toddlers (0.5–2 years) was 10 times greater than that of adults because of toddlers' higher dust ingestion rates. Similarly, Lorber (2008) estimated that children (1–5 years) had exposures 6 times greater than that of adults, again due to dust ingestion. Support of this relationship was provided by Fischer *et al.* (2006), who measured PBDE concentrations 2–5 times higher in a toddler than adults in a family from California.

Complications with understanding exposure also arise due to geographic and lifestyle differences. Higher PBDE dust concentrations in the UK and California and potentially higher exposures have been related to the high standards of flame retardancy in these jurisdictions (Harrad *et al.*, 2008b; Zota *et al.*, 2008), although commodities manufactured to meet the Californian standard are marketed throughout North America. Those with lifestyles involving greater usage of PBDE-containing products may have higher body burdens than those that do not (LaKind *et al.*, 2008).

Diet is also an important route of exposure to PBDEs, particularly for individuals for which indoor exposures are low and/or fish is an important food. For adults, dietary contributions vary from 44 ng/day in Finland (2002 food samples analysed for BDE-47, 99, 100, 153, 154; Kiviranta *et al.*, 2004) and 21–46 ng/day in Japan (2000 food samples analysed for penta- and deca-BDE; Akutsu *et al.*, 2008) to 90 ng/day in the UK (1999 food samples for BDE-47, 99, 100, 153, 154; Harrad *et al.*, 2004) and 155 ng/day in Canada (2002 food samples for 18 congeners not including deca-BDE; Jones-Otazo *et al.*, 2005). Of particular concern is the estimated high exposure to breast-fed infants of a mean of 1965 (24–28 680) ng/day (Jones-Otazo *et al.*, 2005).

If we look at dietary exposure more closely, we see that indoor levels could play a role there too. Fish often have the highest concentrations of PBDEs in food baskets (e.g. Jones-Otazo *et al.*, 2005; Schechter *et al.*, 2008). However, when we compare levels of PBDEs and PCBs in a market basket, we find that processed foods, such as ready-made pizza, cooking oils, sweets, beverages and spices, have relatively higher concentrations than foods that undergo limited processing (e.g. fruit) (Kiviranta *et al.*, 2004; Jones-Otazo *et al.*, 2005; Akutsu *et al.*, 2008). This is illustrated in Figure 8.4, which shows that foods sampled in Vancouver, Canada, by Health Canada in 2002 had higher concentrations of PCBs in milk, eggs and meat due to, presumably, food chain transfer, versus pizza and salad oils that were

higher in PBDEs, which we suggest is due to direct transfer from indoor sources during processing.

The final component of the conceptual model is the temporal dimension whereby we shift from exposure near the point of chemical use and release to exposure through our food supply via environmental pathways. We postulated this for PCBs but lacked data on human exposure during peak usage. However, we are now in the midst of this shifting temporal trend for PBDEs. The temporal trends for PBDEs are discussed in Chapter 2.

Sweden first took action to limit PBDEs in 1997 and shortly thereafter saw decreases in concentrations in breast milk (Betts, 2002). Meanwhile, concentrations continued to rise in the breast milk and biota of other countries with concentrations about tenfold higher in North America (Hites, 2004). There are now indications that the EU's cessation of the manufacturing and new use of the penta- and octa-BDE formulations in 2004 has resulted in a decline in contemporary environmental concentrations and exposure. D'Silva *et al.* (2006) monitored UK dietary exposure to Σ PBDEs (excluding BDE-209) between 1992 and 2003 (Figure 8.6(b)). They estimated that exposure peaked in 1995–1996, and by 2003 had fallen to less than 1992 levels. Likewise, the recent decline in UK consumption of HBCD has been mirrored in a fall in concentrations of HBCDs in marine mammals in UK waters (Law *et al.*, 2008). Continued monitoring of environmental concentrations is required if we are to establish whether the encouraging pace of such initial improvements are reflected in the long term, or whether – as appears to have occurred with PCBs – it slows substantially as relatively more emissions originate from materials and products with long replacement times than emissions from the *de novo* synthesis and the manufacturing of PBDE-containing products. Moreover, we have yet to determine the importance of the enormous environmental reservoir of PBDEs, notably BDE-209 (Ross *et al.*, 2009). Thus, at this time we have evidence that human exposures are declining in countries that have banned some PBDEs and that do not have extensive recycling of PBDE-containing products. We cannot yet compare rates of decline in our indoor exposures, over which we have some control, versus diet and our food supply, over which we have minimal control.

As discussed above, a factor that complicates time trends with respect to PBDEs is their tendency to debrominate to lower brominated congeners. Thus, it is not unreasonable to hypothesise that, over time, the current reservoir of deca-BDE, as well as octa- and even penta-BDE will be transformed, with a resultant cascading enhancement of human exposure to the more bioavailable and toxic lower brominated congeners (Ross *et al.*, 2009). Preliminary evidence to support this hypothesis is already emerging. Schenker *et al.* (2008) have estimated that approximately 13 and 2% of penta- and tetra-BDE, respectively, in the environment is attributable to the degradation of deca-BDE. Shaw *et al.* (2009) have documented the contribution of degradation products of BDE-209 to the body burdens in Northwest Atlantic Harbour seals. Thomsen *et al.* (2005) have reported a rise in the relative contribution of the hexabrominated congener BDE-153 to human body burdens. In the future, we hypothesize that further such changes in the congener pattern of human exposure may emerge, driven by progressive debromination of the higher brominated octa- and deca-BDE commercial formulations released into the environment.

As discussed in Chapter 2, several jurisdictions have passed legislation to restrict or ban PBDEs. However, the devil is in the details of the legislation. Passed in 2004, the EU has the tightest restrictions on penta- and octa-BDEs, which were banned from production and consumer products. Several large corporations have complied with this ruling although

compliance is not independently monitored. The US EPA brokered a voluntary agreement in 2004 with two manufacturers of penta- and octa-BDE to discontinue their production. It is not clear what provisions exist for controlling penta- and octa-BDE in goods imported into the US. Several US states (e.g. California, Illinois, Minnesota, New York, Hawaii) have banned these two mixtures (CELA and Lowell Center for Sustainable Production, 2009). Canada banned the production, importation and use of tetra- to hexa-BDEs in 2006, but the legislation did not provide for a ban on imported finished goods containing these congeners. In July 2008 the EU upheld the ban on the use of deca-BDE in electrical and electronic goods. Canada followed suit in 2009 by banning deca-BDE in electronics and electrical equipment by 2011, based on the finding that deca-BDE can degrade to lower brominated congeners.

Hopefully the tide will soon ebb of WEEE, including the stock that still contains PBDEs and newer BFRs from Europe and North America, which reaches the shores of developing countries for 'recycling'. The EU introduced WEEE legislation in July 2007 to promote the sustainable disposal of such goods and thus minimize associated POPs emissions. Comparable legislative initiatives are slow to emerge in North America and other parts of the globe. Canada has refused to take action nationally, leaving the individual provinces to enact their own legislation. Ontario, the most populous province in Canada, has taken such action in 2009. A similar situation exists in the US where several US states, including Illinois, Minnesota, Pennsylvania and New York, have enacted legislation providing for the management of obsolete electronics (CELA and Lowell Center for Sustainable Production, 2009).

8.3 Discussion

Figure 8.2 illustrates what *has* happened with PCBs and what we hypothesize *will* occur with recent and current-use POPs such as PBDEs, HBCD and potentially the latest emerging flame retardants, such as bis(2,4,6-tribromophenoxy)ethane, or BTBPE, and decabromodiphenylethane, or DBDPE (Hoh and Hites, 2005; Stapleton *et al.*, 2008; Kolic *et al.*, 2009; Ismail *et al.*, 2009). At the present time, it appears that we are somewhere on the left of the graph for PBDEs, which began major production some time in the 1970s, and further to the right for PCBs, where the corresponding date is 1945 (e.g. Koizumi *et al.*, 2005). Moreover, for PBDEs it is likely that Europe is further to the right and North America further to the left, due to the earlier legislative restrictions of the penta- and octa-BDEs in Europe and greater use of these mixtures in North America (Alcock and Busby, 2006).

We noted in the introduction to this chapter that the current policy paradigm has successfully reduced direct emissions of several POPs to the outdoor environment from industry, thereby producing initial rapid decreases in nearby outdoor concentrations. The Stockholm Convention strives to implement international controls over 12 POPs (see Chapter 1) among the 166 countries that signed in 2001. The EU and North America have legislative frameworks that screen for chemicals in commerce according to their persistence, bioaccumulative potential and toxicity. However, there are loopholes in policies and legislation, including REACH, that are now being implemented in the EU. Current legislation in the EU and North America does not address POPs in imported goods

and nor does it address the reservoir of goods in our built environment that contain banned or controlled chemicals.

At the same time, we note the magnitude of the challenge to control the worldwide dispersal into ecosystems of POPs that are in storage (e.g. PCBs) and in use (DDT, lindane, PCBs, PBDEs, HBCD), not to mention those already circulating in the environment. Some countries continued to produce POPs after production bans have been enacted in other jurisdictions (e.g. the case of Russia producing PCBs well into the 1990s; Breivik *et al.*, 2002a). In other cases we do not know production rates or inventories of banned POPs (Breivik and Alcock, 2002).

For PCBs and PBDEs, the masses produced are sobering given the longevity of the chemicals. A total of 1.325 million tonnes of PCBs were produced globally over 60 years from the early 1930s to the 1990s (Breivik *et al.*, 2007). US production by Monsanto increased 57% from 1960–1964 to 1965–1970 (Voldner *et al.*, 1986). We do not know the total global reservoir of PBDEs. Global production of BFRs in 2001 was > 200 000 tonnes. Of this, PBDE production was 67 440 tonnes plus 119 700 and 16 700 tonnes of TBBPA and HBCD, respectively, with production increasing at 4–8% annually (Birnbaum and Staskal, 2004; Morf *et al.*, 2005, among others). Alcock *et al.* (2003) estimated global production of 100 000 tonnes of penta-BDE between 1970 to the early 2000s (Figure 8.5(b)). Even if less than 0.1% of the reservoir is released, this seems sufficient to result in our exposure ‘today’ through indoor sources and ‘tomorrow’ through our food supply.

Can further legislation be enacted to control the flow of POPs in materials and goods? Even if legislation is enacted to control POPs in existing reservoirs, do we have the know-how, resources and capacity to quantify, collect and dispose of the reservoir and to replace the materials and products with ‘safe’ alternatives? Perhaps not, given our long list of pressing societal priorities. Rather, we should turn the end of the telescope towards ourselves to ask how we can reduce our rapacious appetite for the materials and products that populate the technosphere, with the co-benefits of reducing POPs in our homes, schools and workplaces and moving towards a more sustainable future!

References

- Akutsu, K., Takatori, S., *et al.* (2008) Dietary intake estimations of polybrominated diphenyl ethers (PBDEs) based on a total diet study in Osaka, Japan. *Food Additives and Contaminants, Part B – Surveillance*, **1**(1): 58–68.
- Alcock, R. E., Busby, J. (2006) Risk migration and scientific advance: the case of flame-retardant compounds. *Risk Analysis*, **26**(2): 369–381.
- Alcock, R. E., Johnston, A. E., *et al.* (1993) Long-term changes in the polychlorinated biphenyl content of United Kingdom soils. *Environmental Science and Technology*, **27**(9): 1918–1923.
- Alcock, R. E., Sweetman, A. J., *et al.* (2003) Understanding levels and trends of BDE-47 in the UK and North America: an assessment of principal reservoirs and source inputs. *Environment International*, **29**(6): 691–698.
- Allen, J. G., McClean, M. D., *et al.* (2008) Linking PBDEs in house dust to consumer products using X-ray fluorescence. *Environmental Science and Technology*, **42**(11): 4222–4228.
- Ashwood, P., Schauer, J., *et al.* (2009) Preliminary evidence of the *in vitro* effects of BDE-47 on innate immune responses in children with autism spectrum disorders. *Journal of Neuroimmunology*, **208** (1–2): 130–135.

- Batterman, S. A., Chernyak, S., *et al.* (2009) Concentrations and emissions of polybrominated diphenyl ethers from U.S. houses and garages. *Environmental Science and Technology*, **43**(8): 2693–2700.
- Bennett, B. G. (1983) Exposure of man to environmental PCBs – an exposure commitment assessment. *Science of the Total Environment*, **29**(1–2): 101–111.
- Betts, K. S. (2002) Rapidly rising PBDE levels in North America. *Environmental Science and Technology*, **36**(3): 50A–52A.
- Betts, K. S. (2008) Unwelcome guest – PBDEs in indoor dust. *Environmental Health Perspectives*, **116**(5): A203–A208.
- Bhavsar, S. P., Jackson, D. A., *et al.* (2007) Are PCB levels in fish from the Canadian Great Lakes still declining? *Journal of Great Lakes Research*, **33**: 592–605.
- Bi, X., Thomas, G. O., *et al.* (2007) Exposure of electronics dismantling workers to polybrominated diphenyl ethers, polychlorinated biphenyls, and organochlorine pesticides in South China. *Environmental Science and Technology*, **41**(16): 5647–5653.
- Bidleman, T. F., Leone, A. D., *et al.* (2006) Emission of legacy chlorinated pesticides from agricultural and orchard soils in British Columbia, Canada. *Environmental Toxicology and Chemistry*, **25**(6): 1448–1457.
- Bignert, A., Olsson, M., *et al.* (1998) Temporal trends of organochlorines in Northern Europe, 1967–1995. Relation to global fractionation, leakage from sediments and international measures. *Environmental Pollution*, **99**(2): 177–198.
- Birnbaum, L. S., Staskal, D. F. (2004) Brominated flame retardants: cause for concern? *Environmental Health Perspectives*, **112**(1): 9–17.
- Boucher, O., Muckle, G., *et al.* (2009) Prenatal exposure to polychlorinated biphenyls: a neuro-psychologic analysis. *Environmental Health Perspectives*, **117**(1): 7–16.
- Breivik, K., Alcock, R. (2002) Emission impossible? – The challenge of quantifying sources and releases of POPs into the environment. *Environment International*, **28**(3): 137–138.
- Breivik, K., Sweetman, A., *et al.* (2002a) Towards a global historical emission inventory for selected PCB congeners – a mass balance approach. 1. Global production and consumption. *Science of the Total Environment*, **290**(1–3): 181–198.
- Breivik, K., Sweetman, A., *et al.* (2002b) Towards a global historical emission inventory for selected PCB congeners – a mass balance approach. 2. Emissions. *Science of the Total Environment*, **290**(1–3): 199–224.
- Breivik, K., Sweetman, A., *et al.* (2007) Towards a global historical emission inventory for selected PCB congeners – a mass balance approach. 3. An update. *Science of the Total Environment*, **377**(2–3): 296–307.
- Breivik, K., Wania, F., *et al.* (2006) Empirical and modeling evidence of the long-range atmospheric transport of decabromodiphenyl ether. *Environmental Science and Technology*, **40**(15): 4612–4618.
- Brunner, P., Rechberger, H. H. (2001) Anthropogenic metabolism and environmental legacies. In *Encyclopedia of Global Environmental Change* (ed T. Munn). John Wiley & Sons, Ltd, Chichester, UK.
- Brunner, P., Rechberger, H. H. (2004) *Practical Hand-book of Material Flow Analysis*. CRC Press, Boca Raton, Florida.
- Burke, M. (2007) The gadget scrap heap. *Chemistry World*, **4**(6): 44–48.
- Butt, C. M., Diamond, M. L., *et al.* (2004) Semivolatile organic compounds in window films from lower Manhattan after the September 11th World Trade Center attacks. *Environmental Science and Technology*, **38**(13): 3514–3524.
- Cahill, T. M., Groskova, D., *et al.* (2007) Atmospheric concentrations of polybrominated diphenyl ethers at near-source sites. *Environmental Science and Technology*, **41**(18): 6370–6377.
- CELA and Lowell Center for Sustainable Production (2009) The challenge of emerging substances of concern in the Great Lakes Basin: a review of chemicals policies and programs in Canada and the United States. International Joint Commission, Multi-Board Work Group on Chemicals of Emerging Concern in the Great Lakes Basin.
- Currado, G. M., Harrad, S. (2000) Factors influencing atmospheric concentrations of polychlorinated biphenyls in Birmingham, UK. *Environmental Science and Technology*, **34**(1): 78–82.

- Darnerud, P. O., Eriksen, G. S., *et al.* (2001) Polybrominated diphenyl ethers: occurrence, dietary exposure, and toxicology. *Environmental Health Perspectives*, **109**: 49–68.
- Davies, K. (1988) Concentrations and dietary-intake of selected organochlorines, including PCBs, PCDDs and PCDFs in fresh food composites grown in Ontario, Canada. *Chemosphere*, **17**(2): 263–276.
- Debruyne, A. M. H., Ikononou, M. G., *et al.* (2004) Magnification and toxicity of PCBs, PCDDs, and PCDFs in upriver-migrating Pacific salmon. *Environmental Science and Technology*, **38**(23): 6217–6224.
- DEFRA (2007) National Implementation Plan for the Stockholm Convention on *Persistent Organic Pollutants*. United Kingdom of Great Britain and Northern Ireland, Department of the Environment, Food and Rural Affairs, pp. 37–38.
- Delgado, C., Barruetabena, L., *et al.* (2007) Assessment of the environmental advantages and drawbacks of existing and emerging polymers recovery processes. Luxembourg, European Commission, Joint Research Centre, Institute for Prospective Technological Studies.
- DeVault, D. S., Hesselberg, R., *et al.* (1996) Contaminant trends in lake trout and walleye from the Laurentian Great Lakes. *Journal of Great Lakes Research*, **22**(4): 884–895.
- de Wit, C. A., Alae, M., *et al.* (2006) Levels and trends of brominated flame retardants in the Arctic. *Chemosphere*, **64**(2): 209–233.
- Diamond, M. L., Hodge, E. (2007) Urban contaminant dynamics: from source to effect. *Environmental Science and Technology*, **41**(11): 3796–3800.
- Diamond, M. L., Melymuk, L. *et al.* (2009) Are PCBs legacy contaminants? (submitted).
- Diamond, M. L., Priemer, D. A., *et al.* (2001) Developing a multimedia model of chemical dynamics in an urban area. *Chemosphere*, **44**(7): 1655–1667.
- Dougherty, C. P., Holtz, S. H., *et al.* (2000) Dietary exposures to food contaminants across the United States. *Environmental Research*, **84**(2): 170–185.
- D’Silva, K., Fernandes, A., *et al.* (2006) Brominated organic micro-pollutants in the United Kingdom diet – results of the 2003 total diet study. *Organohalogen Compounds*, **68**: 770–773.
- Du, S., Belton, T. J., *et al.* (2008) Source apportionment of polychlorinated biphenyls in the tidal Delaware River. *Environmental Science and Technology*, **42**(11): 4044–4051.
- Fernie, K. J., Shutt, J. L., *et al.* (2008) Changes in reproductive courtship behaviors of adult American kestrels (*Falco sparverius*) exposed to environmentally relevant levels of the polybrominated diphenyl ether mixture, DE-71. *Toxicological Sciences*, **102**(1): 171–178.
- Fernie, K. J., Shutt, J. L., *et al.* (2009) Environmentally relevant concentrations of DE-71 and HBCD alter eggshell thickness and reproductive success of American kestrels. *Environmental Science and Technology*, **43**(6): 2124–2130.
- Fischer, D., Hooper, K., *et al.* (2006) Children show highest levels of polybrominated diphenyl ethers in a California family of four: A case study. *Environmental Health Perspectives*, **114**(10): 1581–1584.
- Gandhi, N., Bhavsar, S. P., *et al.* (2006) Development of a multichemical food web model: application to PBDEs in Lake Ellasjoen, Bear Island, Norway. *Environmental Science and Technology*, **40**(15): 4714–4721.
- Gasic, B., Moeckel, C., *et al.* (2009) Measuring and modeling short-term variability of PCBs in air and characterization of urban source strength in Zurich, Switzerland. *Environmental Science and Technology*, **43**(3): 769–776.
- Gauthier, L. T., Hebert, C. E., *et al.* (2008) Dramatic changes in the temporal trends of polybrominated diphenyl ethers (PBDEs) in herring gull eggs from the Laurentian Great Lakes: 1982–2006. *Environmental Science and Technology*, **42**(5): 1524–1530.
- Gewurtz, S. B., Diamond, M. L. (2003) Distribution and burdens of bioaccumulative contaminants in the Lake Erie food web: a review. *Environmental Reviews*, **11**(3): 141–160.
- Gewurtz, S. B., Gandhi, N., *et al.* (2005) A comparison of the mechanisms controlling PCB bioaccumulation in lakes of different latitudes: a modeling approach. *IAGLR Conference Program and Abstracts*, **48**: 63–64.
- Gingrich, S. E., Diamond, M. L. (2001) Atmospherically derived organic surface films along an urban-rural gradient. *Environmental Science and Technology*, **35**(20): 4031–4037.

- Gioia, R., Nizzetto, L., *et al.* (2008) Polychlorinated biphenyls (PCBs) in air and seawater of the Atlantic Ocean: sources, trends and processes. *Environmental Science and Technology*, **42**(5): 1416–1422.
- Hafner, W. D., Hites, R. A. (2005) Effects of wind and air trajectory directions on atmospheric concentrations of persistent organic pollutants near the Great Lakes. *Environmental Science and Technology*, **39**(20): 7817–7825.
- Hale, R. C., La Guardia, M. J., *et al.* (2002) Potential role of fire retardant-treated polyurethane foam as a source of brominated diphenyl ethers to the US environment. *Chemosphere*, **46**(5): 729–735.
- Harner, T., Shoeib, M., *et al.* (2006) Passive sampler derived air concentrations of PBDEs along an urban–rural transect: spatial and temporal trends. *Chemosphere*, **64**(2): 262–267.
- Harrad, S., Diamond, M. (2006) New directions: exposure to polybrominated diphenyl ethers (PBDEs) and polychlorinated biphenyls (PCBs): current and future scenarios. *Atmospheric Environment*, **40**(6): 1187–1188.
- Harrad, S., Hunter, S. (2006) Concentrations of polybrominated diphenyl ethers in air and soil on a rural-urban transect across a major UK conurbation. *Environmental Science and Technology*, **40**(15): 4548–4553.
- Harrad, S., Mao, H. J. (2004) Atmospheric PCBs and organochlorine pesticides in Birmingham, UK: concentrations, sources, temporal and seasonal trends. *Atmospheric Environment*, **38**(10): 1437–1445.
- Harrad, S., Wijesekera, R., *et al.* (2004) Preliminary assessment of UK human dietary and inhalation exposure to polybrominated diphenyl ethers. *Environmental Science and Technology*, **38**(8): 2345–2350.
- Harrad, S., Hazrati, S., *et al.* (2006) Concentrations of polychlorinated biphenyls in indoor air and polybrominated diphenyl ethers in indoor air and dust in Birmingham, United Kingdom: implications for human exposure. *Environmental Science and Technology*, **40**(15): 4633–4638.
- Harrad, S., Ibarra, C., *et al.* (2008a) Concentrations of brominated flame retardants in dust from United Kingdom cars, homes, and offices: causes of variability and implications for human exposure. *Environment International*, **34**(8): 1170–1175.
- Harrad, S., Ibarra, C., *et al.* (2008b) Polybrominated diphenyl ethers in domestic indoor dust from Canada, New Zealand, United Kingdom and United States. *Environment International*, **34**(2): 232–238.
- Harrad, S., Ibarra, C., *et al.* (2009) Polychlorinated biphenyls in indoor dust from Canada, New Zealand, United Kingdom and United States: implications for human exposure. *Chemosphere*, **76**(2): 232–238.
- Hazrati, S., Harrad, S. (2006) Causes of variability in concentrations of polychlorinated biphenyls and polybrominated diphenyl ethers in indoor air. *Environmental Science and Technology*, **40**(24): 7584–7589.
- Helm, P. A., Gewurtz, S. B., *et al.* (2008) Occurrence and biomagnification of polychlorinated naphthalenes and non- and mono-*ortho* PCBs in Lake Ontario sediment and biota. *Environmental Science and Technology*, **42**(4): 1024–1031.
- Herrick, R. F., McClean, M. D., *et al.* (2004) An unrecognized source of PCB contamination in schools and other buildings. *Environmental Health Perspectives*, **112**(10): 1051–1053.
- Hickey, J. P., Batterman, S. A., *et al.* (2006) Trends of chlorinated organic contaminants in Great Lakes trout and walleye from 1970 to 1998. *Archives of Environmental Contamination and Toxicology*, **50**(1): 97–110.
- Hites, R. A. (2004) Polybrominated diphenyl ethers in the environment and in people: a meta-analysis of concentrations. *Environmental Science and Technology*, **38**(4): 945–956.
- Hites, R. A., Foran, J. A., *et al.* (2004) Global assessment of organic contaminants in farmed salmon. *Science*, **303**(5655): 226–229.
- Hoff, R. M., Muir, D. C. G., *et al.* (1992) Annual cycle of polychlorinated biphenyls and organohalogen pesticides in air in southern Ontario. 2. Atmospheric transport and sources. *Environmental Science and Technology*, **26**(2): 276–283.
- Hoh, E., Hites, R. A. (2005) Brominated flame retardants in the atmosphere of the east-central United States. *Environmental Science and Technology*, **39**(20): 7794–7802.

- Hoh, E., Zhu, L. Y., *et al.* (2006) Dechlorane plus, a chlorinated flame retardant, in the Great Lakes. *Environmental Science and Technology*, **40**(4): 1184–1189.
- Huo, X., Peng, L., *et al.* (2007) Elevated blood lead levels of children in Guiyu, an electronic waste recycling town in China. *Environmental Health Perspectives*, **115**(7): 1113–1117.
- Ismail, N., Gewurtz, S. B., *et al.* (2009) Brominated and chlorinated flame retardants in Lake Ontario, Canada, lake trout (*Salvelinus namaycush*) between 1979 and 2004 and possible influences of food-web changes. *Environmental Toxicology and Chemistry*, **28**(5): 910–920.
- Jacobson, J. L., Jacobson, S. W. (1996) Intellectual impairment in children exposed to polychlorinated biphenyls *in utero*. *New England Journal of Medicine*, **335**(11): 783–789.
- Jamshidi, A., Hunter, S., *et al.* (2007) Concentrations and chiral signatures of polychlorinated biphenyls in outdoor and indoor air and soil in a major U.K. conurbation. *Environmental Science and Technology*, **41**(7): 2153–2158.
- Jaward, F. M., Farrar, N. J., *et al.* (2004) Passive air sampling of PCBs, PBDEs, and organochlorine pesticides across Europe. *Environmental Science and Technology*, **38**(1): 34–41.
- Jeremiason, J. D., Eisenreich, S. J., *et al.* (1998) PCB decline in settling particles and benthic recycling of PCBs and PAHs in Lake Superior. *Environmental Science and Technology*, **32**(21): 3249–3256.
- Johnson, B. L., Hicks, H. E., *et al.* (1998) Public health implications of persistent toxic substances in the Great Lakes and St. Lawrence basins. *Journal of Great Lakes Research*, **24**(3): 698–722.
- Jones, K. C., Sanders, G., *et al.* (1992) Evidence for a decline of PCBs and PAHs in rural vegetation and air in the United-Kingdom. *Nature*, **356**(6365): 137–140.
- Jones-Otazo, H. A., Clarke, J. P., *et al.* (2005) Is house dust the missing exposure pathway for PBDEs? An analysis of the urban fate and human exposure to PBDEs. *Environmental Science and Technology*, **39**(14): 5121–5130.
- Kelley, B., Ikonomou, M. G., *et al.* (2007) Food web-specific biomagnification of persistent organic pollutants. *Science*, **317**(236): 236–239.
- Kelly, B. C., Ikonomou, M. G., *et al.* (2008) Bioaccumulation behaviour of polybrominated diphenyl ethers (PBDEs) in a Canadian Arctic marine food web. *Science of the Total Environment*, **401**(1–3): 60–72.
- Kemmlin, S., Hahn, O., *et al.* (2003) Emissions of organophosphate and brominated flame retardants from selected consumer products and building materials. *Atmospheric Environment*, **37**(39–40): 5485–5493.
- Kennedy, C., Cuddihy, J., *et al.* (2007) The changing metabolism of cities. *Journal of Industrial Ecology*, **11**(2): 43–59.
- Kiviranta, H., Ovaskainen, M.-L., *et al.* (2004) Market basket study on dietary intake of PCDD/Fs, PCBs, and PBDEs in Finland. *Environment International*, **30**(7): 923–932.
- Kohler, M., Tremp, J., *et al.* (2005) Joint sealants: an overlooked diffuse source of polychlorinated biphenyls in buildings. *Environmental Science and Technology*, **39**(7): 1967–1973.
- Koizumi, A., Yoshinaga, T., *et al.* (2005) Assessment of human exposure to polychlorinated biphenyls and polybrominated diphenyl ethers in Japan using archived samples from the early 1980s and mid-1990s. *Environmental Research*, **99**(1): 31–39.
- Kolic, T. M., Shen, L., *et al.* (2009) The analysis of halogenated flame retardants by GC-HRMS in environmental samples. *Journal of Chromatographic Science*, **47**(1): 83–91.
- Kucklick, J. R., Harvey, H. R., *et al.* (1996) Organochlorine dynamics in the pelagic food web of Lake Baikal. *Environmental Toxicology and Chemistry*, **15**(8): 1388–1400.
- LaKind, J. S., Berlin, C. M. Jr., *et al.* (2008) Lifestyle and polybrominated diphenyl ethers in human milk in the United States: a pilot study. *Toxicological and Environmental Chemistry*, **90**(6): 1047–1054.
- Law, R. J., Allchin, C. R., *et al.* (2006) Levels and trends of brominated flame retardants in the European environment. *Chemosphere*, **64**(2): 187–208.
- Law, R. J., Bersuder, P., *et al.* (2008) A significant downturn in levels of hexabromocyclododecane in the blubber of harbor porpoises (*Phocoena phocoena*) stranded or bycaught in the UK: an update to 2006. *Environmental Science and Technology*, **42**(24): 9104–9109.
- Leung, A. O. W., Luksemburg, W. J., *et al.* (2007) Spatial distribution of polybrominated diphenyl ethers and polychlorinated dibenzo-*p*-dioxins and dibenzofurans in soil and combusted residue at

- Guiyu, an electronic waste recycling site in Southeast China. *Environmental Science and Technology*, **41**(8): 2730–2737.
- Ling, H., Diamond, M., Mackay, D. (1993) Application of the QWASI fugacity/equivalence model to assessing the fate of contaminants in the water and sediments of Hamilton Harbour. *Journal of Great Lakes Research*, **19**: 582–602.
- Lonky, E., Reihman, J., *et al.* (1996) Neonatal behavioral assessment scale performance in humans influenced by maternal consumption of environmentally contaminated Lake Ontario fish. *Journal of Great Lakes Research*, **22**(2): 198–212.
- Lorber, M. (2008) Exposure of Americans to polybrominated diphenyl ethers. *Journal of Exposure Science and Environmental Epidemiology*, **18**: 2–19.
- Mackay, D. (1989) Modeling the long-term behavior of an organic contaminant in a large lake – application to PCBs in Lake Ontario. *Journal of Great Lakes Research*, **15**(2): 283–297.
- Matos, G., Wagner, L. (1998) Consumption of materials in the United States, 1900–1995. *Annual Review of Energy and the Environment*, **23**: 107–122.
- Meijer, S. N., Ockenden, W. A., *et al.* (2003a) Spatial and temporal trends of POPs in Norwegian and UK background air: implications for global cycling. *Environmental Science and Technology*, **37**(3): 454–461.
- Meijer, S. N., Ockenden, W. A., *et al.* (2003b) Global distribution and budget of PCBs and HCB in background surface soils: implications for sources and environmental processes. *Environmental Science and Technology*, **37**(4): 667–672.
- Morf, L., Taverna, R., *et al.* (2003) *Selected polybrominated flame retardants PBDEs and TBBPA substance flow analysis*. Swiss Agency for the Environment, Forests and Landscape SAEFL, Berne.
- Morf, L. S., Tremp, J., *et al.* (2005) Brominated flame retardants in waste electrical and electronic equipment: substance flows in a recycling plant. *Environmental Science and Technology*, **39**(22): 8691–8699.
- Morf, L. S., Tremp, J., *et al.* (2007) Metals, non-metals and PCB in electrical and electronic waste; actual levels in Switzerland. *Waste Management*, **27**(10): 1306–1316.
- Motelay-Massei, A., Harner, T., *et al.* (2005) Using passive air samplers to assess urban–rural trends for persistent organic pollutants and polycyclic aromatic hydrocarbons. 2. Seasonal trends for PAHs, PCBs, and organochlorine pesticides. *Environmental Science and Technology*, **39**(15): 5763–5773.
- Nnorom, I. C., Osibanjo, O. (2008) Sound management of brominated flame retarded (BFR) plastics from electronic wastes: state of the art and options in Nigeria. *Resources Conservation and Recycling*, **52** 1362–1372.
- Norstrom, R. J., Simon, M., *et al.* (1988) Organochlorine contaminants in arctic marine food chains: identification, geographical distribution and temporal trends in polar bears. *Environmental Science and Technology*, **22**(9): 1063–1071.
- Ockenden, W. A., Breivik, K., *et al.* (2003) The global re-cycling of persistent organic pollutants is strongly retarded by soils. *Environmental Pollution*, **121**(1): 75–80.
- OECD (2001) *Environmental Outlook for the Chemicals Industry*. Paris.
- Offenberg, J. H., Baker, J. E. (1997) Polychlorinated biphenyls in Chicago precipitation: enhanced wet deposition to near-shore Lake Michigan. *Environmental Science and Technology*, **31**(5): 1534–1538.
- Ohta, S., Ishizuka, D., *et al.* (2002) Comparison of polybrominated diphenyl ethers in fish, vegetables, and meats and levels in human milk of nursing women in Japan. *Chemosphere*, **46** (5): 689–696.
- Palm, A. (2001) The environmental fate of polybrominated diphenyl ethers in the centre of Stockholm – assessment using a multimedia fugacity model. Swedish Environmental Research Institute Ltd, IVL Rapport/report B 1400, M.S.
- Petreas, M., Oros, D. (2009) Polybrominated diphenyl ethers in California wastestreams. *Chemosphere*, **74**(7): 996–1001.
- Pham, T.-T., Proulx, S. (2007) PCBs and PAHs in the Montreal urban community (Quebec, Canada) waterwater treatment plant and in the effluent plume in the St. Lawrence River *Water Research*, **31**: 1887–1896.

- Pozo, K., Harner, T., *et al.* (2006) Toward a global network for persistent organic pollutants in Air: results from the GAPS Study. *Environmental Science and Technology*, **40**(16): 4867–4873.
- Priemer, D. A., Diamond, M. L. (2002) Application of the multimedia urban model to compare the fate of SOCs in an urban and forested watershed. *Environmental Science and Technology*, **36**(5): 1004–1013.
- Qu, W. Y., Bi, X. H., *et al.* (2007) Exposure to polybrominated diphenyl ethers among workers at an electronic waste dismantling region in Guangdong, China. *Environment International*, **33**: 1029–1034.
- Robson, M., Harrad, S. (2004) Chiral PCB signatures in air and soil: implications for atmospheric source apportionment. *Environmental Science and Technology*, **38**(6): 1662–1666.
- Robson, M., Melymuk, L., *et al.* (2008) Comparison of concentrations and loadings of PCBs and PAHs in urban and rural streams during base flow and storm events. *Organohalogen Compounds*, **70**: 685–688.
- Robson, M., Melymuk, L., *et al.* (2009) Continuing sources of PCBs: the significance of building sealants (submitted).
- Ross, P. S., Couillard, C. M., *et al.* (2009) Large and growing environmental reservoirs of deca-BDE present an emerging health risk for fish and marine mammals. *Marine Pollution Bulletin*, **58**(1): 7–10.
- Rudel, R. A., Perovich, L. J. (2009) Endocrine disrupting chemicals in indoor and outdoor air. *Atmospheric Environment*, **43**(1): 170–181.
- Rudel, R. A., Seryak, L. M., *et al.* (2008) PCB-containing wood floor finish is a likely source of elevated PCBs in residents' blood, household air and dust: a case study of exposure. *Environmental Health*, **7**(2), DOI: 10.1186/1476-069X-7-2.
- Ryan, J. J. (2004) Polybrominated diphenyl ethers (PBDEs) in human milk; occurrence worldwide. In *Third International Workshop on Brominated Flame Retardants*, Toronto, Ontario, Canada, pp. 17–21.
- Sanders, G., Jones, K. C., *et al.* (1992) Historical inputs of polychlorinated biphenyls and other organochlorines to a dated lacustrine sediment core in rural England. *Environmental Science and Technology*, **26**(9): 1815–1821.
- Schaeffer, D. J., Dellinger, J. A., *et al.* (2006) Serum PCB profiles in Native Americans from Wisconsin based on region, diet, age, and gender: implications for epidemiology studies. *Science of the Total Environment*, **357**(1–3): 74–87.
- Schecter, A. J., Piskac, A. L. (2001) PCBs, dioxins, and dibenzofurans: measured levels and toxic equivalents in blood, milk and food from various countries. *PCBs: Recent Advances in Environmental Toxicology and Health Effects*, **2001**: 161–168.
- Schecter, A., Harris, T. R., *et al.* (2008) Brominated flame retardants in US food. *Molecular Nutrition and Food Research*, **52**(2): 266–272.
- Schenker, U., Soltermann, F., *et al.* (2008) Modeling the environmental fate of polybrominated diphenyl ethers (PBDEs): the importance of photolysis for the formation of lighter PBDEs. *Environmental Science and Technology*, **42**(24): 9244–9249.
- Schlummer, M., Maurer, A., *et al.* (2006) Report: recycling of flame-retarded plastics from waste electric and electronic equipment (WEEE). *Waste Management and Research*, **24**(6): 573–583.
- Schmidt, C. W. (2006) Unfair trade – e-waste in Africa. *Environmental Health Perspectives*, **114**(4): A232–A235.
- Shaw, S. D., Berger, M. L., *et al.* (2009) Bioaccumulation of polybrominated diphenyl ethers and hexabromocyclododecane in the northwest Atlantic marine food web. *Science of the Total Environment*, **407**(10): 3323–3329.
- Shen, L., Wania, F., *et al.* (2006) Polychlorinated biphenyls and polybrominated diphenyl ethers in the North American atmosphere. *Environmental Pollution*, **144**(2): 434–444.
- Shoeb, M., Harner, T., *et al.* (2004) Indoor and outdoor air concentrations and phase partitioning of perfluoroalkyl sulfonamides and polybrominated diphenyl ethers. *Environmental Science and Technology*, **38**(5): 1313–1320.

- Simcik, M. F., Zhang, H., *et al.* (1997) Urban contamination of the Chicago/Coastal Lake Michigan atmosphere by PCBs and PAHs during AEOLOS. *Environmental Science and Technology*, **31**(7): 2141–2147.
- Stapleton, H. M., Letcher, R. J., *et al.* (2004) Dietary accumulation and metabolism of polybrominated diphenyl ethers by juvenile carp (*Cyprinus carpio*). *Environmental Toxicology and Chemistry*, **23**(8): 1939–1946.
- Stapleton, H. M., Dodder, N. G., *et al.* (2005) Polybrominated diphenyl ethers in house dust and clothes dryer lint. *Environmental Science and Technology*, **39**(4): 925–931.
- Stapleton, H. M., Brazil, B., *et al.* (2006) *In vivo* and *in vitro* debromination of decabromodiphenyl ether (BDE 209) by juvenile rainbow trout and common carp. *Environmental Science and Technology*, **40**(15): 4653–4658.
- Stapleton, H. M., Allen, J. G., *et al.* (2008) Alternate and new brominated flame retardants detected in U.S. house dust. *Environmental Science and Technology*, **42**(18): 6910–6916.
- Szinder-Richert, J., Barska, I., *et al.* (2009) PCBs in fish from the southern Baltic Sea: levels, bioaccumulation features, and temporal trends during the period from 1997 to 2006. *Marine Pollution Bulletin*, **58**(1): 85–92.
- Thomsen, C., Liane, V., *et al.* (2005) Levels of brominated flame retardants in human samples from Norway through three decades. *Organohalogen Compounds*, **67**: 658–661.
- Totten, L. A., Stenichikov, G., *et al.* (2006) Measurement and modeling of urban atmospheric PCB concentrations on a small (8 km) spatial scale. *Atmospheric Environment*, **40**(40): 7940–7952.
- Van Gerven, T., Geysen, D., *et al.* (2004) Estimation of the contribution of a municipal waste incinerator to the overall emission and human intake of PCBs in Wilrijk, Flanders. *Chemosphere*, **54**(9): 1303–1308.
- Van Oostdam, J., Donaldson, S. G., *et al.* (2005) Human health implications of environmental contaminants in Arctic Canada: a review. *Science of the Total Environment*, **351**: 165–246.
- Venier, M., Hites, R. A. (2008) Flame retardants in the atmosphere near the Great Lakes. *Environmental Science and Technology*, **42**(13): 4745–4751.
- Verboven, N., Verreault, J., *et al.* (2009) Nest temperature and parental behaviour of Arctic-breeding glaucous gulls exposed to persistent organic pollutants. *Animal Behaviour*, **77**(2): 411–418.
- Voldner, E. C., Smith, L., *et al.* (1986) Production, usage and atmospheric emissions of 15 priority toxic chemicals. W.Q.B. Great Lakes Science Advisory Board, International Air Quality Advisory Board, International Joint Commission.
- Wan, Y., Hu, J., *et al.* (2008) Trophodynamics of polybrominated diphenyl ethers in the marine food web of Bohai Bay, North China. *Environmental Science and Technology*, **42**(4): 1078–1083.
- Wania, F., Dugani, C. B. (2003) Assessing the long-range transport potential of polybrominated diphenyl ethers: a comparison of four multimedia models. *Environmental Toxicology and Chemistry*, **22**(6): 1252–1261.
- Watanabe, I., Yakushiji, T., *et al.* (1979) Surveillance of the daily PCB intake from diet of Japanese women from 1972 through 1976. *Archives of Environmental Contamination and Toxicology*, **8**(1): 67–75.
- Webster, T. F., Harrad, S., *et al.* (2009) Identifying transfer mechanisms and sources of decabromodiphenyl ether (BDE 209) in indoor environments using environmental forensic microscopy. *Environmental Science and Technology*, **43**(9): 3067–3072.
- Weschler, C. J. (2009) Changes in indoor pollutants since the 1950s. *Atmospheric Environment*, **43**: 153–169.
- Weschler, C. J., Nazaroff, W. W. (2008) Semivolatile organic compounds in indoor environments. *Atmospheric Environment*, **42**(40): 9018–9040.
- Wilford, B. H., Harner, T., *et al.* (2004) Passive sampling survey of polybrominated diphenyl ether flame retardants in indoor and outdoor air in Ottawa, Canada: implications for sources and exposure. *Environmental Science and Technology*, **38**(20): 5312–5318.
- Wilson, N. K., Chuang, J. C., *et al.* (2003) Aggregate exposures of nine preschool children to persistent organic pollutants at day care and at home. *Journal of Exposure Analysis and Environmental Epidemiology*, **13**(3): 187–202.

- Wong, F., Robson, M., *et al.* (2009) Concentrations and chiral signatures of POPs in soils and sediments: a comparative urban versus rural study in Canada and UK. *Chemosphere*, **74**(3): 404–411.
- Wu, N., Herrmann, T., *et al.* (2007) Human exposure to PBDEs: associations of PBDE body burdens with food consumption and house dust concentrations. *Environmental Science and Technology*, **41** (5): 1584–1589.
- Wu, J. P., Luo, X. J., *et al.* (2008) Bioaccumulation of polybrominated diphenyl ethers (PBDEs) and polychlorinated biphenyls (PCBs) in wild aquatic species from an electronic waste (e-waste) recycling site in South China. *Environment International*, **34**(8): 1109–1113.
- Wu, J.-P., Luo, X.-J., *et al.* (2009) Biomagnification of polybrominated diphenyl ethers (PBDEs) and polychlorinated biphenyls in a highly contaminated freshwater food web from South China. *Environmental Pollution*, **157**(3): 904–909.
- Zhang, X., Diamond, M. L., *et al.* (2009) Multimedia modeling of PBDE emissions and fate indoors. *Environmental Science and Technology*, **43**(8): 2845–2850.
- Zhang, X., Robson, M., *et al.* (in prep) Polybrominated diphenyl ethers (PBDEs) and polychlorinated biphenyls in the indoor environment of Toronto, Canada.
- Zota, A. R., Rudel, R. A., *et al.* (2008) Elevated house dust and serum concentrations of PBDEs in California: unintended consequences of furniture flammability standards? *Environmental Science and Technology*, **42**(21): 8158–8164.

Index

Page numbers in *italics* refer to figures; page numbers in **bold** refer to tables.

- activated sludge 85–6, 91
- Agent Orange 142
- air *see* atmosphere; indoor air
- Arctic ecosystem
 - biomagnification of PFCs 39
 - food webs 100, 103–4, 105
 - levels of BFRs 11, 15
 - POPs in Polynya invertebrates 94
 - sources of PFCs 50, 51
- atmosphere
 - see also* indoor air; volatilization
 - air-surface exchange 85, 111–16, 175, 185, 189
 - downwind contamination, from cities 190, 191, 246–7, 258
 - long-range POP transport 11, 15, 50–1, 185
 - observed BFR concentrations **218–19**
 - observed PFC concentrations 51–2, **222**
 - rural and urban contamination **177, 179–82**, 185–6, 247–8
 - sampling and analysis 41, 42, 148–50
- BDEs *see* polybrominated diphenyl ethers (PBDEs)
- bioaccumulation
 - food chain/web magnification 13, 39, 244, 249–50
 - and metabolic debromination (PDBEs) 258
 - in human milk 12–13, 13, 109, 155, 258
 - from plants 92
 - potential estimation, by lipophilicity 10–11, **11**
 - in wildlife 14–15, 38–9, 56–8, 100, 101
- biotransformation 73, 258
 - by macroorganisms
 - aquatic mammals 100–5
 - birds and eggs 98–100
 - fish 38, 95–8
 - invertebrates 94–5
 - plants 91–2
 - terrestrial mammals 105–9
 - microbial
 - in natural waters 83–5
 - in soils and sediments 86–91, 92–3, 111, 191
 - in wastewater/activated sludge 85–6
 - rate determination 109–11
- birds
 - detoxification of POPs 98–9
 - POP residue composition in eggs 57, 58, 99–100
- bivalves
 - biotransformation abilities 94–5
 - Mussel Watch programmes (POP monitoring) 154–5, **157**
- breast milk
 - bioaccumulation of POPs 12–13, 13, 109, 155
 - geographical analysis of POPs **158**, 158–9, 258–9
- brominated flame retardants (BFRs)
 - see also* hexabromocyclododecane (HBCD/HBCDD); polybrominated diphenyl ethers (PBDEs); tetrabromobisphenol-A (TBBP-A)
 - bioaccumulation 10–11, **11**, 12–15, 103, 258
 - chirality 78–9, 80

- brominated flame retardants (BFRs) (*Continued*)
- contamination
 - air **218–19**
 - indoor dust **220–1**, 259
 - emission mechanisms 216
 - human intake 15–17, **224–5**, 258–60
 - measurement and analysis 8–10, 9, 215
 - pollutant sources 7, 15, 215–17, 230–1
 - production and demand 5, **6**, 254–7, 256
 - regulation of 5–7, 12–13, 260–1
 - toxicity 12, 17, 260
 - types and applications 5, 10, **215**, 254
 - method of product incorporation 212–13
 - building materials, emissions 174, 213–14, 232–3, 245, 249
 - butter, for POP assessment **150**, 150–1
- carcinogenic activity 12, 32
- cetaceans (porpoises/whales), POP metabolism capacity 103–5
- chemical interactions, in urban environment 188–91, 197
- chirality
 - composition reporting metrics (ER/EF) 81–2
 - effect on toxicity 72
 - enantioselective measurement 72, 79–81
 - extent, in POPs 71
 - for identifying pollutant source 111–16
 - in measurement of biotransformation 109–11, 117–18
- chlordanes 73–4
 - environmental contamination 86–7, 87, 148, **177**, **178**
 - in seal tissues 100–1
 - soil persistence, variability 92, 92–3
 - stereoisomer structures 76
 - uptake by plants 91–2
- Clausius-Clapeyron equation 186
- combustion emissions
 - landfill and urban open fires 143, 145, 175
 - residential heating 174
 - vehicle fuel 174, 194
- consumer products, as emissions source 174–5, 215–17, 245, 254–7
- cytochrome P450 (CYP) activity, in biotransformation 97, 103, 106, 107
- debromination to toxic congeners 18, 260
- determination and analysis 8
- dust contamination mechanisms 216
- molecular structure 6
- degradation of POPs 11, 83, 116–17, 188–91, 213
 - see also* biotransformation
- developing countries
 - continuing emission of legacy POPs 138
 - data on environmental contamination 147–8, 161
 - industrialization 138, 173
- POP problems (compared to developed countries)
 - effective regulation 160
 - financial and technical constraints 159–60
 - information and understanding 160–1
 - stockpiled pesticides 139–40, 160
 - working standards, environmental 145, 258
- dichlorodiphenyltrichloroethane (DDT)
 - chemical structure 74
 - continuing use
 - detected by mussel monitoring 155
 - for public health 139, 148
 - environmental contamination **177**, **182**
 - persistence in soils and sediments 88, 112, 113, 154
- dietary intake
 - of BFRs, from fish/shellfish 15–16, 259
 - estimates of PFCs 227
 - from food processing/packaging 48–9, 259–60
 - rate of decline, after POP ban 250–3
- dioxins/furans (PCDD/Fs) 141–2
 - from vehicles 174, 194
 - from waste combustion 145, 159, 175, 176
- dumping, illegal 141, 146
- dust, indoor
 - BFR contamination 7, **220–1**, 259
 - dust loading and dilution 227–8, 229
 - human exposure **224–5**, 226
 - disposal pathways 244
 - microspatial variation 231, 232–3, **233**
 - PCB contamination **214**, 214–15, 226
 - PFC contamination **223**, 226–7
 - sampling methods 210–12
- education, for POP obligations 160–1
- eggs, as biomonitoring tool 99–100
- decabromodiphenyl ether (BDE-209)
 - atmospheric transport 11, 15

- electrochemical fluorination
 (ECF process) 28–9, 50
- electronic equipment
 BFR emissions during use 215–16
 e-waste (WEEE), as source of BFR
 pollution 7, 144–5, 146–7, 254–5, 258
 production rate 246, 254
- emissions
 from additive and reactive products 212–13
 mechanisms of BFR release 216
 point and diffuse sources 173, 228–31
 rate studies, for risk assessment 197
 urban sources 173–5, 189, 192, 246–7
- enantiomer ratio/fraction (ER/EF) 81–2
 used for pollutant source signatures 111, 186–7
- endocrinal effects
 of PDBEs 12, 17
 of PFCs 32
- endosulfan, geographical distribution 148
- environmental contamination
see also bioaccumulation; persistence
 accidental spillage 39, 49–50, 53
 aquatic sediment records 13–14, 55–6, 86–91, 151
 biochemical weathering 73, 82, 93, 109–11
 data comparison problems 147–8
 long-range transport 11, 15, 50–1, 185
 monitoring long-term POP removal 15, 118
 near municipal dumpsites 145–6, **146**
 in oceans, variation with depth 85
 remediation 197–8
 sources of BFRs 7, 15
 sources of PFCs 49–51
 transfer from indoor sources 243–4
 urban areas 172–5, 185–7, 189, 191–3, 192
- fish
 biotransformation capability 95–8
 as dietary BFR source 15–16, 259
 as dietary PCB source 253
 health, and POP contamination 191, 193
- fluorinated polymers, structure 28
- fluorine
 atomic and bonding properties 33–4
 measurement, total organic 46
- fluorotelomer alcohols (FTOHs)
 analysis 44–5, 55
 bioaccumulation and persistence 38, 40, 41, 50–1
- environmental sources and levels 49–50, 57
 atmosphere 51–2
 production 30
 properties 34, **35–6**, 37, 38, 39
 structure 25, 27
 toxicity 32
- fluorotelomer carboxylic acids (/carboxylates) (FTCAs)
 analysis 42, **43**, 45
 environmental presence 38, 52–3, 55, 57
 structure 27–8
 toxicity 33
 unsaturated (FTUCAs) 27–8
- fluorotelomer sulfonic acids (/sulfonates) (FTSs)
 analysis 42, **44**, 47
 environmental contamination 53
 structure 28
- forensics, detection of illegal chemical use 91
- furans *see* dioxins/furans (PCDD/Fs)
- GC-MS analysis
 for measurement of BFRs 8–9
 for volatile PFC measurement 44–5
- Global Atmospheric Passive Samplers (GAPS)
 study 148–50, 149, 150
- health quality, in urban areas 196
- hepatic metabolism, effects of PFCs 31–2
- heptachlor epoxide 74, 76
- hexabromocyclododecane (HBCD/HBCDD)
 additive product incorporation 212–13
 determination and analysis 9–10, 117
 environmental persistence 11, 86, 114, 213
 metabolism, in higher organisms 98, 100, 104–5
 molecular structures 6, 79, 80
- hexachlorobenzene (HCB) 142–3
- hexachlorocyclohexane (HCH)
 α -HCH
 atmospheric sources 85, 115–16, 148
 bioaccumulation, in seals 101, 102
 enantioselective blood-brain transfer 98, 101, 106
 microbial degradation 83–5, 86
 γ -HCH (lindane) 73, 139, 148
 soil concentrations 154
 structures, chirality 75
 technical, isomeric composition 73
- household dust *see* dust, indoor

- household goods, as emissions source 174–5, 215–17, 245, 254–7
- human exposure
- chiral POP measurements 108–9
 - geographical variation 13, 16, 226, 231–2
 - indoor, spatial and temporal variation 217, 228–31, 244–5
 - near municipal dumpsites 145–6
 - pathways 244–5, 245, 259–60
 - dietary 15–16, 48–9, 227, **227**, 250–3
 - food web incorporation 191, 244–5
 - indoor dust ingestion **224–5**, 226, 227–8, 258–9
 - inhalation 16, 226, **227**, 228
 - POP bioavailability 49, 217
 - vulnerable groups
 - children 7, 17, 158, 226, 227
 - manufacturing workers 7, 47–8
- incineration, waste, as POP source 141, 142, 143, 175
- indoor air
- BFR contamination 7, **218–19**, 257
 - office sources 216, 232–3
 - emissions sources 174–5, 186–7
 - sampling methods 210, **210**, 228
 - variation between rooms 231
- infrastructure, transport 173, 194
- invertebrates, aquatic, biotransformation of POPs 94–5
- landfill sites
- open combustion products 143, 145, 175
 - POP levels in local populations 145–6, 159
- LC-MS analysis
- for measurement of HBCD and TBBP-A 10
 - for PFC measurement 42–4, **43–4**
- legacy POPs, ongoing use in developing countries 138
- legislative framework for POP control 5, 160
- Lindane *see* hexachlorocyclohexane (HCH)
- mammals, POP degradation capability
- marine
 - cetaceans (porpoises/whales) 103–5
 - pinnipeds (seals/walruses) 100–3
 - terrestrial
 - Arctic species 105–6
 - humans 108–9
 - rodents 106–8
- measurement techniques
- analytical quality control 10, 46–7, 81
 - background contamination 40
 - enantioselective analysis 72, 79–82, 117
 - mass spectrometry applications 8–10, 42–5
 - nuclear magnetic resonance (NMR) 46
 - sampling and extraction 8, 41–2, 148, 210–12, 228
 - specificity 215
- methylsulfonyl PCBs, in mammals 102–3, 104, 107
- microbial degradation *see* biotransformation
- milk, human *see* breast milk
- multimedia urban model (MUM) 176, 188–91, 189
- musks, polycyclic 77–8
- biotransformation by fish species 97
 - chemical structures 79
 - environmental contamination (air) **181**
 - in wastewater/sludge 86
- neurotoxic activity 12, 17
- organochlorine (OC) pesticides
- detoxification
 - by fish species 95–7
 - by rodents 106
 - levels in air 148–9
 - persistence in soils 91–3, 111–13, 114–15
 - stockpiles, in developing countries 139–40
 - types and history of uses 73–4, 139
- partitioning
- coefficients, of PFCs **35**, **36**, 37–8, 39–40
 - indoor air and dust 213, 214
 - surface adsorption **35**, 38
- perfluorinated chemicals (PFCs)
- bioaccumulation **36**, 38–9
 - comparison with hydrocarbons 33–4
 - environmental levels 51–8, 217
 - indoor and outdoor air **222**
 - indoor dust **223**, 226–7
 - manufacturing processes 28–30
 - physical and chemical properties 33–8, **35–6**, 39–40
 - production and regulation history 29, 30–1
 - sampling and measurement 40–7
 - sources of contamination 48–51
 - toxicity 31–3
 - types and applications 25–8, **26**, 143, 171

- perfluoroalkyl compounds *see* perfluorinated chemicals (PFCs)
- perfluoroalkylsulfonic acids (/sulfonates) (PFSAs)
see also perfluorooctane sulfonate (PFOS)
 bioaccumulation 39, 47, 48, 49, 56–7
 environmental presence and persistence 38, 40, 50–1, 52, 56
 water contamination 38, 53–5
 extraction and analysis 41, 42, **43**, 45, 47
 production 29, 30–1
 properties 34, **35–6**, 36–7, 38, 44
 structure 27
 toxicity 31–2
- perfluorocarboxylic acids (/carboxylates) (PFCAs)
see also perfluorooctane carboxylic acid (PFOA)
 analysis 41, 42, **43**, 45, 46
 bioaccumulation 39, 47, 48, 49, 56–7
 environmental presence
 persistence 40, 57–8
 water contamination 38, 53–5
 production 29, 30, 31
 properties 34, **35–6**, 36–7
 structure 27
 toxicity 31–2, 33
- perfluorooctane carboxylic acid (PFOA)
 environmental presence 50, 51, 52, 53–5
 human exposure 47, 48, 49
 production 29, 30, 31
 properties 34, 36, 37, 38
 structure 27
 toxicity 31–2
- perfluorooctane sulfonate (PFOS)
 analysis 44, 45, 47
 bioaccumulation 39, 47–8, 49, 56, 57–8
 environmental presence 40, 51, 52, 53–5, 143
 production 29, 30–1
 properties 36, 37
 structure 27
 toxicity 31–2
- persistence
 in body tissues (PFCs) 31–2
 environmental reservoirs of POPs 242, 262
 environmental stability (PFCs) 40, 50
 monitoring, using enantiomers 110, 113–16
- Persistent Organic Pollutants Review Committee (POPRC) 1–2
- pesticides, urban use 174
- photolysis 18, 83, 116–17, 213
- plants *see* vegetation
- polyaromatic hydrocarbons (PAHs) 138
 environmental contamination 171, **178**, **180**
 urban degradative loss 188–91, 190
- polybrominated diphenyl ethers (PBDEs)
 commercial formulations 6, 8, 14, 144
 contamination pathways 18, 144–5, 192
 decabromodiphenyl ether (BDE-209) 11, 15, 18, 216
 human intake 226, 228, 258–60
 indoor emissions sources 216–17
 regulation and contamination trends 5–6, 12–15, 149–50, 255, 260–1
- polychlorinated biphenyls (PCBs)
 biotransformation, macrobiotic 96, 97, 99, 101–4, 106–7
 chirality 74, 76, 77
 congener/metabolite stability 74–6, 107–8
 contamination
 environmental levels and pathways **178**, **179–80**, 192, 249–50
 following production ban 250–4
 indoor and outdoor air 213–14, **214**
 indoor dust **214**, 214–15
 human intake 226, **227**, 250–3
 microbial degradation 88–9, 90, 93
 enantiomer preference of bacterial strains 89–91
 sources, pollutant
 atmospheric 113–14, **177**, 186–7, 249
 in developing countries 141, 145, 149
 types and history of uses 74, 140, 171, 248–9
 indoor 213, 213–14
- polychlorinated dibenzo-*p*-dioxins *see* dioxins/
 furans (PCDD/Fs)
- polychlorinated dibenzofurans *see* dioxins/
 furans (PCDD/Fs)
- polychlorinated naphthalenes (PCNs)
 143–4, 171
- polyfluorinated sulfonamides (FSAs)
 analysis 44–5
 bioaccumulation 38, 57
 environmental presence 40, 48, 49–50
 atmospheric 51–2
 production 29
 properties 34, **35–6**, 37, 39
 structure 25
 toxicity 32

- population density (human) 172, 173, 193, 197, 246
- pyrethroids 77, 78
 abiotic isomerization 116–17
 in rat tissues 108
 toxicity and microbial biotransformation 93
- quality control, analytical 81
 BFR analysis 10
 PFC analysis 46–7
- reference materials, analytical 10, 46–7, 81
- regulation
 effectiveness 241–2, 245, 253–4, 260–1
 global variation 261–2
 information on chirality 72–3
 legislation 5, 160
 risk assessments 5–6, 197
- residential development
 effects of density/sprawl
 energy use and output 195
 traffic emissions/VKT 193–4
 over localized contamination hotspots 196
- rodents, detoxification of POPs 106–8
- rural contamination, compared with
 urban 172, 176, **177–8**
 observed concentrations **179–84**
- sampling
 air, active and passive methods 148, 210, **210**, 228
 indoor dust 210–12
- seals, bioprocessing of POPs 100–3
- sediments, aquatic
 BFR contamination 13–14
 microbial POP degradation 86–91
 OC pesticides, regional variation 151, **152**
 PFC contamination 55–6
 urban and rural contamination **183**
- shellfish, dietary source of POPs 15, 16
see also bivalves
- soils
 geographical POP variation **153**, 154, **183–4**
 global survey of PCBs 140
 microbial degradation of legacy POPs 91–3
 OC pesticide volatilization, to air 111–13
 PFC sorption 38
 as POP sinks 151
 urban and rural contamination **178**, **183–4**, 186, 191
- solid-phase extraction (SPE) methods 41–2
- solubility, aqueous, of PFCs 34, **35**, 36–7
- source identification, pollutant 111–16, 185–7, 215–16
- Stockholm Convention
 listed chemicals 1–2, **2**, 137–8
 ratification and objectives 1, 253–4
- stormwater
 management 195–6
 runoff contamination 185, 187–8, 189, 192–3
- surface film contamination, urban **178**, **182–3**, 187, 188–91, 249
- telomerization 29–30
- temperature
 and surface volatilization 186, 216
 urban heat islands 195
- tetrabromobisphenol-A (TBBP-A)
 determination and analysis 10
 molecular structure 6
 reactive product incorporation 212–13
- toxaphene
 chemical structure 74
 microbial degradation 87–8
 in seal tissues 101
- toxicology
 bioactivity of BFRs 12, 17
 bioactivity of PFCs 31–3
 differential, among enantiomers 72
 toxicokinetic mechanisms 105, 106–7, 108, 118–19
- United Nations Environment Programme (UNEP) 1, 145, 156
- urban environment
see also residential development
 conceptual models of POP
 distributions 176, 189, 242–4, 243
 contamination gradients
 urban/rural 172, 176, **177–8**, 247–8
 vertical 185
 efficiencies and benefits of population
 density 172, 197
 emissions
 dynamic transfer and fate of POPs 190, 192, 243–4, 257–8
 economic/demographic effects 173, 197
 sources 173–5, 185–7, 257–8
 observed POP concentrations **179–84**

- as POP reservoir 234, 246, 249
 - warming ('heat islands') 191, 195
- vegetation
- enantiospecific tissue uptake 91–2
 - radiant heat from, in suburbs 195
 - urban and rural contamination **178, 183**
- vehicles
- diesel freight transport 194
 - fuel combustion products 174
 - in-car emissions 174, **232, 233**, 233–4
 - vehicle kilometres travelled (VKT) 173, 193–4
- volatilization
- effect of climate 141
- seasonal variation 189, 229–30
- temperature dependence 186, 195, 216
- waste, hazardous
- see also* electronic equipment
 - illegal dumping 141, 146
 - at landfill sites 145–6, 159, 175, 244
 - sustainable disposal initiatives 261
- water
- see also* stormwater
 - dynamic α -HCH exchange with air 115–16
 - evidence of microbial POP degradation 83–5
 - observed PFC contamination 52–5
 - sampling and analysis 41, 42
 - solubility of PFCs in 34, **35**, 36–7
 - wastewater treatment 86, 175, 191, 195, 244